

Tra il mare e la sabbia, (ed.), program AMELA, Paris ?

D. VAN DALEN

"The War of the Frogs and the Mice", *The Mathematical Intelligencer*, to appear.

"Pisa Lecture", Pisa 1989.

G. VERONESE

Fondamenti di Geometria, Tipografia del Seminario, Padova 1891.

H. WEYL

Das Kontinuum, de Gruyter, Leipzig 1918; repr. 1932; italian translation *Il Continuo*, A.B. Veit Riccioli (ed.), Bibliopolis, Napoli 1977.

"Eine Erinnerung an Hermann Weyl", with G. Pólya, *Math. Zeits.*, **126** (1972), 296-298.

"Reine Infinitesimalgeometrie", *Math. Zeits.*, **2** (1918), 384-411; repr. in *Gesammelte Abhandlungen II*, K. Chandrasekharan (ed.), Springer V. Berlin 1968, 1-28.

"Über die neue Grundlagenkrise der Mathematik", *Math. Zeits.*, **10** (1921), 39-79; repr. in *Gesammelte Abhandlungen II*, 143-180.

"Comments on Hilbert's second lecture on the foundations of mathematics", in *From Frege to Gödel*, J. van Heijenoort (ed.), Harvard University Press, Cambridge 1967, 480-484.

"Axiomatic Versus Constructive Procedures in Mathematics", T. Tonietti (ed.), *The Mathematical Intelligencer*, **7**, n.4 (1985), 10-17 and 38.



EVIDENCE FOR WEBER-WESLEY ELECTRODYNAMICS

J. P. Wesley

Weiherdammstrasse 24

7712 Blumberg, West Germany

Abstract

Weber-Wesley electrodynamics predicts all of the usual results of the Maxwell theory including electromagnetic radiation. It also predicts results where the Maxwell theory fails or is not applicable: 1) the force on Ampere's bridge in agreement with the measurements of Moysides and Pappas, 2) the tension required to rupture current carrying wires as observed by Graneau, 3) the force to drive the Graneau-Hering submarine, 4) the force to drive the mercury in Hering's pump, 5) the zero self-torque observed by Pappas and Vaughan on a Z-shaped antenna, 6) the localized unipolar induction observed by Kennard and Müller, 7) the result of Kaufmann's measurement of e/m without mass change with velocity, 8) a nonradiating hydrogen atom, and 9) the fine-structure splitting of hydrogen-atom energy levels without mass change with velocity. It is concluded that there is, thus, no evidence supporting mass change with velocity. Experiments are suggested.

1. WEBER-WESLEY ELECTRODYNAMICS

Weber⁽¹⁾ wrote his original theory in 1848 to fit the then known facts: Coulomb's law, Ampere's original empirical law for the force between current elements, and Faraday's law of electromagnetic induction. Weber introduced the idea that electric current was composed of flowing charges, where each charge was quantized to fit Faraday's law of electrochemical deposition ($e = Q/N_0$ where Q is the net charge to deposit a gram atomic equivalent and N_0 is Avogadro's number). Weber postulated a velocity dependent potential between two moving charges, q at \mathbf{r} and q' at \mathbf{r}' , as

$$U = (qq'/R) \left[1 - (dR/dt)^2 / 2c^2 \right], \quad (1)$$

where $R = |\mathbf{r} - \mathbf{r}'|$ and the constant c was assumed to be the velocity of light. The first term on the right of Eq. (1) is simply the Coulomb potential. Following a suggestion by Phipps⁽²⁾ to correct an objection by Helmholtz⁽³⁾ that Eq. (1) predicts a "negative" mass when a particle moves with a velocity greater than $\sqrt{2}c$, the Weber potential, Eq. (1), may be written as

$$U = (qq'/R)\sqrt{1 - (dR/dt)^2/c^2}. \quad (2)$$

This generates all of the observed results for small velocities given by Eq. (1); and, in addition it puts the limiting velocity at c where it belongs. Taking a time derivative of Eq. (2) or (1) gives

$$dU/dt = -\mathbf{V} \cdot \mathbf{F}_W, \quad (3)$$

where $\mathbf{V} = \mathbf{v} - \mathbf{v}'$ is the relative velocity between the charges and \mathbf{F}_W is the Weber force on charge q at \mathbf{r} due to q' at \mathbf{r}' given to order v^2/c^2 by

$$c^2 \mathbf{F}_W = (qq'R/R^3) \{c^2 + V^2 - 3(\mathbf{V} \cdot \mathbf{R})^2/2R^2 + \mathbf{R} \cdot d\mathbf{V}/dt\}, \quad (4)$$

This force (4) clearly obeys Newton's third law, being directed along \mathbf{R} and changing sign when primed and unprimed coordinates are exchanged. Since the force is derived from a potential; energy is conserved. It is the *only* electromagnetic theory ever proposed that can conserve energy for an isolated system of moving charges. This result (4) is found to be in agreement with an amazingly large number of different experimental situations.⁽⁴⁾⁽⁵⁾ It works for slowly changing effects where time retardation is not required and action at a distance remains valid. Time intervals of interest are assumed to be such that $\Delta t \gg L/c$, where L is the dimension of the laboratory.

1.1 Weber force for conductors

The force on an element of a conductor at \mathbf{r} containing q_i stationary positive ions and $-q_e$ mobile negative electrons due to an element of a conductor at \mathbf{r}' containing q'_i stationary positive ions and $-q'_e$ mobile negative electrons is obtained by adding the four forces involved, as given by Eq. (4); thus,

$$\begin{aligned} c^2 \mathbf{F}_W = (R/R^3) \{ & c^2(q_i - q_e)(q'_i - q'_e) - (q_i - q_e)q'_e [v'^2 - 3(\mathbf{v}' \cdot \mathbf{R})^2/2R^2 \\ & - \mathbf{R} \cdot d\mathbf{v}'/dt] - (q'_i - q'_e)q_e [v^2 - 3(\mathbf{v} \cdot \mathbf{R})^2/2R^2 + \mathbf{R} \cdot d\mathbf{v}/dt] \\ & + q_e q'_e [-2\mathbf{v} \cdot \mathbf{v}' + 3(\mathbf{v} \cdot \mathbf{R})(\mathbf{v}' \cdot \mathbf{R})/R^2] \}, \end{aligned} \quad (5)$$

where \mathbf{v} and \mathbf{v}' are the velocities of the electrons. The first term on the right of Eq. (5) is simply the Coulomb's law for the force between charged conductors.

Ampere's original empirical force law⁽⁴⁾ is given by Eq. (5) when no net static charges are on the conductors, or when $q_i = q_e$ and $q'_i = q'_e$; thus,

$$c^2 \mathbf{F}_A = (q_e q'_e R/R^3) [-2\mathbf{v} \cdot \mathbf{v}' + 3(\mathbf{v} \cdot \mathbf{R})(\mathbf{v}' \cdot \mathbf{R})/R^2]. \quad (6)$$

As for the general Weber theory, Eqs. (4) or (5), the Ampere law (6) is seen to obey Newton's third law.

Faraday electromagnetic induction involves the electromotive force around a loop induced by the time rate of change of current dI'/dt in another loop. From Eq. (5) this e.m.f. becomes

$$- \oint ds \cdot \oint (dI'/dt) \mathbf{R} (\mathbf{R} \cdot d\mathbf{s}')/c^2 R^3 = -(\partial/\partial t) \oint ds \cdot \oint I' d\mathbf{s}'/c^2 R \quad (7)$$

which is seen to be equal to $-\partial\Phi/\partial t$ where Φ is the magnetic flux through the unprimed loop due to the primed loop. The more general unipolar induction is considered in Section 7 below. It may be noted from Eq. (5) that there is also a ponderomotive force due to $-q'_e$ accelerating when $(q_i - q_e)$ is nonzero. In addition, there is an inverse effect given by the force on electrons $-q_e$ with an acceleration $d\mathbf{v}/dt$ due to a static charge $(q'_i - q'_e)$.

The velocity squared terms, involving v'^2 , $(\mathbf{v}' \cdot \mathbf{R})^2/R^2$, v^2 , and $(\mathbf{v} \cdot \mathbf{R})^2/R^2$, represent very small forces⁽³⁾ that are always exactly cancelled out by static charges induced in the current carrying conductor, as proved in Section 1.3 below. These velocity squared terms may, thus, always be neglected for conduction currents.

Replacing point charges by charge and current densities, the Weber force on a unit volume d^3r at \mathbf{r} containing the charge and current densities ρ and \mathbf{J} due to charge and current densities ρ' and \mathbf{J}' in a volume element d^3r' at \mathbf{r}' becomes from Eq. (5), dropping the velocity squared terms,

$$\begin{aligned} c^2 d^6 \mathbf{F}_W / d^3r d^3r' = (R/R^3) \{ & c^2 \rho \rho' - 2\mathbf{J} \cdot \mathbf{J}' + 3(\mathbf{R} \cdot \mathbf{J})(\mathbf{R} \cdot \mathbf{J}')/R^2 \\ & - \rho \mathbf{R} \cdot \partial \mathbf{J}' / \partial t + \rho' \mathbf{R} \cdot \partial \mathbf{J} / \partial t \}. \end{aligned} \quad (8)$$

The effect of moving conductors may be also deduced from Eq. (4).⁽³⁾ Pseudo-effects, where charge and current *densities* change but there is no corresponding charge motion, may also be taken into account.⁽³⁾

1.2 Wesley's generalization of Weber's theory to fields and radiation

Weber's original theory, given by Eqs. (1), (4) and (5), refers to slowly changing effects where time retardation may be neglected. In particular, no significant changes occur during time intervals of the order of $\Delta t = L/c$, where L represents the linear size of the laboratory. Wesley⁽²⁾⁽³⁾ has generalized this Weber theory to include electromagnetic fields and time retardation. Thus, Eq. (8) may be written as

$$c d^3 F_{\mu} / d^3 r = -c \nabla \Phi + \mathbf{J} \times (\nabla \times \mathbf{A}) - \rho \partial \mathbf{A} / \partial t - \mathbf{J} \nabla \cdot \mathbf{A} + (\partial \mathbf{J} / \partial t) \Phi / c + (\mathbf{J} \cdot \nabla) \nabla \Gamma + \rho \nabla \partial \Gamma / \partial t - [(\partial \mathbf{J} / \partial t) \cdot \nabla] \mathbf{G} / c, \quad (9)$$

where the scalar and vector potentials Φ and \mathbf{A} have their usual meanings,

$$\begin{aligned} \Phi &= \int d^3 r' \rho'(\mathbf{r}', t^*) / R, \\ c \mathbf{A} &= \int d^3 r' \mathbf{J}'(\mathbf{r}', t^*) / R, \end{aligned} \quad (10)$$

where

$$t^* = t - R/c, \quad (11)$$

is the retarded time and the scalar and vector potentials Γ and \mathbf{G} are defined by

$$\begin{aligned} c \Gamma &= \int d^3 r' \mathbf{R} \cdot \mathbf{J}'(\mathbf{r}', t^*) / R, \\ \mathbf{G} &= \int d^3 r' \mathbf{R} \rho'(\mathbf{r}', t^*) / R. \end{aligned} \quad (12)$$

Due to the time retardation the fields defined by Eqs. (10) and (12) can include fields propagating and radiating with the velocity c .

A further modification is needed to include the effect of absolute space or the lumeniferous ether. The velocity of energy propagation of

electromagnetic waves is known to be c fixed with respect to absolute space from the observations of Roemer,⁽⁵⁾ Bradley,⁽⁶⁾ Sagnac,⁽⁷⁾ Michelson and Gale,⁽⁸⁾ Conklin,⁽⁹⁾⁽¹⁰⁾ Marinov with his coupled mirrors experiment,⁽¹¹⁾ and Marinov with his toothed wheels experiment.⁽¹²⁾ The Michelson-Morley result⁽¹³⁾ was predicted by Voigt⁽¹⁴⁾ in 1887 as a nonclassical Doppler effect using absolute space and time. As shown by Wesley,⁽³⁾⁽¹⁵⁾ the Voigt-Doppler effect for an observer moving with the absolute velocity \mathbf{v}_0 in the positive x direction and source moving with the absolute velocity \mathbf{v}_s is given by

$$\begin{aligned} \mathbf{k}' &= k_s \frac{\gamma_0 (c_x - v_0) \mathbf{e}_x + c_y \mathbf{e}_y + c_z \mathbf{e}_z}{c \gamma_s (1 - \mathbf{v}_0 \cdot \mathbf{c} / c^2) (1 - \mathbf{v}_s \cdot \mathbf{c} / c^2)}, \\ \omega' &= \omega_s \gamma_s (1 - \mathbf{v}_0 \cdot \mathbf{c} / c^2) / \gamma_s (1 - \mathbf{v}_s \cdot \mathbf{c} / c^2), \\ \mathbf{c}' &= (c_x - v_0) \mathbf{e}_x + (c_y \mathbf{e}_y + c_z \mathbf{e}_z) / \gamma_0, \\ \mathbf{c}^* &= \mathbf{c} - \mathbf{v}, \end{aligned} \quad (13)$$

where \mathbf{k}' is the observed propagation constant, $k_s = \omega_s / c$ where ω_s is the angular frequency of the source, \mathbf{c}' is the observed phase velocity, \mathbf{c}^* is the observed velocity of energy propagation, \mathbf{e}_x , \mathbf{e}_y , and \mathbf{e}_z are unit vectors in the Cartesian coordinate directions, $\gamma_0 = 1 / \sqrt{1 - v_0^2 / c^2}$ and $\gamma_s = 1 / \sqrt{1 - v_s^2 / c^2}$, and ω' is the observed angular frequency. The motion of the source only modifies the frequency and wavelength of emitted radiation as a function of direction. The light, once emitted, then propagates without change with the fixed velocity c with respect to absolute space. The major effect arises from the motion of the observer with respect to absolute space. For most purposes Eq. (11) for the retarded time need only be modified by replacing c by the phase velocity c' , thus

$$c \rightarrow c' = c(1 - \mathbf{v}_0 \cdot \mathbf{c} / c^2), \quad (14)$$

to take into account this effect of the motion of the observer with respect to absolute space.

1.3 Force on a static charge due to a steady conduction current

It has been argued that the Weber theory is wrong, because it predicts a force between a stationary charge and a steady current; and no such force has ever been observed. More precisely, no force between a conduction current and a stationary charge has been observed. The Fechner hypothesis that a conduction current consists of equal amounts of positive and negative charges flowing in opposite directions (which is now known to be false) was introduced to yield zero force between a stationary charge and a conduction current. The Fechner hypothesis is, however, unnecessary. The "velocity squared" forces are simply much too small to be readily observed.

From Eq. (5) the Weber force on a stationary charge q due to a charge q' moving with the steady velocity v' is given by

$$c^2 F_w = - (qq'R/R^3) [v'^2 - 3(v' \cdot R)^2 / 2R^2]. \quad (15)$$

Although this force can be observed on an isolated moving charge in the presence of a static charge distribution, as discussed in Sections 8 and 9 below; it is not clearly seen using conduction currents. To show why it will be sufficient to consider a special case of an infinitely long straight wire carrying a steady current I . It may be shown from Eq. (15) that the force per unit charge, the electric field E , is radial and at the distance r from the center of the wire it is⁽⁵⁾

$$E = - Iv'/c^2 r = - (I^2/c^2 e \rho_N A)/r, \quad (16)$$

where e is the electron charge, ρ_N is the number density of electronic carriers and $A = \pi a^2$ is the cross-sectional area of the wire of radius a . This is equivalent to the wire with a negative charge Q per unit length L ; thus,

$$Q/L = - I^2/c^2 e \rho_N A. \quad (17)$$

If a metal cylinder of radius $b > a$ and length L is put around the

wire, a cylindrical capacitor is formed which will have a potential

$$V = Q/C = - \ln(b/a) I^2/c^2 e \rho_N A, \quad (18)$$

where the capacitance is $C = L/\ln(b/a)$. The magnitude of this Weber force may then be estimated by considering the potential induced for a copper wire of $A = 1 \text{ cm}^2$ cross sectional area carrying a current of $I = 10^3$ amp where $b/a = 1.1$. Assuming the number of electron carriers in copper per atomic weight is roughly Avogadro's number, for this case

$$V = 7 \times 10^{-9} \text{ volt}, \quad (19)$$

which seems much too small to ever be detected. However, Edwards⁽¹⁸⁾ claims to have observed an effect of this order of magnitude varying as I^2 . Unfortunately it is quite impossible to discover from his badly written paper what his experiment might have been; and there is no way to make a proper evaluation of his claims.

The charges inside the metal wire also experience the Weber force. In particular, the electric field due to this force inside the infinitely long wire at a distance r from the center of the wire, as determined by the moving charges inside this radius, is

$$E = - \pi r J^2/c^2 e \rho_N, \quad (20)$$

where a uniform current density $J = I/A$ has been assumed. As is well known a static electric field cannot be maintained in a conductor, because charges flow until the field is zero. Consequently, a uniform positive charge density is induced in the conductor that exactly cancels the field produced by the Weber force between a stationary charge and a current; thus,

$$\rho(\text{charge}) = + J^2/c^2 e \rho_N. \quad (21)$$

The net radial electric field inside the wire is then zero, as it should be.

Outside the wire the radial electric field produced by this positive charge distribution (21) is

$$E(\text{charge}) = +\rho(\text{charge})A/r = (I^2/c^2 e \rho_H A)/r. \quad (22)$$

To conserve charge a negative surface charge density must be induced on the surface of the wire, which is precisely equal to Eq.(17). Thus, there are three sources of an electric field present: the velocity squared force given by Eq.(16), the internal uniform positive charge distribution given by Eq.(21), and the negative surface charge density given by Eq.(17). Inside the wire these three fields yield a zero net electric field, as they should. Outside the wire the field due to the charge separation is zero (the net charge on the wire being zero), leaving only the velocity squared field alone, which is given by Eq.(16).

2. MAXWELL-LORENTZ ELECTRODYNAMICS

According to Maxwell-Lorentz electrodynamics⁽¹⁹⁾⁽²⁰⁾⁽²¹⁾ the force on an element of volume d^3r at \mathbf{r} containing a charge and current density ρ and \mathbf{J} is given by the Lorentz force

$$c^2 d^3F_H/d^3r = -c\rho \nabla\phi - \rho \partial \mathbf{A}/\partial t + \mathbf{J} \times (\nabla \times \mathbf{A}), \quad (23)$$

where the scalar and magnetic potentials ϕ and \mathbf{A} are defined by Eqs. (10). Combining Eqs. (23) and (10), the Maxwell-Lorentz force on a volume element d^3r at \mathbf{r} with charge and current densities ρ and \mathbf{J} due to a volume element d^3r' at \mathbf{r}' with charge and current densities ρ' and \mathbf{J}' becomes

$$c^2 d^6F_H/d^3r d^3r' = c^2 \rho \rho' R/R^3 - \rho (\partial \mathbf{J}'/\partial t)/R - (\mathbf{J} \cdot \mathbf{J}')R/R^3 + (\mathbf{R} \cdot \mathbf{J})\mathbf{J}'/R^3. \quad (24)$$

In terms of charges, the Maxwell-Lorentz force on a charge q with velocity \mathbf{v} at \mathbf{r} due to a charge q' with velocity \mathbf{v}' at \mathbf{r}' is given by

$$c^2 F_H = qq' \left[c^2 R/R^3 - (d\mathbf{v}'/dt)/R - (\mathbf{v} \cdot \mathbf{v}')R/R^3 + (\mathbf{R} \cdot \mathbf{v}')\mathbf{v}'/R^3 \right]. \quad (25)$$

These Eqs. (24) and (25) may be compared with the corresponding Weber

expressions given by Eqs. (8) and (4). Time retardation has been neglected here; Eqs. (24), (25), (8), and (4) all refer to slowly varying effects.

It may be seen from the second and fourth terms on the right of Eq. (25) that the Maxwell-Lorentz force between point charges violates Newton's third law; as these forces do not act along the line \mathbf{R} joining the two charges, and interchanging primes and unprimes does not yield merely a change of sign. It should be remarked that a failure to obey Newton's third law is a very serious matter; as it implies drastic consequences, such as the violation of the conservation of energy, the ability to propel a space craft using only forces internal to the space craft itself, and the ability to lift oneself by one's own boot straps. Even a casual glance at Eq. (25) is, thus, sufficient to show that the Maxwell-Lorentz theory cannot be based solely upon the forces between isolated point charges, in contrast to the Weber theory. In addition, as will be shown below, Eqs. (24) and (25) do not agree with the experimental evidence. The Maxwell theory, being incapable of prescribing the correct force between two moving point charges, cannot be regarded as a fundamental theory. The special situations and limiting conditions under which the Maxwell theory works are outlined below in Section 2.3.

2.1 Biot-Savart law

The Biot-Savart law is given by the last two terms on the right of Eq. (24) or (25),

$$c^2 d^6F_B/d^3r d^3r' = \mathbf{J} \times (\mathbf{J}' \times \mathbf{R})/R^3, \quad \text{or} \quad c^2 F_B = qq' \mathbf{v} \times (\mathbf{v}' \times \mathbf{R})/R^3. \quad (26)$$

This is the Maxwell-Lorentz force for steady currents, the magnetostatic case. As is well known, this law (26) violates Newton's third law. Grassmann⁽²⁰⁾ (who apparently was the first to propose the Biot-Savart law) justified the law as follows: 1) It is mathematically simpler than Ampere's law (6). 2) It yields precisely the same result as the Ampere law (6) when the source current \mathbf{J}' is integrated around a closed current loop; and, thus, it obeys Newton's third law when integrated around a closed current loop. 3) And all currents necessarily form closed current loops.

Considering Grassmann's first point, it is not at all apparent that

the Biot-Savart law is mathematically simpler; in some instances it yields greater mathematical difficulties. Considering Grassmann's second point, if the Ampere and Biot-Savart laws were equivalent (which they are not), the Ampere law, obeying Newton's third law from the outset, should be chosen in preference to the Biot-Savart law, which violates Newton's third law and can only satisfy Newton's third law after being integrated around a closed current loop. Considering Grassmann's third point, not all currents form closed current loops. For example, the currents in the Z-shaped Pappas-Vaughan antenna, considered below, do not form closed current loops. Moving point charges need not form closed current loops. In addition, it is the *mechanical force* that must be integrated around a closed loop to make the Biot-Savart law satisfy Newton's third law; the existence or nonexistence of a closed *current* loop is not necessarily relevant.

Ampere⁽⁴⁾ recognized this point early. He demonstrated this with the force on a hairpin shaped wire (the Ampere bridge) with ends making electrical contact in two troughs with mercury, as shown in Fig. 1.

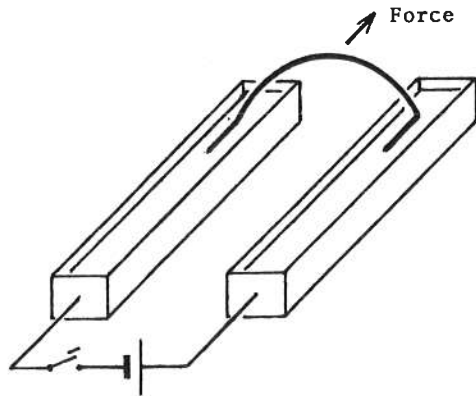

Figure 1. Diagram of the experiment Ampere performed to refute the Biot-Savart law. The force on the bridge when current flows is in the direction indicated.

The bridge is repelled down the troughs when current is sent through the bridge. Although a closed current loop is involved; the net force on the bridge is obtained by integrating the elements of force only over the bridge and not around the entire current loop. The Ampere bridge is propelled by the repulsive forces between colinear current elements as given by Ampere's law (6). No such force is predicted by the Biot-Savart law (26); as the force on a current element is supposed to be always normal to the element. The Ampere tension or repulsion between colinear current elements also accounts quantitatively for the force necessary to rupture current carrying wires as observed by Graneau.⁽²¹⁾⁽²²⁾⁽²³⁾ In addition, the Ampere repulsion accounts for the force that drives the Graneau-Hering submarine.⁽²⁴⁾⁽²⁵⁾ And finally, the Ampere repulsion yields the force that drives the mercury in Hering's pump.⁽²⁵⁾

It may be readily demonstrated that the Biot-Savart law is *absurd*.⁽²⁶⁾ The Biot-Savart law predicts a net nonvanishing self force on a closed current loop. Dividing a current carrying loop mathematically into two portions 1 and 2, the element of force on a current element $I ds$ on portion 1 (due to a current element $I ds'$) plus the element of force on current element $I ds'$ on portion 2 (due to a current element $I ds$); as given by Eq. (26), may be integrated to yield the total self force on the current loop as

$$c^2 F_B = I^2 \int_1 \int_2 \left\{ \frac{[ds \times (ds' \times R)]}{R^3} - \frac{[ds' \times (ds \times R)]}{R^3} \right\} \tag{27}$$

$$= - I^2 \int_1 \int_2 \frac{R \times (ds \times ds')}{R^3}.$$

Depending upon how one chooses portions 1 and 2, one can obtain a nonvanishing force with any value at all (within limits). Such a loop would be very convenient to drive an automobile or propel a space ship. One could obtain the desired magnitude of the force without having to change anything physically; one need only alter the mathematical labels. In addition, using the criteria that Grassmann provides that the force between current elements, when integrated around a closed current loop should yield the Ampere result, a completely equivalent 'Biot-Savart law' is given by

$$c^2 d^2 \mathbf{F}_g = I^2 d\mathbf{s}' \times (d\mathbf{s} \times \mathbf{R})/R^3, \quad (28)$$

where $d\mathbf{s}$ and $d\mathbf{s}'$ are interchanged as compared with Eq. (26) or (27). Using this equivalent 'Biot-Savart law' the net self force on a closed current loop becomes the negative of Eq. (27). The *absurdity* is complete.

2.2 Faraday's law of electromagnetic induction

The Maxwell-Lorentz force on a charge due to a time changing current or an accelerating charge, the second term in Eq. (24) or (25), does not obey Newton's third law. Thus, the Maxwell-Lorentz theory again fails; it cannot correctly predict the force between a stationary charge and an accelerating charge. However, it can predict the correct electromotive force around a closed loop due to another closed loop with current changing with time, the Faraday law of electromagnetic induction; thus,

$$\text{e.m.f.} = - \oint d\mathbf{s} \cdot \partial \mathbf{A} / \partial t = - (\partial / \partial t) \int d\mathbf{a} \cdot \mathbf{B} = - \partial \Phi / \partial t. \quad (29)$$

This integral result (29) satisfies Newton's third law. Again, as for the Biot-Savart law, it is a matter of integrating an incorrect formula around a closed loop to get a correct result. This result (29) is identical to the Weber result (7).

Both the Maxwell-Lorentz theory and the Weber theory⁽³⁾ can predict pseudo-effects where no charge acceleration occurs, but the source loop is moved with a velocity \mathbf{v}' ; so $d\mathbf{A}/dt = \partial \mathbf{A} / \partial t + (\mathbf{v}' \cdot \nabla) \mathbf{A} \neq 0$; and an e.m.f. is induced.

The Maxwell-Lorentz theory is completely incapable of predicting localized unipolar induction (discussed in Section 7 below). The Weber theory, on the other hand, easily predicts all of the experimental results of Kennard and Müller.

2.3 Limitations of the Maxwell-Lorentz theory

From the discussion above (and to follow) it may be seen that for slowly varying effects the Maxwell-Lorentz theory is valid only for limited situations where:

1) The interaction between moving point charges is *not* involved. It does not, thus, provide valid expressions for the interaction between moving point charges in submicroscopic systems, where quantum theory is required.

2) Macroscopic quantities of material and macroscopic distributions

of charge and currents are involved.

3) A source is confined to a finite volume, and it vanishes on the surface of this volume.

4) A detector is confined to another finite volume. Sources and detectors do not occur in the same volume.

5) As implied by limitations 3) and 4), source currents form closed current loops so that $\nabla \cdot \mathbf{A} = \Gamma = 0$.

6) The force on an accelerating charge or time varying current due to a static charge distribution is not involved.

7) Induction is limited to closed current loops due to the net time rate of change of the magnetic flux (produced elsewhere) through the loop.

8) Induction in only a portion of a closed loop is not involved.

9) Induction in open circuits is not involved.

For rapidly varying effects, where time retardation is required, the limitations listed above still appear to be valid. It is not evident, however, that retarded fields Φ and \mathbf{A} , Eqs. (10), are ever sufficient. It may be that the retarded fields Γ and \mathbf{G} , Eqs. (12), are also needed for completeness, such as for the self-torque on the Pappas-Vaughan antenna (Section 6 below).

In contrast to these limitations, the Weber-Wesley theory, being a fundamental theory, appears to have no limitations at all.

3. QUANTITATIVE DETERMINATION OF THE FORCE ON AMPERE'S BRIDGE

A crucial experiment that decides between Ampere's original empirical law (6), (30), or (31) for the force between current elements and the Biot-Savart law (26) (and, thus, helps to decide between the Maxwell-Lorentz theory and the Weber-Wesley theory) involves the measurement of the force on Ampere's bridge, as indicated in Fig. 1. Ampere,⁽⁴⁾ Hering,⁽²⁵⁾ Cleveland,⁽²⁷⁾ Robertson,⁽²⁸⁾ Pappas,⁽²⁹⁾⁽³⁰⁾ and Graneau⁽¹⁴⁾⁽³¹⁾⁻⁽³³⁾ have shown that the bridge is repelled by the remainder of the circuit, as would be expected from Ampere's law. But these earlier experiments yielded no adequate *quantitative* measurements.

The difficulties in obtaining *quantitative* results have been both experimental and theoretical. A valid expression for the force on Ampere's bridge derived from Ampere's law (31) that can be compared

quantitatively with experiment has only been recently available.⁽³⁾ And only recently have Moyssides and Pappas⁽³⁴⁾ obtained quantitative results for the force on Ampere's bridge that can be adequately compared with the theory. The theoretical difficulties in the past⁽²³⁾⁽²⁷⁾⁻⁽³³⁾ arose from using Ampere's law written for linear current elements, which from Eq. (6), letting $q\mathbf{v} = I\mathbf{ds}$ and $q'\mathbf{v}' = I'\mathbf{ds}'$, is

$$c^2 d^2 F_A = (II'R/R^3) \left[-2\mathbf{ds} \cdot \mathbf{ds}' + 3(\mathbf{ds} \cdot \mathbf{R})(\mathbf{ds}' \cdot \mathbf{R})/R^2 \right]. \quad (30)$$

This linear form (30) yields an *infinite* force when two colinear current elements are brought together, the force varying as the inverse square of the separation distance. This infinite force arises from having assumed *infinite* current densities, finite currents I and I' being confined to wires of vanishing cross section. The infinities can be avoided by turning to volume current densities, where the Ampere law (6) or (30) becomes

$$c^2 d^6 F_A / d^3 r d^3 r' = (R/R^3) \left[-2\mathbf{J} \cdot \mathbf{J}' + 3(\mathbf{J} \cdot \mathbf{R})(\mathbf{J}' \cdot \mathbf{R})/R^2 \right]. \quad (31)$$

It may be readily shown that integrating this form of Ampere's law (31), using continuous finite current densities \mathbf{J} and \mathbf{J}' , can yield no infinities, in agreement with laboratory observations.

3.1 Ampere prediction of the force on Ampere's bridge with straight ends

The force on Ampere's bridge with straight ends with the geometry shown in Fig. 2 has been calculated⁽³⁾ by performing all 6 of the integrations indicated in Eq. (31). The analysis is lengthy but straightforward. All integrations yield expressions in closed form. When the width w , equal to the laminar thickness, is small the magnitude of the force is given by

$$c^2 F_A / 2I^2 = C + \sqrt{1 + L^2/M^2} - \ln(1 + \sqrt{1 + L^2/M^2}) + \ln(L/w), \quad (32)$$

where $C = 13/12 - \pi/3 + (2/3) \ln 2 = 0.49822 \dots$, and the dimensions L , M , N , and w are indicated in Fig. 2.

The lower portion of the circuit diagrammed in Fig. 2 also forms an Ampere's bridge. The force on this lower portion is given by merely changing the sign of Eq. (32) and replacing N by $M - N$. Since N does

not occur, the force on the lower portion is simply the negative of Eq. (32). The net force on the current loop is zero; and Newton's third law is satisfied.

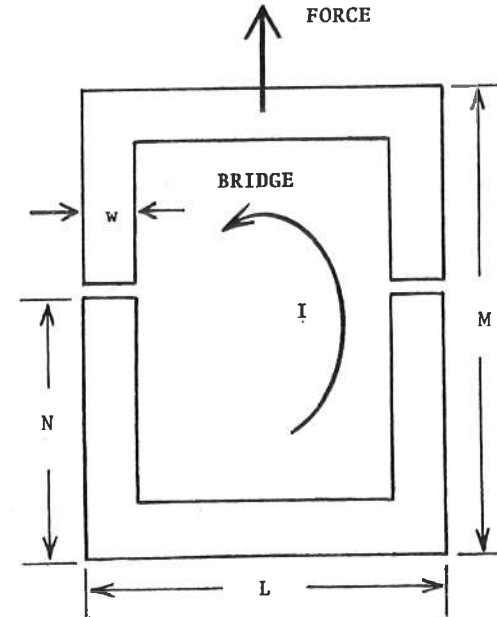

Figure 2. Diagram of Ampere's bridge with straight ends showing the dimensions L , M , N , and w .

3.2 Biot-Savart prediction of the force on Ampere's bridge with straight ends

Carrying out the 6 necessary integrations indicated by the first of Eqs. (26) for the Ampere bridge as diagrammed in Fig. 2, the Biot-Savart law predicts a force on the bridge for the width w , equal to the laminar thickness, small equal to

$$c^2 F_B / 2I^2 = -1 + \sqrt{1 + L^2/M^2} - \ln(1 + \sqrt{1 + L^2/M^2}) + \ln(1 + \sqrt{1 + L^2/(M-N)^2}). \quad (33)$$

This result (33) is quite different from the Ampere result (32); as may be readily seen for the case where L/M and $L/(M-N) \rightarrow 0$. In this case the Ampere result is large and varies as $\ln(L/w)$, while the Biot-Savart result becomes zero. The strong repulsive force observed⁽⁴⁾⁽¹⁴⁾⁽²⁵⁾⁽²⁷⁾⁻⁽³³⁾ is in agreement with the Ampere prediction. The experimental observations do not agree with the weak or zero Biot-Savart prediction.

Actually this result (33) is *absurd*: From symmetry the lower portion of the circuit diagrammed in Fig. 2 also forms an Ampere's bridge which experiences a Biot-Savart force given by changing the sign of Eq. (33) and replacing $M-N$ by N . The net Biot-Savart self force on the entire circuit is then suppose to be nonzero and equal to

$$c^2 F_B(\text{net})/2I^2 = \ln(1 + \sqrt{1 + L^2/(M-N)^2}) - \ln(1 + \sqrt{1 + L^2/N^2}). \quad (34)$$

Newton's third law is not obeyed. This force (34) could be used to lift oneself by ones own boot straps, to violate the conservation of energy, etc. This result (34) is a specific example of the *absurdity* already demonstrated above by Eqs. (27) and (28).

3.3 The force on Ampere's bridge with bent ends

Moyssides and Pappas⁽³⁴⁾ also measured the force on Ampere's bridge with bent ends, as shown in Fig. 3. Using Ampere's law as given by Eq. (31), the 6 integrations may again be carried out in closed form. For the width w , equal to the lamina thickness, small the force on the bridge becomes

$$\begin{aligned} c^2 F_A / 2I^2 = & \ln((L-P)/P) + \ln(Q/(Q-P)) + \sqrt{1 + Q^2/N^2} - \sqrt{1 + Q^2/M^2} \\ & + \sqrt{1 + Q^2/(M-N)^2} - \sqrt{1 + (L-Q)^2/N^2} + \sqrt{1 + (L-Q)^2/M^2} \\ & - \sqrt{1 + (L-Q)^2/(M-N)^2} - \sqrt{1 + P^2/N^2} - \sqrt{1 + (Q-P)^2/(M-N)^2} \\ & + \sqrt{1 + (L-Q-P)^2/(M-N)^2} + \sqrt{1 + (L-P)^2/N^2} - \ln((L-Q)/(L-Q-P)) \\ & + \ln\left[\frac{1 + \sqrt{1 + (L-Q)^2/N^2}}{1 + \sqrt{1 + Q^2/N^2}}\right] - \ln\left[\frac{1 + \sqrt{1 + (L-Q)^2/M^2}}{1 + \sqrt{1 + Q^2/M^2}}\right] \\ & - \ln\left[\frac{1 + \sqrt{1 + (L-P)^2/N^2}}{1 + \sqrt{1 + P^2/N^2}}\right] - \ln\left[\frac{1 + \sqrt{1 + Q^2/(M-N)^2}}{1 + \sqrt{1 + (Q-P)^2/(M-N)^2}}\right] \\ & + \ln\left[\frac{1 + \sqrt{1 + (L-Q)^2/(M-N)^2}}{1 + \sqrt{1 + (L-Q-P)^2/(M-N)^2}}\right]. \end{aligned} \quad (35)$$

Although this result (35) is a bit lengthy with 5 parameters; numerical results may be readily obtained to compare with experiment.

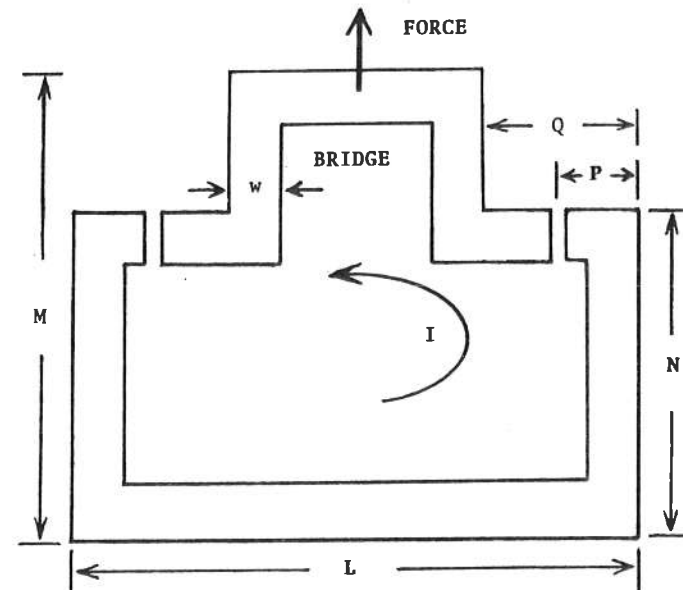

Figure 3. Diagram of Ampere's bridge with bent ends showing the dimensions L , M , N , P , Q , and w .

3.4 Comparison of theory with experiment for the force on Ampere's bridge with straight ends

The theory assumes a rectangular cross section for the wire used; whereas Moyssides and Pappas⁽³⁴⁾ actually used wires of circular cross section. To an adequate approximation the small cross-sectional areas may be equated; or

$$w = \sqrt{\pi} d/2, \quad (36)$$

where d is the diameter of the circular wire used. Moyssides and Pappas used $L = 48$ cm and $M = 120$ cm. They used units of gram weight for the force F_A ; so Eq. (32) must be divided by the acceleration of gravity 980.0 cm/sec². They used units of ampere for the current instead of electrostatic units; so Eq. (32) must also be multiplied by $c^2/100$. Using Eq. (36) and the above facts, Eq. (32) yields the theoretical formula

$$F_A/I^2 = (14.569 - 2.0408 \ln d) \times 10^{-5}, \quad (37)$$

where F_A is the force in gram weight units, I is the current in amperes, and d is the wire diameter in millimeters. This theoretical result (37) is plotted in Fig. 4, where it is compared with the experimental points of Moyssides and Pappas⁽³⁴⁾ (as presented in their Fig. 3).

3.5 Comparison of theory with experiment for Ampere's bridge with bent ends

For the case of 1 cm bent ends $Q - P = 1$ cm, $L = 52$ cm, $P = 1$ cm, $M = 120$ cm, and $N = 43$ cm Moyssides and Pappas⁽³⁴⁾ report a force on the Ampere bridge per current squared of $7.04 \pm 0.14 \times 10^{-5}$ gm weight/amp², where the error has been estimated from their Fig. 11. Substituting the dimensions reported by Moyssides and Pappas into Eq. (35) yields the theoretical prediction of 9.500×10^{-5} gm weight/amp². Similarly for the case of 2 cm bent ends where $Q - P = 2$ cm, $L = 54$ cm, $P = 1$ cm, $M = 120$ cm, and $N = 43$ cm Moyssides and Pappas report a force per current squared of $6.06 \pm 0.12 \times 10^{-5}$ gm weight/amp². The theoretical prediction in this case from Eq. (35) is 9.019×10^{-5} gm weight/amp². Results are summarized in Table 1.

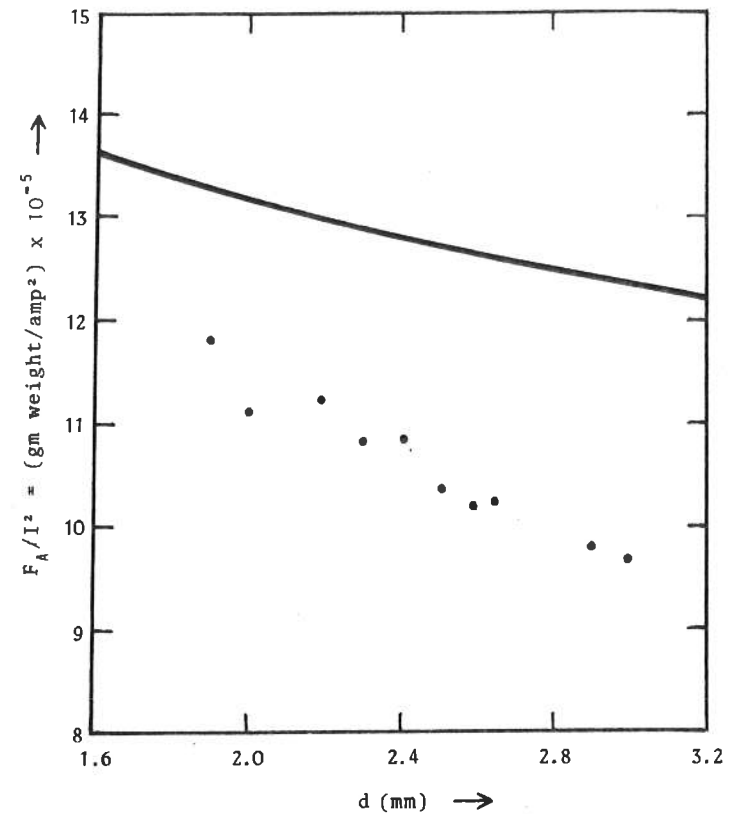

Figure 4. Force on Ampere's bridge with straight ends, theory (solid curve), Eq. (37), compared with the experimental points.

Table 1. Force on Ampere's bridge with bent ends (gm weight/amp²) $\times 10^{-5}$

length of bent ends	experiment	theory, Eq. (35)
1 cm	7.04 ± 0.14	9.500
2 cm	6.06 ± 0.12	9.019

3.6 Discussion and conclusions concerning the measurement of the force on Ampere's bridge

Examining Fig. 4 and Table 1, it may be seen that the predicted force exceeds the force reported by Moyssides and Pappas by about 2.4×10^{-5} gm weight/amp² or 20 percent. Considering the well established success of the original Ampere law (30) or (31) in accurately predicting a vast amount of experimental data where the force on a closed current loop is involved (the Maxwell case), a reason must be sought for the discrepancy. The discrepancy is found to behave in a very regular way. For all 11 observations of the force on Ampere's bridge as a function of the wire diameter for the case of straight ends, as well as for the case of bent ends, the discrepancy, $\Delta = (F_A/I^2)(\text{theory}) - (F_A/I^2)(\text{experiment})$, is given quite accurately to within the experimental error by

$$\Delta = 4.57 - 0.2(F_A/I^2)(\text{theory}), \quad (38)$$

in (gm weight/amp²) $\times 10^{-5}$. Since this result (38) is independent of the many independent variables, the shape and dimensions of the circuit and the diameter of the wire; there must be a systematic error involved in the measurement of the force F_A and or else the current I . Since it seems unlikely that there could be any systematic error involving the current I ; only the measurement of the force F_A comes into question. The systematic error might arise from phenomena in the mercury cup. The current may spread out in the cup, thereby reducing the force. Surface tension of the mercury may restrain the free motion of the bridge, resulting in apparent smaller forces. The fractional effect of surface tension should be greater for smaller forces as is observed.

Since the discrepancy between theory and experiment does not depend upon the particular expression used, Eq. (32) or (35), nor upon a variation of the parameters; it is quite legitimate to use Eq. (38) to correct for the systematic experimental error that is clearly present. Making the correction, it is concluded that the experimental determination of the force on Ampere's bridge by Moyssides and Pappas⁽³⁴⁾ confirms Ampere's original force law (6) or (31) *quantitatively* to within the experimental error of about 2 percent. Even without the correction the result confirms Ampere's law *quantitatively* to within a 20 percent error.

4. AMPERE REPULSION AND GRANEAU'S EXPLODING WIRES

Graneau⁽²¹⁾⁽²²⁾ reports the breaking of wires (and liquids⁽²³⁾) when loaded with large currents. He attributes this explosion of wires (and liquids) to the Ampere repulsion between colinear current elements. In an attempt to estimate the tension Graneau incorrectly uses the linear form of Ampere's law (30). To avoid the inevitable infinities Graneau introduces into his computer calculations a nonvanishing arbitrary finite length for his current elements. He adjusts this finite length to agree with experiment. His estimates of the Ampere tension are, thus, not valid. No arbitrary adjustable parameter arises in the correct physical theory based upon the three dimensional form of Ampere's law Eq. (31).

The present paper derives for the first time a correct theoretical estimate of the Ampere tension available to rupture a current carrying wire using the three dimensional form of Ampere's law (31). Since no infinities can arise; there is no need to introduce an arbitrary finite current element. The correct theoretical prediction supports Graneau's claim that the wires are ruptured by Ampere repulsion between colinear current elements.

The force on Ampere's bridge due to the remainder of the circuit obtained by integrating Eq. (31) for the geometry shown in Fig. 2 is given by Eq. (32). This force is independent of where the mercury cups occur along the sides of length M (shown as gaps in Fig. 2). To estimate the Ampere tension T for Graneau's setup a square circuit (without mercury cups) may be considered, where $L = M$; thus, from Eq. (32)

$$T = (I^2/c^2) \{C + \ln(L/w)\}, \quad (39)$$

where $C = 13/12 + \sqrt{2} - \pi/3 + (2/3) \ln 2 - \ln(1 + \sqrt{2}) = 1.0311\dots$. The tension in a circular loop may then be approximated by a square circuit of the same area. A wire of circular cross section may be approximated by a wire of square cross section of the same area, Eq. (36). The tensile stress S created by Ampere repulsion in a circular loop of diameter D carrying a current I in a wire of circular cross section of diameter d may then be approximated as

$$S = 4T/\pi d^2 = (4I^2/c^2\pi d^2) \{1.0311 + \ln(D/d)\}. \quad (40)$$

4.1 Comparison of the Ampere stress in a current carrying wire with the stress needed to break the wire

Graneau⁽²¹⁾ considers the case of the breaking of a current carrying straight wire of diameter $d = 1$ mm and length $L = 150$ cm carrying a current of 10^4 amp. Approximating this case by a circular circuit of diameter $D = 2L/\sqrt{\pi} = 169$ cm, Eq. (40) yields the estimate of the Ampere tension in the wire as 8.64 kgm, or an Ampere tensile stress of 11.0 kgm/mm². This is about 1/4th the tensile stress needed to break cold copper; but it is undoubtedly sufficient to impulsively break copper weakened by Joule heating.

Graneau⁽²¹⁾ also considers the case of a curved circuit which may be approximated by a circle of diameter $D = 50$ cm of 99% pure aluminum wire of diameter $d = 1.2$ mm carrying a current of 5×10^3 amp. According to Eq. (40) the Ampere tensile stress in the wire is 2.29 kgm/mm². This is about 1/9th the tensile stress needed to break cold aluminum; but it is undoubtedly sufficient to impulsively break aluminum greatly weakened by Joule heating.

4.2 Discussion and conclusions concerning exploding wires

Microscopic appearance of the clean right angle breaks that Graneau obtains indicate that rupturing occurs as a result of impulsive tensile loading and that no radial pinch effect, which would have yielded a necking-down, could be responsible for the observed ruptures.

It is sometimes speculated that the explosion of wires carrying large currents is due entirely to Joule heating of occluded gases on grain boundaries of the metal. Although this mechanism may contribute to the weakening of the tensile strength of metals; it cannot account for the explosion. No alternative methods of heating, such as microwaves, even to melting, have ever been observed to produce such explosions in metals. If it were merely a matter of Joule heating, rupturing in the radial direction should also be observed. Radial rupturing, providing less resistance to expansion, would seem to be preferred if it were merely a matter of Joule heating alone. If the effect were due to Joule heating, the ends of the broken wires should be ragged and should show some signs of melting instead of showing clean right-angle breaks indicating impulsive tensile loading. In addition, Graneau's⁽²³⁾ observation of ruptures in liquids due to Ampere tension cannot be attributed to Joule

heating of occluded gases on grain boundaries.

Ampere tension is the only force available to give rise to the observed tensile ruptures. The magnitude of the Ampere tension estimated here is of the correct order of magnitude to account for the ruptures observed. If some weakening by Joule heating is assumed, the match between theory and experiment is adequate. The absence of data on the rupture strength of metals as a function of temperature and the absence of the temperature of the wires when exploding make it impossible to check this point. In conclusion, Graneau's claim that his wires carrying large currents break due to Ampere tension is undoubtedly correct.

5. AMPERE REPULSION DRIVES THE GRANEAU-HERING SUBMARINE AND HERING'S PUMP

Hering⁽²⁵⁾ performed a number of interesting experiments that he claimed could not be adequately explained by traditional Maxwell theory. Among these experiments is the propulsion of a wedged-shaped piece of copper, or "submarine", when laid in a trough of current carrying mercury. Graneau⁽²⁴⁾ repeated this experiment and ascribed the propelling force to the repulsion between colinear current elements given by Ampere's original force law (6) or (31). Graneau did not derive a theoretical expression for the force on the submarine; nor did he measure the force *quantitatively*. The present paper derives for the first time an estimate of the force on the Graneau-Hering submarine from Ampere's original force law. A very simple experiment is proposed to verify the theory *quantitatively*.

Hering⁽²⁵⁾ also performed an experiment in which mercury is pumped uphill from a central reservoir into a narrow current carrying channel where the mercury then flows in two opposite directions into large reservoirs at either end of the narrow channel. The electric current flows in only one direction down the narrow channel; the effect is independent of the direction of the current flow. In principle, this experiment again demonstrates the propulsive force on a current carrying metal wedge. In this case the wedge is formed by the mercury from the narrow channel toward the large reservoirs. The theory derived here for the Graneau-Hering submarine is, thus, equally applicable to Hering's pump. The very simple experiment proposed below for the quantitative

force on the submarine will then also test the theory quantitatively for the Hering pump.

5.1 Theory for the propulsion of the Graneau-Hering submarine and Hering's pump

The result (32) or (39) yields the Ampere tension as proportional to the logarithm of the ratio of the size or diameter of the circuit to the size or diameter of the wire. The size of the wire enters in from the integration of Eq. (31) only in the neighborhood of the point where the tension is to be calculated. Away from this point the size of the wire is a matter of indifference in the integrations when the size of the wire is small compared with the other dimensions of the circuit. For the Graneau-Hering submarine, assuming that all of the current is funnelled through the higher conducting copper submarine, the tension, or force, T_1 at the rear end of width w_1 of the submarine is

$$T_1 = (I^2/c^2)(C' + \ln(L/w_1)), \quad (41)$$

where C' is a constant, which may be obtained from Eq. (32). The tension or force at the forward end of width $w_2 > w_1$ is

$$T_2 = (I^2/c^2)(C' + \ln(L/w_2)). \quad (42)$$

Assuming w_2 and w_1 small compared with the other dimensions of the circuit, the net force F to propel the submarine is simply

$$F = T_1 - T_2 = (I^2/c^2) \ln(w_2/w_1). \quad (43)$$

This force propels the submarine in the direction of the broader end as observed.

This result (43) may also be used to obtain the force on the mercury in Hering's pump.

5.2 Proposed experiment to measure the force available to propel a submarine or to drive a pump

The observed results of Graneau⁽²⁴⁾ and Hering⁽²⁵⁾ for the force on the Graneau-Hering submarine and the force to drive the Hering pump have been only qualitative. An appropriate quantitative prediction derived from Ampere's law as given by Eq. (32) or by Eqs. (41) and (42) can be obtained by measuring the pressure difference between the ends of a

closed wedged shape container of square cross section containing current carrying mercury as indicated in Fig. 5. The difference in tension per unit area, the pressure, can be determined by the difference in the height Δh to which the mercury rises in the two columns as indicated in Fig. 5. Since the static pressure in the mercury must be the same throughout; the mercury will rise on the end of width w_2 , where the internal Ampere pressure is less to match the higher Ampere pressure at the other end of width w_1 ; thus,

$$\rho_{Hg} g \Delta h = (I^2/c^2 w_1^2)(C' + \ln(L/w_1)) - (I^2/c^2 w_2^2)(C' + \ln(L/w_2)), \quad (44)$$

where ρ_{Hg} is the density of mercury, g is the acceleration of gravity, and C' is a constant that can be obtained from Eq. (32).

The difference in height Δh would be best measured interferometrically by comparing the optical path difference between coherent light beams reflected vertically from the mercury columns at w_2 and w_1 . In this way large currents I with extraneous heating effects could be avoided.

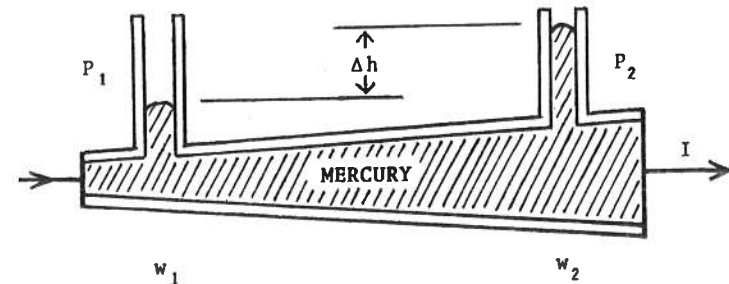

Figure 5. Proposed experiment to determine quantitatively the force available to drive the Graneau-Hering submarine or to drive Hering's pump by measuring the pressure difference between the ends of side w_1 and w_2 in a wedge shaped container of current carrying mercury.

6. MAXWELL-LORENTZ THEORY PREDICTS A NONZERO SELF-TORQUE ON THE PAPPAS-VAUGHAN ANTENNA

Pappas and Vaughan⁽³⁵⁾ have suspended a Z-shaped antenna, as shown in Fig. 6, by a 5 m long nylon fiber. No other mechanical connection to the antenna is involved. The antenna is driven inductively by an air core transformer at the center at a frequency (≈ 150 Mhz) such that the standing electromagnetic waves along the antenna have a wavelength λ (≈ 2 m) matching the dimensions of the antenna as shown in Fig. 6. When driven the antenna shows zero self-torque. The torsion balance formed by the suspended antenna is sufficiently sensitive to detect torques of only 10^{-7} Nt m.

Integrating Eq. (23), using Eqs. (10) and (11), the Maxwell-Lorentz theory predicts a readily measurable nonzero self-torque on the antenna. This predicted self-torque, which violates Newton's third law, arises from the fact that the Maxwell-Lorentz theory violates Newton's third law from the outset. The antenna does not form a closed current loop. The Pappas-Vaughan experiment, thus, provides another example of where the Maxwell-Lorentz theory fails or does not apply. In contrast, integrating Eq. (9), using Eqs. (10)-(12), the Weber-Wesley theory, satisfying Newton's third law, predicts a zero self-torque on the antenna in agreement with the experimental result.

This experiment is of special interest for comparing the Weber-Wesley theory with the Maxwell-Lorentz theory; because time retardation is involved together with electromagnetic fields. The other experimental situations considered in this paper involve slowly varying effects only where time retardation is not needed. Time retardation does not necessarily alter the agreement with (or violation of) Newton's third law; as the time for an effect to travel from element d^3r' at \mathbf{r}' to element d^3r at \mathbf{r} equals the time for an effect to travel in the opposite direction from d^3r at \mathbf{r} to d^3r' at \mathbf{r}' . Thus for example, for the time harmonic case when source and detector are in phase (the case of interest here) Newton's third law can be satisfied. However, in general time retardation *does* imply an instantaneous violation of Newton's third law when only the source and the detector are considered. To satisfy Newton's third law instantaneously time retardation implies that inertial properties must be ascribed to the electromagnetic field itself.

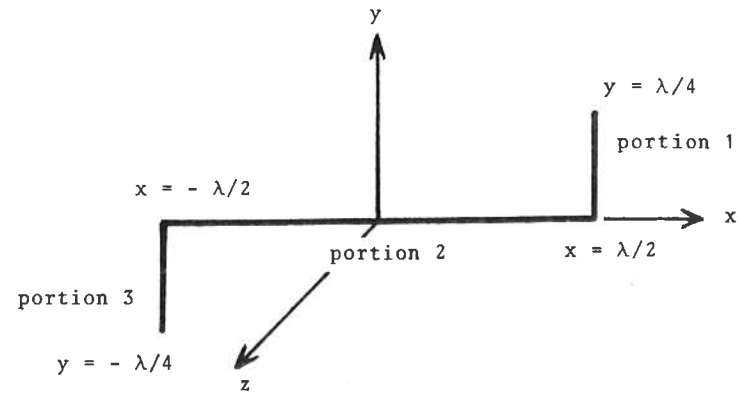

Figure 6. The Pappas-Vaughan Z-shaped antenna showing the choice of coordinates with the three portions of the antenna: portion 1 at $x = \lambda/2$ from $y = 0$ to $\lambda/4$, portion 2 at $y = 0$ from $x = -\lambda/2$ to $\lambda/2$, and portion 3 at $x = -\lambda/2$ from $y = 0$ to $y = -\lambda/4$.

6.1 Description of the Pappas-Vaughan antenna

The Pappas-Vaughan⁽³⁵⁾ Z-shaped antenna is shown in Fig. 6 with the three portions involved and the choice of coordinates. The antenna is suspended along the z axis. The current and charge densities induced by an air core transformer at the center are time harmonic with all portions of the antenna in phase; thus,

$$\mathbf{J}(\mathbf{r}, t) = \mathbf{J}(\mathbf{r}) \cos \omega t \quad \text{and} \quad \rho(\mathbf{r}, t) = \rho(\mathbf{r}) \sin \omega t, \quad (45)$$

where $\omega = 2\pi f$ is the angular frequency. To satisfy the equation of continuity for charge, $\nabla \cdot \mathbf{J} + \partial \rho / \partial t = 0$, the time harmonic variation for the charge is taken as $\sin \omega t$, when the time variation of the current is taken as $\cos \omega t$. The space part of the current density $\mathbf{J}(\mathbf{r})$ induced in the various portions of the antenna are

$$\begin{aligned} \mathbf{J}_1 &= \mathbf{e}_y I \cos ky \delta(x - \lambda/2) u(y) u(-y + \lambda/4), \\ \mathbf{J}_2 &= -\mathbf{e}_x I \cos kx u(x + \lambda/2) u(-x + \lambda/2) \delta(y), \\ \mathbf{J}_3 &= \mathbf{e}_y I \cos ky \delta(x + \lambda/2) u(-y) u(y + \lambda/4), \end{aligned} \quad (46)$$

where $\delta(x)$ is the delta function, $u(x)$ is the unit step function, zero for $x < 0$ and unity for $x \geq 0$, and I is the peak current. The space part of the charge density $\rho(\mathbf{r})$ induced on the various portions of the antenna are

$$\begin{aligned} c\rho_1 &= I \sin ky \delta(x - \lambda/2) u(y) u(-y + \lambda/4), \\ c\rho_2 &= -I \sin kx u(x + \lambda/2) u(-x + \lambda/2) \delta(y), \\ c\rho_3 &= I \sin ky \delta(x + \lambda/2) u(-y) u(y + \lambda/2). \end{aligned} \quad (47)$$

6.2 The net self-torque on the antenna due to forces obeying Newton's third law are zero

A force $\mathbf{F}(\mathbf{r}, \mathbf{r}')$ acting on an unprimed particle (or volume element $d^3\mathbf{r}$) at \mathbf{r} due to a primed particle (or volume element $d^3\mathbf{r}'$) at \mathbf{r}' that satisfies Newton's third law is of the form

$$\mathbf{F}(\mathbf{r}, \mathbf{r}') = (\mathbf{r} - \mathbf{r}')G(\mathbf{r}, \mathbf{r}') = -\mathbf{F}(\mathbf{r}', \mathbf{r}) = -(\mathbf{r}' - \mathbf{r})G(\mathbf{r}', \mathbf{r}), \quad (48)$$

where $G(\mathbf{r}, \mathbf{r}') = G(\mathbf{r}', \mathbf{r})$ is a function symmetric to an interchange of primed and unprimed coordinates, and $\mathbf{F}(\mathbf{r}', \mathbf{r})$ is the force acting on the primed particle (or volume element) at \mathbf{r}' due to the unprimed particle (or volume element) at \mathbf{r} . The torque $\mathbf{T}(\mathbf{r}, \mathbf{r}')$ about an axis, which may be taken as the z axis, produced by the force $\mathbf{F}(\mathbf{r}, \mathbf{r}')$ acting on the unprimed particle (or volume element) is given, using equation (48), by

$$\mathbf{T}(\mathbf{r}, \mathbf{r}') = \{\mathbf{s} \times \mathbf{F}(\mathbf{r}, \mathbf{r}')\} \cdot \mathbf{e}_z = \{x(y - y') - y(x - x')\}G(\mathbf{r}, \mathbf{r}'), \quad (49)$$

where

$$\mathbf{s} = x\mathbf{e}_x + y\mathbf{e}_y, \quad (50)$$

is the radial distance from the z axis, the lever arm, and \mathbf{e}_x , \mathbf{e}_y , and \mathbf{e}_z are unit vectors in the cartesian coordinate directions. The net self-torque on the system, the torque due to the force acting on the unprimed particle plus the torque due to the force acting on the primed particle, then becomes, using equations (48), (49), and (50),

$$\begin{aligned} \mathbf{T}(\mathbf{r}, \mathbf{r}') + \mathbf{T}(\mathbf{r}', \mathbf{r}) &= \{\mathbf{s} \times \mathbf{F}(\mathbf{r}, \mathbf{r}') + \mathbf{s}' \times \mathbf{F}(\mathbf{r}', \mathbf{r})\} \cdot \mathbf{e}_z \\ &= (yx' - xy')G(\mathbf{r}, \mathbf{r}') + (y'y - x'y)G(\mathbf{r}', \mathbf{r}) = 0. \end{aligned} \quad (51)$$

A summation over all particle pairs or an integration over both primed and unprimed volume elements then also yields zero.

6.3 Weber-Wesley theory predicts a zero self-torque on the Pappas-Vaughan antenna

Substituting Eqs. (45) into Eqs. (9) through (12), the Weber-Wesley force on an element of volume $d^3\mathbf{r}$ at \mathbf{r} due to a volume $d^3\mathbf{r}'$ at \mathbf{r}' may be obtained at any instant t . Experimentally only the time average force is of interest. Averaging over a cycle involves the integrals

$$\begin{aligned} \int_0^{2\pi/\omega} dt \sin \omega t \sin(\omega t - kR) &= (\cos kR)/2, \\ \int_0^{2\pi/\omega} dt \cos \omega t \cos(\omega t - kR) &= (\cos kR)/2, \end{aligned} \quad (52)$$

where $k = \omega/c = 2\pi/\lambda$ is the propagation constant.

Using this result (52) the time average force between volume elements from Eqs. (9) through (12), which is appropriate for the Pappas-Vaughan antenna, is given by

$$\begin{aligned} 2c^2 \langle d^6\mathbf{F}_W/d\mathbf{r}^3 d\mathbf{r}^3 \rangle &= \mathbf{R} \left\{ \left[c^2 \rho \rho' - 2\mathbf{J} \cdot \mathbf{J}' + 3(\mathbf{R} \cdot \mathbf{J})(\mathbf{R} \cdot \mathbf{J}')/R^2 + \omega \rho \mathbf{R} \cdot \mathbf{J}' \right. \right. \\ &\quad \left. \left. - \omega \rho' \mathbf{R} \cdot \mathbf{J} \right] Q(R) - k^2 \left[(\mathbf{R} \cdot \mathbf{J})(\mathbf{R} \cdot \mathbf{J}')/R^2 \right] P(R) \right\}, \end{aligned} \quad (53)$$

where ρ , ρ' , \mathbf{J} , and \mathbf{J}' refer here to only the space parts, Eqs. (46) and (47), and where

$$P(R) = (\cos kR)/R \quad \text{and} \quad Q(R) = (\cos kR + kR \sin kR)/R^3. \quad (54)$$

This time average result (53) is seen to satisfy Newton's third law; as it is directed along \mathbf{R} and interchanging primes and unprimes yields only a change of sign, the functions $P(R)$ and $Q(R)$ being invariant to an interchange of primes and unprimes. Considering the result of Section 6.2 above the Weber-Wesley theory predicts a zero self-torque on the Pappas-Vaughan antenna.

6.4 Integrals for the Maxwell-Lorentz self-torque on the Pappas-Vaughan antenna

Substituting the time harmonic variations specified by Eqs. (45) into Eqs. (23) and (10) and taking a time average over a cycle, using

Eqs. (52), the time average Maxwell-Lorentz force between volume elements becomes

$$2c^2 \langle d^6 \mathbf{F}_M / d^3 r d^3 r' \rangle = \omega \rho \mathbf{J}' P(R) + \left[c^2 \mathbf{R} \rho \rho' - \mathbf{R}(\mathbf{J} \cdot \mathbf{J}') + \mathbf{J}'(\mathbf{J} \cdot \mathbf{R}) \right] Q(R), \quad (55)$$

where $P(R)$ and $Q(R)$ are defined by Eqs. (54) and ρ, ρ', \mathbf{J} , and \mathbf{J}' refer to the space parts as given by Eqs. (46) and (47).

It may be seen that the second and third terms on the right of Eq. (55) satisfy Newton's third law. Considering Section 6.2, these terms will contribute nothing to the self-torque on the Pappas-Vaughan antenna. Only the first and fourth terms on the right of Eq. (55), violating Newton's third law, can contribute to a nonzero self-torque.

It is convenient to write the self-torque T as the sum of two terms: U the contribution from charge-current interactions given by the first term on the right of Eq. (55) and V the contribution from current-current interactions given by the fourth term on the right of Eq. (55); thus,

$$T = U + V, \quad (56)$$

where

$$\begin{aligned} U &= (\omega/2c^2) \iint d^3 r d^3 r' \rho \mathbf{e}_z \cdot (\mathbf{s} \times \mathbf{J}') P(R), \\ V &= (1/2c^2) \iint d^3 r d^3 r' \mathbf{e}_z \cdot (\mathbf{s} \times \mathbf{J}') Q(R), \end{aligned} \quad (57)$$

where the ρ 's and \mathbf{J} 's are given by Eqs. (46) and (47), \mathbf{s} is defined by Eq. (50), and $P(R)$ and $Q(R)$ are given by Eqs. (54).

The labor of evaluating the integrals in Eqs. (57) is considerably reduced by noting that the charge and current densities are all confined to the xy -plane; so \mathbf{J} has only x and y components; and the volume integrations reduce to integrations over $x, y, x',$ and y' . Equations (57) may be written as

$$\begin{aligned} U &= (\omega/2c^2) \iint dx dy dx' dy' \rho (xJ'_y - yJ'_x) P(R), \\ V &= (1/2c^2) \iint dx dy dx' dy' (xJ'_y - yJ'_x) \left[(x - x')J_x + (y - y')J_y \right] Q(R). \end{aligned} \quad (58)$$

The integrals (58) may be broken down in terms of contributions from the various portions of the antenna. Thus, U_{13} is the torque arising

from charge-current interactions due to portion 3 acting on portion 1, U_{21} is the torque due to portion 1 acting on portion 2, etc. From symmetry it may be seen that the torque involving portion 3 equals the torque involving portion 1. In particular, to evaluate the torque on portion 3 a mathematical rotation of the antenna through 180° may be made that brings portion 3 into the original position of portion 1. Only the signs of the charges and currents are reversed as compared with the original situation before the rotation. But since the integrals involve a product of two currents or a product of a charge density and a current density; the integrals remain precisely the same as before the rotation. The torque involving portion 3 must, therefore, be identical to that produced by portion 1. It is sufficient to merely double the contributions involving portion 1 to obtain the net torque. The contributions due to charge-current and current-current interactions may then be written as

$$U = 2U_{13} + 2U_{12} + 2U_{21} \quad (59)$$

$$V = 2V_{13} + 2V_{12} + 2V_{21}$$

Substituting Eqs. (46), (47), and (54) into the first of Eqs. (58) yields

$$\begin{aligned} 2U_{13} &= (\pi I^2/c^2) \int_0^{\lambda/4} dy \int_{-\lambda/4}^0 dy' \sin ky \cos ky' (\cos kR'/R') \\ 2U_{12} &= (kI^2/c^2) \int_{-\lambda/2}^{\lambda/2} dx \int_0^{\lambda/4} dy y \sin ky \cos kx (\cos kR/R), \\ 2U_{21} &= (-kI^2/c^2) \int_{-\lambda/2}^{\lambda/2} dx \int_0^{\lambda/4} dy x \sin kx \cos ky (\cos kR/R), \end{aligned} \quad (60)$$

where here

$$R'^2 = \lambda^2 + (y - y')^2 \quad \text{and} \quad R^2 = (x - \lambda/2)^2 + y^2. \quad (61)$$

Similarly substituting Eqs. (46), (47), and (54) into the second of Eqs. (58) yields

$$\begin{aligned}
ZV_{13} &= (I^2 \lambda / 2c^2) \int_0^{\lambda/4} dy \int_{-\lambda/4}^0 dy' (y - y') \cos ky \cos ky' Q(R'), \\
ZV_{12} &= (I^2 / c^2) \int_{-\lambda/2}^{\lambda/2} dx \int_0^{\lambda/4} dy y^2 \cos kx \cos ky Q(R), \\
ZV_{21} &= (-I^2 / c^2) \int_{-\lambda/2}^{\lambda/2} dx \int_0^{\lambda/4} dy x(x - \lambda/2) \cos kx \cos ky Q(R),
\end{aligned} \tag{62}$$

where R' and R are given by Eqs. (61) and $Q(R)$ is defined by the second of Eqs. (54).

6.5 Evaluation of the Maxwell-Lorentz integrals for the self-torque on the Pappas-Vaughan antenna

The net Maxwell-Lorentz self-torque on the Pappas-Vaughan antenna given by Eq. (56) involves the integration of the integrals found in Eqs. (60) and (62). It may be noted from the definition of $Q(R)$, Eq. (54), and Eqs. (61) that

$$\begin{aligned}
(y - y')Q(R') &= -\partial/\partial y (\cos kR'/R'), \\
yQ(R) &= -\partial/\partial y (\cos kR/R), \\
(x - \lambda/2)Q(R) &= -\partial/\partial x (\cos kR/R).
\end{aligned} \tag{63}$$

Using this result (63), the integrals in equations (62) may be integrated by parts yielding

$$\begin{aligned}
ZV_{13} &= (I^2 \lambda / 2c^2) \int_{-\lambda/4}^0 dy' \cos ky' \left\{ -\cos ky (\cos kR'/R') \right\} \Big|_{y=0}^{y=\lambda/4} \\
&\quad - k \int_0^{\lambda/4} dy \sin ky (\cos kR'/R') \Big\} \\
ZV_{12} &= (I^2 / c^2) \int_{-\lambda/2}^{\lambda/2} dx \cos kx \left\{ -y \cos ky (\cos kR/R) \right\} \Big|_{y=0}^{y=\lambda/4} \\
&\quad + \int_0^{\lambda/4} dy (\cos ky - ky \sin ky) (\cos kR/R) \Big\}
\end{aligned} \tag{64}$$

$$\begin{aligned}
ZV_{21} &= (I^2 / c^2) \int_0^{\lambda/4} dy \cos ky \left\{ x \cos kx (\cos kR/R) \right\} \Big|_{x=-\lambda/2}^{x=\lambda/2} \\
&\quad - \int_{-\lambda/2}^{\lambda/2} dx (\cos kx - kx \sin kx) (\cos kR/R) \Big\}.
\end{aligned}$$

It may be seen that the last term on the right of the first of Eqs. (64) equals $-2U_{13}$, as given by the first of Eqs. (60); the last term on the right of the second of Eqs. (64) equals $-2U_{12}$, as given by the second of Eqs. (60); and the last term on the right of the third of Eqs. (64) equals $-2U_{21}$, as given by the third of Eqs. (60). Moreover, it may be seen that the second term on the right of the second of Eqs. (64) equals minus the second term on the right of the third of Eqs. (64). Combining terms for the total self-torque, using Eqs. (56), (59), (60), and (64), therefore, yields only the sum of the first terms appearing on the right of the three Eqs. (64), which involve only single integrations. Putting in the limits of integration arising from the first integrations and adding the resulting single integration terms in Eq. (26) yields the net time average Maxwell-Lorentz self-torque on the Pappas-Vaughan antenna as

$$T = (-I^2 \lambda / 2c^2) \int_0^{\lambda/4} dy (\cos^2 ky) / y. \tag{65}$$

This result (65), which arises primarily from the corners of the antenna, predicts an infinite Maxwell-Lorentz self-torque on the Pappas-Vaughan antenna, there being a logarithmic singularity as $y \rightarrow 0$. The infinity arises from the fact that the current densities were assumed to be infinite, a finite current being confined to wires of infinitesimal cross sections. If the wires are assumed to be of finite cross section and to be bent around small curves instead of forming sharp corners, the integral in Eq. (65) can be replaced by a rough realistic estimate by letting $y \geq b$, where b is a small nonzero parameter. In particular, for the Pappas-Vaughan setup b may be taken as roughly equal to $\lambda/100$ (which is about 1 cm for the antenna actually used). Thus,

$$\int_0^{\lambda/4} dy \cos^2 ky / y \rightarrow \int_{\lambda/100}^{\lambda/4} dy \cos^2 ky / y \approx \int_{\lambda/100}^{\lambda/4} dy (1/2) / y = 1.610; \tag{66}$$

6.6 Discussion and conclusions concerning the self-torque on the Pappas-Vaughan antenna

Pappas and Vaughan⁽³⁵⁾ found from the power fed to their antenna of at least 35 watts and its impedance of 70 ohms that the peak current was at least 1 ampere. Substituting this value into Eqs. (65) and (66), where $\lambda = 2\text{m}$, yields the estimate of the self-torque on the Pappas-Vaughan antenna predicted by the Maxwell-Lorentz theory of at least

$$T \sim -0.805 I^2 \lambda / c^2 > -10^{-2} \text{ Nt m.} \quad (67)$$

This is 5 orders of magnitude greater than the minimum torque of 10^{-7} Nt m that could have been observed.

As an experimental check they had no difficulty in obtaining a strong deflection when a half-wavelength straight wire was brought into the neighborhood of one end of their antenna. The dipole induced in the wire by their antenna would be expected to produce an effect of the same order of magnitude, but smaller, than that predicted by the Maxwell-Lorentz theory.

It is concluded that the nonzero self-torque predicted by the Maxwell-Lorentz theory does not agree at all with the experimental result of Pappas and Vaughan; while the zero torque predicted by the Weber-Wesley theory and Newton's third law does agree with their result to within the limits of the sensitivity of their setup.

7. WEBER THEORY OF UNIPOLAR INDUCTION AND THE EXPERIMENTS OF MÜLLER AND KENNARD

Much confusion exists today concerning unipolar induction, because the traditional theories of Faraday and Maxwell cannot give unequivocal answers. These theories also do not agree with the important experimental results of Müller⁽³⁶⁾ and Kennard.⁽³⁷⁾ In contrast, the Weber theory, based upon the interaction between point charges, yields unequivocal agreement with all of the experimental results.

It is frequently attempted to use Maxwell's flux rule, Eq. (29), for all induction phenomena; but this type of induction is limited to the case of a *changing* magnetic flux through a closed loop produced by closed current loop sources. The more general Weber theory predicts

induction where no magnetic flux can be defined and no closed current loops at all need be involved. For example, unipolar induction involves no change of magnetic flux (which remains zero) through the loop in which current is induced, as recognized by Cohn,⁽³⁸⁾ Culliwick,⁽³⁹⁾ and Feynman⁽⁴⁰⁾ (Although others, such as Savage,⁽⁴¹⁾ Panofsky and Phillips,⁽⁴²⁾ and Scanlon et al,⁽⁴³⁾ try to see a change in flux.). The Maxwell flux rule, involving the net flux through a closed loop, either assumes that the induced emf occurs uniformly around the loop; or else it fails to predict where the seat of the emf might be in the closed loop. The experiment of Müller⁽³⁶⁾ reveals the fact that the seat of emf can be localized and just where in a closed loop it can occur.

Faraday⁽⁴⁴⁾ performed his famous rotating disk experiment in 1832. A copper disk is rotated near the pole of a magnet. Stationary wires touch the center and rim of the disk through sliding contacts, as shown in Fig. 7. This produces an emf, which can be detected by inserting a volt meter in the circuit.

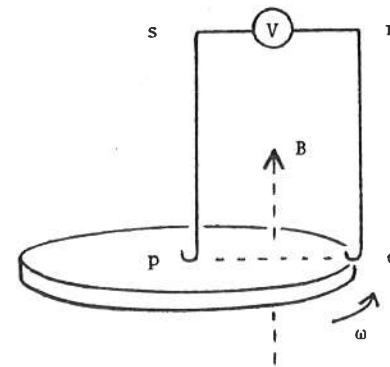

Fig. 7. Faraday's rotating disk experiment. The magnetic field B is perpendicular to the disk. The induced emf is registered on the volt meter.

Faraday attributed this "motional" emf to the disk "cutting" magnetic field lines, the induced electric field at a point in the disk being given by

$$c\mathbf{E} = \mathbf{v} \times \mathbf{B}, \quad (68)$$

where \mathbf{v} is the velocity of the disk and \mathbf{B} is the magnetic field at the point in question. Faraday originally assumed that the magnetic field lines were rigidly fixed to the magnet; and, thus, relative motion between the disk and the source of the magnetic field was needed to generate an emf. This is a view still found in most textbooks and held by many physicists such as Trocheris⁽⁴⁵⁾ and Cullwick.⁽³⁹⁾ But it is not true. When the magnet is rotated with the disk, precisely the same emf is induced, as soon discovered by Faraday himself. Faraday then changed his mind: He decided that the magnetic field lines remained fixed in space; even though the magnet itself rotated. In this way the "cutting" hypothesis could still work. In 1851 Faraday⁽⁴⁶⁾ again changed his mind: He decided that the magnetic field lines did, in fact, rotate with the magnet after all. The "moving" magnetic field lines, "cutting" the stationary external circuit rs in Fig. 7, generated the observed emf. Cullwick⁽³⁹⁾ agrees with this view of Faraday. He says that the emf occurs in that wire which is in motion relative to the magnet. This conclusion is not supported by Müller's experiment nor Weber's theory.

7.1 Weber's theory of unipolar induction

Induction involves the force on the mobile electrons - q_e in the detector conductor. For unipolar induction the electrons in the detector have only the velocity of the detector \mathbf{v}_i (conduction currents in the detector are not considered). For unipolar induction only steady current sources are involved where $d\mathbf{v}'_e/dt = 0$. The net force on the detector electrons is then the sum of the force due to the source ions q'_i moving with a velocity \mathbf{v}'_i , the velocity of the source conductor, plus the force due to the source electrons - q'_e moving with a velocity $\mathbf{v}'_e + \mathbf{v}'_i$, where \mathbf{v}'_e is the steady electron velocity relative to the source conductor. For the case of the source carrying no net charge, $q'_i = q'_e$, Eq. (4) yields the Weber force on the detector electrons as

$$c^2\mathbf{F}_W = (q_e q'_e R/R^3) \left[-2\mathbf{v}_i \cdot \mathbf{v}'_e + 3(\mathbf{R} \cdot \mathbf{v}_i)(\mathbf{R} \cdot \mathbf{v}'_e)/R^2 + v_e'^2 + 2\mathbf{v}'_e \cdot \mathbf{v}'_i \right. \\ \left. - 3(\mathbf{R} \cdot \mathbf{v}'_e)(\mathbf{R} \cdot \mathbf{v}'_i)/R^2 - 3(\mathbf{R} \cdot \mathbf{v}'_e)^2/2R^2 \right]. \quad (69)$$

The last four terms on the right of Eq. (69) involve the force due to velocity squared currents on a static charge. Such effects cannot be observed as they are exactly cancelled inside the source conductor itself by an induced static charge distribution as explained in Section 1.3 above. The observable unipolar induction between point charges then becomes

$$c^2\mathbf{F}_W = (q_e q'_e R/R^3) \left\{ -2\mathbf{v}_i \cdot \mathbf{v}'_e + 3(\mathbf{R} \cdot \mathbf{v}_i)(\mathbf{R} \cdot \mathbf{v}'_e)/R^2 \right\}. \quad (70)$$

An interesting feature of this result (70) is that the motion of the source conductor \mathbf{v}'_i does not enter in. Only the velocity of the source electrons relative to the source conductor \mathbf{v}'_e is involved. It may be noted that moving a current carrying wire parallel to itself with the velocity \mathbf{v}'_i does not change the net current in the wire, the electron current - $q'_e(\mathbf{v}'_e + \mathbf{v}'_i)$ plus the ion current $q'_i \mathbf{v}'_i$ yielding - $q'_e \mathbf{v}'_e$ when $q'_e = q'_i$.

When *extended* sources are moved with a velocity \mathbf{v}'_i an additional effect, a "pseudo-effect", occurs, which yields the appearance of a time rate of change of current or accelerating charges due to a variation in the electromagnetic field at the detector with time. This force per unit charge is given by

$$- (\mathbf{v}'_i \cdot \nabla)(\mathbf{A} - \nabla\Gamma). \quad (71)$$

It vanishes for point charges. For extended sources this result (71) must be added to Eq. (70) for the unipolar induced force per unit charge given in terms of electromagnetic fields; thus,

$$c\mathbf{E}(\text{induction}) = \mathbf{v}_i \times (\nabla \times \mathbf{A}) - \mathbf{v}_i \cdot \nabla \cdot \mathbf{A} + (\mathbf{v}_i \cdot \nabla) \nabla \Gamma \\ - (\mathbf{v}'_i \cdot \nabla)(\mathbf{A} - \nabla\Gamma). \quad (72)$$

This Weber-Wesley result (72) can predict the induced electric field in a detector for many possible situations; but the experiments of interest here require only the Maxwell case of closed current loop

sources where $\nabla \cdot \mathbf{A} = \Gamma = 0$. In addition, in these experiments the motion of the source \mathbf{v}' is confined to situations where $-(\mathbf{v}' \cdot \nabla) \mathbf{A} = 0$. For the experimental situations of interest here the unipolar induction then reduces to

$$c\mathbf{E} = \mathbf{v} \times (\nabla \times \mathbf{A}). \quad (73)$$

Using the fact that $\mathbf{B} = \nabla \times \mathbf{A}$, Eq. (73) yields the original Faraday result (68). It might, thus, seem that the Weber-Wesley theory offers nothing more than the Faraday theory; but this is not true. The derivation of Eq. (68) from the Weber-Wesley theory now makes the meaning of the magnetic field clear. The interpretation of the magnetic field by Faraday and Maxwell as physically tangible rigid lines of force attached to a source is seen to be physically untenable. The \mathbf{B} field, like the vector potential \mathbf{A} , is merely a mathematical artifact, a mathematical device, of no particular direct physical significance, used to help solve the problem of how moving point source charges affect moving point detector charges.

To make it abundantly clear that magnetic field lines can never "move" to "cut" a stationary wire, it may be noted from Eq. (70) and (73) that the induced electric field is *entirely independent* of the state of rotational motion of the source solenoid (or permanent magnet) about the axis of the solenoid. Rotating the solenoid merely moves the wires of the solenoid parallel to themselves; so, as explained above following Eq. (70), the net current in the solenoid remains the same.

The question remains: What is the frame of reference in which the velocity \mathbf{v}_i is to be measured? It is not to be measured with respect to the current electrons in the source solenoid nor with respect to the moving solenoid itself. Experimentally the velocity \mathbf{v}_i is measured with respect to the laboratory. When the disk is stationary in the laboratory no induced electric field is observed.

It may be seen that Eq. (70), which yields the induction formula (73), arises from the cross product terms of the squares of *relative* velocities: $(\mathbf{v}_i - \mathbf{v}'_e - \mathbf{v}'_i)^2$, $(\mathbf{R} \cdot (\mathbf{v}_i - \mathbf{v}'_e - \mathbf{v}'_i))^2$, $(\mathbf{v}_i - \mathbf{v}'_i)^2$, and $(\mathbf{R} \cdot (\mathbf{v}_i - \mathbf{v}'_i))^2$. The squared terms drop out as unobservable leaving only the cross product terms $2\mathbf{v}_i \cdot \mathbf{v}'_e$ and $2(\mathbf{R} \cdot \mathbf{v}_i)(\mathbf{R} \cdot \mathbf{v}'_e)$. Thus, the Weber theory starts out using

only *relative* velocities to derive a result which has only an *absolute* velocity (The reference frame is experimentally the laboratory). The same thing happens in deriving Ampere's law, Eq. (6). The cross product terms yield a result in which source and detector electron velocities become independently prescribed. In both cases the systems involved may be still *implicitly* physically determined by the velocity squared terms whose effect has been dropped as not observable.

7.2 Unipolar induction experiments of Kennard and Müller

Kennard⁽³⁷⁾ eliminated the circuit pqrs, as shown in Fig. 7. No current flow was involved. He measured directly the static voltage difference induced across pq. There was then no doubt that the seat of the emf was across pq. Since the static voltage difference is extremely small; the effect was enhanced by introducing a capacitor across pq. The capacitor consisted of two concentric cylinders. They were connected by a radial wire which functioned like the radius pq of the Faraday disk. The magnetic field was not produced by a permanent magnet but by a concentric solenoid outside the capacitor. The solenoid was free to rotate independently. With this setup Kennard observed the following: 1) A voltage difference was induced when the radial wire together with the capacitor were rotated and the current carrying solenoid was stationary. 2) No voltage was induced when the solenoid was rotated and the radial wire with capacitor were stationary. And 3) the same voltage difference as in case 1) above was generated when the radial wire, capacitor, and solenoid were all rotated together at the same rate as in case 1). Kennard, thus, demonstrated that unipolar induction occurred when there was no relative motion what-so-ever between any portions of the apparatus. The induced voltage depended in this case only upon the *absolute* rotational velocity with respect to the laboratory of the whole apparatus as a unit. More precisely, in agreement with the Weber theory above, the induced voltage was only a function of the rotational velocity with respect to the laboratory of the radial wire with capacitor and was independent of the rate of rotation of the solenoid. Kennard's result clearly shows that magnetic field lines do not rotate with the solenoid as assumed by Faraday in 1851.

Müller⁽³⁶⁾ obtained the same results as Kennard using a permanent magnet and the setup shown in Fig. 8. In addition, Müller was able to

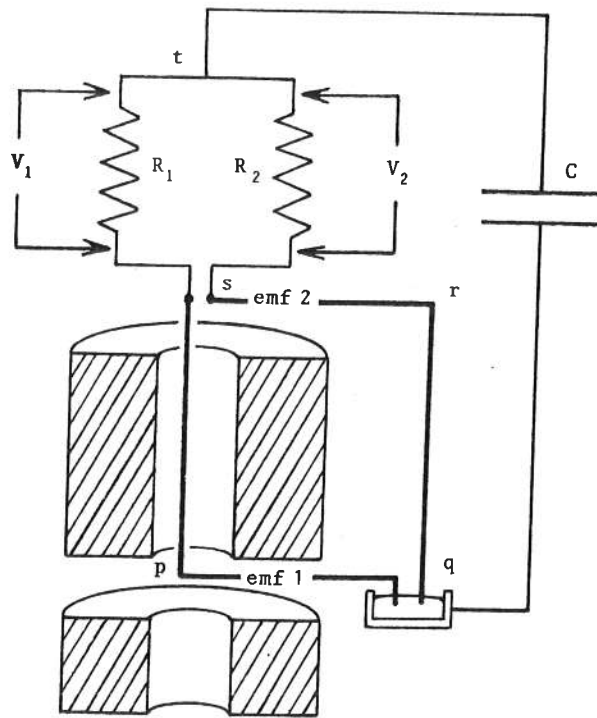

Figure 8. Diagram of the Müller experiment to determine the seat of unipolar induction using an annular shaped permanent magnet with a gap as shown. Portions pq and rs of the circuit and the magnet can be oscillated rotationally back and forth independently. An oscillating voltage V_1 across R_1 indicates an emf 1 induced in the portion pq, and an oscillating voltage V_2 across R_2 indicates an emf 2 induced in the portion rs.

localize the seat of the emf. Like Kennard, Müller replaced Faraday's disk with a straight wire pq. Instead of having the equipment perform complete rotations, Müller simply oscillated the various portions of his setup back and forth. The portion pq, the portion rs, and the magnet could be oscillated independently.

Considering Fig. 8, if portion pq is oscillated rotationally back and forth rapidly in comparison to the RC decay time of the circuit, while the portion rs is held stationary, an emf 1 will be induced across pq and none will be induced across rs. This will cause an oscillating voltage V_1 to appear across R_1 and essentially no voltage signal across R_2 . When rs is rotated while pq remains stationary a signal V_2 will appear across R_2 and essentially no signal across R_1 indicating an emf is induced in rs and none in pq. In this way he was able to distinguish in which branch of the circuit pqrst or qrstp an emf arose. The seat of the emf in the closed loop pqrstp could, thus, be localized.

To eliminate the possibility that when the magnet is oscillated "moving" magnetic field lines might also induce an emf in the capacitor branch of the circuit giving spurious results the experiment was also performed using an iron yoke around the magnet extending outward and inward to the plane of Fig. 8. With the yoke most of the magnetic field remains in the yoke; and the wire qrs and capacitor branch of the circuit were shielded from the magnetic field. With the yoke no magnetic field existed in the capacitor branch; and no emf could possibly be induced in the branch.

The experimental results are summarized in Table 2. The symbol - signifies no angular oscillation and the symbol ω signifies an angular oscillation, where, if two or more portions were oscillated at the same time, they were mechanically coupled together to oscillate as a unit. The symbol + means an emf was observed and the symbol 0 means that no emf was observed. For the cases 5 and 8 no signal was observed, as the emf's in pq and in rs, being the same, acted like two batteries back to back, which prohibited any current from flowing and any voltage from being registered.

Table 2. Seat of the unipolar emf induced for different cases

case	oscillating			no yoke		with yoke	
	magnet	wire pq	wire rs	emf pq	emf rs	emf pq	emf rs
1	-	-	-	0	0	0	0
2	-	-	ω	0	+	0	0
3	-	ω	-	+	0	+	0
4	ω	-	-	0	0	0	0
5	-	ω	ω	cancelled		+	0
6	ω	-	ω	0	+	0	0
7	ω	ω	-	+	0	+	0
8	ω	ω	ω	cancelled		+	0

7.3 Discussion and conclusions concerning unipolar induction

The experimental results of Kennard and those of Müller, as summarized in Table 2, agree in all particulars with the Weber-Wesley theory. Their results do not agree in all particulars with the theories of Maxwell and Faraday.

The Maxwell flux rule does not work; as the amount of flux through the loop pqrstp remains zero for all cases; and the emf is localized and not uniformly distributed around the whole loop.

The fact that unipolar induction depends solely upon the *absolute* (or laboratory) rotational velocity of the detector and does not depend at all upon the rotational velocity of the source of the magnetic field contradicts the usual traditional Faraday theory that induction arises only by virtue of the *relative* rotational motion of the source and the detector.

8. WEBER THEORY PREDICTS THE RESULT OF KAUFMANN'S EXPERIMENT

Assis⁽⁵²⁾ has shown that the Weber theory predicts the result of the Kaufmann⁽⁵³⁾ experiment (which has been repeated by Bucherer⁽⁵⁴⁾ and others,⁽⁵⁵⁾⁻⁽⁶¹⁾ as reviewed by Faragó and Jánosy⁽⁶²⁾). The experiment involves high velocity electrons. Kaufmann used a natural radioactive β -source. The electrons are passed between the plates of a condenser with an electric field and simultaneously a perpendicular magnetic field. In order for the electrons to pass between the plates

the electric and magnetic forces must cancel each other. After passing out of the condenser only the magnetic field acts. From the electric and magnetic fields and the radius of curvature when the magnetic field acts alone the ratio e/m can be measured as a function of the presumed velocity of the electrons.

The force on an electron moving between two infinite condenser plates with a uniform surface charge density $-\sigma$ at $z' = +z_0/2$ and $+\sigma$ at $z' = -z_0/2$ may be obtained from Eq. (4) for the case of a charge $q = e$ on the z -axis, $x = y = 0$, moving with the velocity \mathbf{v} and acceleration \mathbf{a} ; thus,

$$c^2 d^2 \mathbf{F} = (\sigma e dx' dy') (\mathbf{G}_+ - \mathbf{G}_-), \quad (74)$$

where

$$\mathbf{G}_\pm = (\mathbf{R}_\pm / R_\pm^3) [c^2 + v^2 - 3(\mathbf{v} \cdot \mathbf{R}_\pm)^2 / 2R_\pm^2 + \mathbf{R}_\pm \cdot \mathbf{a}], \quad (75)$$

and

$$\mathbf{R}_\pm = x'\mathbf{i} + y'\mathbf{j} + (z \pm z_0/2)\mathbf{k}, \quad (76)$$

where \mathbf{i} , \mathbf{j} , and \mathbf{k} are unit vectors in the cartesian coordinate directions. Substituting Eqs. (75) and (76) into (74) and integrating over the infinite x', y' -plane yields the force on the electron predicted by the Weber theory as

$$\mathbf{F}_z = eE(1 + v^2/2c^2 + za_z/c^2) \quad \text{and} \quad \mathbf{F}_r = -eE(\mathbf{v}_z \mathbf{v}_r + \mathbf{z} \mathbf{a}_r)/c^2, \quad (77)$$

where \mathbf{v}_z is the velocity component perpendicular to the condenser plates and \mathbf{v}_r is the velocity component parallel to the condenser plates, where $v^2 = v_z^2 + v_r^2$. a_z and \mathbf{a}_r are acceleration components perpendicular and parallel to the condenser plates, and $E = 4\pi\sigma$. This result agrees with Assis' result, his Eq. (3).

The force on the electron due to the simultaneous transverse magnetic field \mathbf{B} is given by the usual Lorentz expression; since the source of the steady magnetic field \mathbf{B} are closed current loops and the general Weber theory reduces to the special Maxwell case. When the electric and magnetic forces cancel each other, then Eq. (77) gives

$$eE(1 + v^2/2c^2) = evB/c, \quad (78)$$

where $E = 4\pi\sigma$ is the electric field for a zero velocity charge.

Outside of the condenser the electron moves in a circular path of

of radius r such that the magnetic force is balanced by the Newtonian centrifugal force; or

$$m_0 v^2 / r = evB/c. \quad (79)$$

Combining Eqs. (78) and (79) then yields the result

$$erB^2/c^2 E = m_0 (1 + E^2/2B^2 + E^4/2B^4), \quad (80)$$

to order E^4/B^4 .

This result (80) may be compared with the result obtained when Maxwell electrodynamics and mass change with velocity are assumed. Summarizing the equations for this case,

$$eE = evB/c = m_0 \gamma v^2 / r, \quad (81)$$

where

$$\gamma = 1/\sqrt{1 - v^2/c^2} = 1 + v^2/2c^2 + 3v^4/8c^4 + \dots \quad (82)$$

Combining Eqs. (81) and (82) yields the result

$$erB^2/c^2 E = m_0 (1 + E^2/2B^2 + 3E^4/8B^4 + \dots). \quad (83)$$

Comparing Eqs. (80) and (83), it is seen that they are identical to order E^2/B^2 and that they differ in the 4th power term E^4/B^4 , the Weber theory giving a coefficient of 1/2 and the Maxwell plus mass-change with velocity theory giving a coefficient of 3/8.

To compare these results with the literature⁽⁵³⁾⁻⁽⁶²⁾ it is necessary to convert Eqs. (80) and (83) into the language of a presumed "mass" m and a presumed "velocity" v . The Kaufmann experiment does not actually measure the electron velocity nor the electron mass directly. The "mass" m and "velocity" v reported in the literature are merely quantities inferred from the data for E , B , and r and the theory. As seen above the Maxwell theory, Eq. (80), and the Weber theory, Eq. (78), predict two different velocities. To compare with the literature Eqs. (80) and (83) may be converted to the "velocity" v and "mass" m defined in the literature, namely,

$$v/c = E/B \quad \text{and} \quad m = erB^2/c^2 E. \quad (84)$$

The results to be compared are then to order v^4/c^4 from Eq. (80) for the Weber theory

$$m = m_0 (1 + v^2/2c^2 + v^4/2c^4), \quad (85)$$

and from Eq. (83) for the Maxwell plus mass change with velocity theory

$$m = m_0 (1 + v^2/2c^2 + 3v^4/8c^4). \quad (86)$$

The experiments of the Kaufmann type⁽⁵³⁾⁻⁽⁶²⁾ have only been able to confirm the coefficient 1/2 of the first term varying as E^2/B^2 in Eq. (80) or v^2/c^2 in Eq. (85) to any reasonable degree of accuracy. The coefficients of E^4/B^4 or v^4/c^4 and higher order terms remain essentially unknown. Unfortunately it is often erroneously assumed that, since accelerators deliver particles with velocities greater than 0.9c, that the coefficients of E^4/B^4 and higher order terms must be accurately known experimentally. The reason the accuracy is so limited is that coefficients of the expansion Eq. (80) or (85) must be deduced from the derivatives of a scatter plot of the data for m/m_0 as a function of v^2/c^2 , the derivative yielding the coefficient of v^2/c^2 , the second derivative yielding the coefficient of v^4/c^4 , etc. The accuracy is, therefore, not so much determined by the magnitude of the parameter v^2/c^2 , but by the scatter of the data. The scatter increases as m/m_0 increases. The error in the coefficient 1/2 of the first term varying as v^2/c^2 is undoubtedly greater than 20 percent for the original Kaufmann⁽⁵³⁾ and Bucherer⁽⁵⁴⁾ experiments. The error in the coefficient for the better experiments today is still probably greater than about 5 percent.⁽⁶²⁾

It is concluded that Weber electrodynamics predicts as a natural consequence of the theory without any need to postulate an ad hoc mass change with velocity the result of the Kaufmann experiment to within the experimental error.

9. WEBER THEORY FOR THE HYDROGEN ATOM

The old Bohr model of the hydrogen atom assumes circular orbits of the negative charged electron, $-e$, about the positive charged nucleus, $+Ze$, of atomic number Z . For circular orbits where $dR/dt = 0$ the Weber potential, Eq. (1), reduces to the Coulomb potential. The Weber theory is compatible with the old Bohr hydrogen atom theory. Quantizing the angular momentum in the usual way,

$$mrv = n\hbar, \quad (87)$$

where m is the reduced electron-nucleus mass, r is the relative separation, v is the relative velocity, and \hbar is Planck's constant, the hydrogen atom is found to exist in discrete energy states E given by

$$E_n = -mZ^2e^4/2\hbar^2n^2, \quad (88)$$

where n is an integer, the total quantum number.

Weber electrodynamics, being based upon a potential, Eq. (1) or (2), is the only electrodynamic theory ever proposed that conserves energy for an isolated system of moving charges. The Weber theory predicts a stable nonradiating hydrogen atom. In contrast, the Maxwell theory says the electron in the Bohr model should radiate and spiral into the nucleus.

When circular orbits are not assumed then the radial separation rate dR/dt in the Weber potential, Eq. (1) enters in to affect the energy levels predicted. Each of the energy levels of the Bohr model, Eq. (88), becomes split into a number of discrete levels clustered very near the original Bohr level. The accurate Schroedinger quantum theory is needed here. Since only small deviations from the Coulomb potential are produced by the velocity dependent part of the Weber potential; the usual approximate technique, the Schroedinger perturbation method, may be used to obtain the energy levels deviating from the Bohr levels.

The Weber potential for the hydrogen atom from Eq. (1) becomes

$$V = -(Ze^2/r)(1 - \dot{r}^2/2c^2), \quad (89)$$

where r is the separation distance and \dot{r} is the radial velocity. Solving the classical mechanics problem, the two integrals of the motion for the angular momentum L and the total energy E_t are

$$m\dot{r}^2\dot{\phi} = L, \quad - (Ze^2/r)(1 - \dot{r}^2/2c^2) + m(\dot{r}^2 + r^2\dot{\phi}^2)/2 = E_t, \quad (90)$$

where E_t is the total energy and where the motion is confined to the $r\phi$ -plane. From Eqs. (90) eliminating $\dot{\phi}$, the total energy becomes

$$E_t = (m\dot{r}^2/2)(1 + Ze^2/mc^2r) + L^2/2mr - Ze^2/r. \quad (91)$$

Since the rest energy mc^2 is much larger than the Coulomb energy Ze^2/r ; to a first approximation in powers of Ze^2/mc^2r the zeroth approximation of $m\dot{r}^2/2$ may be introduced, where

$$(m\dot{r}^2/2)_0 = E + Ze^2/r - L^2/2mr^2, \quad (92)$$

where E is the zeroth approximation for the total energy given by Eq. (88). Introducing Eq. (92) into Eq. (91) the total energy becomes to a first approximation in Ze^2/mc^2r

$$E_t = E + \Delta E, \quad (93)$$

where the perturbation energy ΔE is given by

$$\Delta E = (E + Ze^2/r - L^2/2mr^2)(Ze^2/mc^2r). \quad (94)$$

Using the usual Schroedinger perturbation method Eq. (94) may be approximated by

$$\Delta E = (Ze^2|E|/mc^2)\langle r^{-1} \rangle - (Z^2e^4/mc^2)\langle r^{-2} \rangle + (Ze^2L^2/2m^2c^2)\langle r^{-3} \rangle, \quad (95)$$

where the expectation values are given by

$$\langle r^{-j} \rangle = \int_0^\infty R_{n\ell}^2 r^{-j} r^2 dr, \quad (96)$$

where $R_{n\ell}$ are the usual normalized radial wave functions for the hydrogen atom, n is the total quantum number, and ℓ is the azimuthal quantum number. As is well known, the angular momentum L is quantized such that

$$L^2 = \hbar^2 \ell(\ell + 1), \quad (97)$$

as in the unperturbed case. It may be shown (see Pauling and Wilson⁽⁶³⁾) that Eq. (96) yields

$$\begin{aligned} \langle r^{-1} \rangle &= Z/a_0 n^2, \\ \langle r^{-2} \rangle &= Z^2/a_0^2 n^3 (\ell + 1/2), \\ \langle r^{-3} \rangle &= Z^3/a_0^3 n^3 \ell(\ell + 1)(\ell + 1/2), \end{aligned} \quad (98)$$

where the first Bohr radius a_0 is given by

$$a_0 = \hbar^2/mc^2. \quad (99)$$

Substituting Eqs. (98) and (99) into (95) yields the perturbation energy $\Delta E_{n\ell}$ due to the velocity squared term in the Weber potential; thus,

$$\Delta E_{n\ell} = (2E_n^2/mc^2) \left[1 - n/(\ell + 1/2) \right], \quad (100)$$

where E_n is given by Eq. (88).

This result (100) agrees with the observations of the fine structure splitting of the hydrogen spectrum. To obtain the total multiplicity of lines observed the spin and magnetic moment of the electron must also be included. The matter is taken no further here.

It may be noted that the first term in the square bracket on the right of Eq. (100) is 1 instead of 3/4 as given when the Maxwell theory and mass change with velocity are assumed. The difference cannot be detected; as the separation between the values of E_n for different values of n is so much larger than the very small shift, or perturbation, of the "center" of the fine-structure pattern. Thus, $|E|(1 + 2|E|/mc^2)$ cannot be distinguished from $|E|(1 + 3|E|/2mc^2)$.

In conclusion it is seen that the fine structure splitting of the Bohr energy levels is given as a natural consequence of Weber electrodynamics without it being necessary to assume an ad hoc mass change with velocity.

10. CONCERNING THE POSSIBILITY OF MASS CHANGE WITH VELOCITY

The evidence usually cited⁽⁶²⁾ for mass change with velocity is the Kaufmann experiment and the fine structure energy levels of the hydrogen atom. In the foregoing Sections 8 and 9 it is shown that these results are better explained as a natural consequence of the firmly empirically established Weber electrodynamics without any ad hoc mass change with velocity being necessary. The usual evidence cited for mass change with velocity is, thus, no longer sufficient. The question then arises: Does mass really change with velocity? Is there any other empirical evidence that might support mass change with velocity?

The author⁽⁶⁵⁾ has shown that the correct frequency and propagation constant for the Voigt-Doppler effect, Eqs. (13), which explain the Michelson-Morley null result, can be derived by considering the emission and absorption of a photon of energy $\hbar\omega$ and momentum $\hbar\omega c/c^2$ with a massive body of energy $M_0 \gamma c^2$ and momentum $M_0 \gamma \mathbf{v}$. This would seem to support mass change with velocity $M = M_0 \gamma$. Unfortunately, the Voigt relations (incorrectly called the "Lorentz transformation") are not unique. Any power of γ can multiply the relations and still yield the

Voigt-Doppler effect and, thus, a null Michelson-Morley result. Thus, no unique momentum or energy for a body with nonzero mass is implied by the Voigt-Doppler effect; and it can yield no indirect evidence for mass change with velocity.

It might be thought that the principle of mass-energy equivalence, $E = mc^2$, might somehow imply mass change with velocity. Unfortunately, many types of energy can be defined. If a mass is to be associated with each of these types of energy, mass-energy equivalence becomes a tautology with no predictive value beyond the usual conservation of energy. The principle of mass-energy equivalence does not per se seem to imply mass change with velocity.

It is well known that very fast particles produce very large effects as they approach the velocity of light. It might be thought that this infinite limit effect implies mass change with velocity; because $m = m_0 \gamma$ goes to infinity as $v \rightarrow c$. But other types of reactions can also go to infinity as the velocity approaches c . The force implied by the Weber potential in the form given by Eq. (2) can go to infinity as $v \rightarrow c$. The Weber force on a particle moving in a constant electric field \mathbf{E} (for a zero velocity charge), as given by Eq. (78) may also be written as

$$\mathbf{F} = e\mathbf{E}\gamma, \quad (101)$$

which becomes infinite as $v \rightarrow c$.

If it is discovered from appropriate experiments (such as proposed in Section 12 below) that mass actually does change with velocity in the usually assumed way, then the following explanation might be possible: If fundamental forces are all of the form

$$\mathbf{F} = \mathbf{F}_0 \gamma, \quad (102)$$

where \mathbf{F}_0 is the force when the velocity of the particle on which the force acts is small or zero, then it might be postulated that the kinetic reaction is not $d\mathbf{p}/dt$ but $\gamma d\mathbf{p}/dt$. Following this speculation then gives

$$\mathbf{F} = \mathbf{F}_0 \gamma = \gamma d(m_0 \gamma \mathbf{v})/dt \quad (103)$$

and

$$\mathbf{F}_0 = d(m_0 \gamma \mathbf{v})/dt, \quad (104)$$

as is usually assumed.

11. THE WEBER VELOCITY SQUARED FORCES EXIST

The only serious objection to Weber electrodynamics that has ever been raised is the fact that the Weber forces between a stationary charge and a charge moving with a velocity squared, as given by Eq. (15), had never been observed. As discussed in Section 1.3 above this force between a conduction current and a stationary charge is extremely small (making the Fechner hypothesis unnecessary). Now, however, it has been shown here in Sections 8 and 9 above from the prediction of the Kaufmann experiment and the prediction of the fine structure of the energy levels of the hydrogen atom that the velocity squared Weber forces do, in fact, exist.

In addition, these forces must exist to conserve energy for an isolated system of moving charges. These forces permit a stable nonradiating hydrogen atom, as discussed in Section 9 above. A universe filled with moving charges in isolated systems conserving energy is tacit proof of the existence of these velocity squared Weber forces (which are, of course, completely lacking in Maxwell electrodynamics).

12. PROPOSED EXPERIMENTS TO DETECT MASS CHANGE WITH VELOCITY

The problem in trying to deduce theories appropriate for fast particles from past experiments has been the fact that in these experiments particle velocities have not actually been measured. The velocities assumed have been a function of the electrodynamics assumed. For example, it has been assumed that crossed electric and magnetic fields select a known velocity prescribed by Maxwell electrodynamics, $v = cE/B$. But, as seen above, Eq. (78), Weber electrodynamics yields a different velocity. Not only is the inertial force dp/dt to be determined as a function of large velocities; but also the electrodynamics must be determined as a function of large velocities.

The only possible way of avoiding theoretical errors is to measure particle velocities directly with a chopping device. The only sure way of measuring a meaningful velocity for a fast particle is to use a mechanical device such as Marinov's⁽⁶⁶⁾ toothed-wheels setup. Marinov mounted two toothed wheels on the ends of a rotating shaft. Particles passing through a gap between the teeth of the first wheel can pass through a gap between the teeth of the second wheel only if the velocity of the particles is such that

$$v = L \Omega / \theta, \quad (105)$$

where L is the length of the shaft rotating with the angular velocity Ω and θ is the angular position of the gap between the teeth of the second wheel relative to the gap in the first wheel when the shaft is stationary. With no particular care Marinov has measured the oneway velocity of photons to a first place accuracy. With a little more care it should be possible to measure the actual velocity of particles near the velocity of light c to 2 or 3 places by this method.

Assuming such a toothed-wheels device is available, then the actual velocity of a fast particle can be measured as a function of the state in which it is prepared, as proposed below.

12.1 The velocity of a charged particle accelerated by an electric field

According to all theories when the velocity is small enough the differential equation for the motion of a particle of charge e and mass m_0 in a uniform electric field E in the x direction is

$$eE = m_0 dv/dt. \quad (106)$$

Multiplying by v and integrating, assuming $v = v_0$ when $x = 0$ and $t = 0$,

$$m_0 (v^2 - v_0^2)/2 - eV = 0, \quad (107)$$

where $V = Ex$ is the potential difference through which the particle moves from $x = 0$ to x . The quantities v_0 , v , and V are to be measured. According to Weber electrodynamics and Newtonian mechanics the differential equation for the motion may be taken from Eq. (78) as

$$eE\gamma = m_0 dv/dt. \quad (108)$$

The energy integral becomes

$$m_0 (v^2 - v_0^2)/2 - eV = eV(v^2 + v_0^2)/4c^2. \quad (109)$$

Assuming Maxwell electrodynamics and mass change with velocity the differential equation for the particle motion becomes

$$eE = m_0 d(\gamma v)/dt. \quad (110)$$

The energy integral becomes

$$m_0(v^2 - v_0^2)/2 - eV = -3eV(v^2 + v_0^2)/4c^2. \quad (111)$$

It should not be difficult to distinguish between these two possibilities, Eq. (109) or (111). Weber electrodynamics predicts a + 1 for the coefficient of the right side of Eq. (109); while the Maxwell theory plus mass change with velocity predicts a - 3 for the coefficient of the right side of Eq. (111). According to the best evidence presently available the Weber result (109) is to be expected.

12.2 The velocity of a charged particle in a magnetic field

According to Weber electrodynamics and Newtonian mechanics a particle of charge e and mass m_0 moving transverse to a magnetic field B moves in a circle of radius r such that

$$m_0 v^2/r = evB/c, \quad (112)$$

which yields

$$m_0 v - erB/c = 0. \quad (113)$$

According to Maxwell electrodynamics and mass change with velocity Eq. (112) must be replaced by

$$m_0 \gamma v^2/r = evB/c; \quad (114)$$

and to first power in v^2/c^2

$$m_0 v - erB/c = -m_0 v^2/2c^2. \quad (115)$$

Here the velocity v , the magnetic field B , and the radius r are to be determined experimentally to distinguish between Eq. (113) with no mass change with velocity and Eq. (115) with mass change with velocity. From the evidence presently available the Weber result (113) is to be expected.

References

1. W. E. Weber, *Abh. Leibnizens Ges., Leip.* 316 (1846); *Ann. der Phys.* 73, 229 (1848); *Wilhelm Weber's Werke*, Vols. 1-6 (Julius Springer, Berlin, 1893).
2. Th. E. Phipps, private communication to be published.
3. H. Helmholtz, *Phil. Mag.* 44, 530 (1872); *J. für Math.* 75, 35 (1873).
4. J. P. Wesley, in *Proc. Int. Conf. Space-Time Absoluteness* (East-West, 8044 Graz, Austria, 1982) eds. S. Marinov and J. P. Wesley, pp. 175-182; *Causal Quantum Theory* (Benjamin Wesley, 7712 Blumberg, West Germany, 1983) pp. 173-180; in *Progress in Space-Time Physics 1987* (Benjamin Wesley, 7712 Blumberg, West Germany, 1987) ed. J. P. Wesley, pp. 170-209.
5. J. P. Wesley, *Spec. Sci. Tech.* 10, 47 (1987). In this previous paper the electromagnetic field for the Weber force on a stationary charge due to an accelerating charge was derived; but the inverse, which occurs in the Weber theory and which is necessary to preserve the symmetry of the Weber theory, was overlooked, namely the electromagnetic field for the Weber force on an accelerating charge due to a stationary charge. The Eqs. (9)-(12) appearing here above present the complete Weber theory in terms of fields with the added field G .
6. A. M. Ampere, *Mem. Acad. R. Sci.* 6, 175 (1823) *Memoires sur l'Electrodynamique* (Gauthier Villars, Paris, 1882) Vol. I, p. 25.
7. O. Roemer, *Phil. Trans.* 12, 893 (1677); E. Halley, *Phil. Trans.* 18, 237 (1694).
8. J. Bradley, *London Phil. Trans.* 35, No. 406 (1728).
9. G. Sagnac, *Comptes Rendus* 157, 708, 1410 (1913).
10. A. A. Michelson and H. G. Gale, *Astrophys. J.* 61, 137 (1925).
11. E. K. Conklin, *Nature*, 222, 971 (1969).
12. P. S. Henry, *Nature*, 231, 516 (1971).
13. S. Marinov, *Czech. J. Phys.* B24, 965 (1974); *Gen. Rel. Grav.* 12, 57
14. S. Marinov, *Thorny Way of Truth II* (East-West, 8044 Graz, Austria, 1984) pp. 68-81; J. P. Wesley, in *Progress in Space-Time Physics 1987* (Benjamin Wesley, 7712 Blumberg, West Germany, 1987) ed. J. P. Wesley, pp. 1-10.
15. A. A. Michelson and E. W. Morley, *Am. J. Sci.* 34, 333, 427 (1887); *Astrophys. J.* 37, 190 (1913).

16. W. Voigt, *Göttinger Nachrichten*, p. 41 (1887).
17. J. P. Wesley, *Found. Phys.* **16**, 817 (1986).
18. W. F. Edwards, C. S. Kenyon, and D. K. Lemon, *Phys. Rev. D*, **14**, 922 (1976).
19. J. C. Maxwell, *A Treatise on Electricity and Magnetism* (Clarendon Press, Oxford, 1891) and reprint (Dover Publ., New York, 1954).
20. H. A. Lorentz, *The Theory of Electrons*, 2nd ed. (Dover Publ., New York, 1952).
21. J. D. Jackson, *Classical Electrodynamics* (John Wiley & Sons, New York, 1962).
22. H. H. Grassmann, *Ann. der Phys.* **64**, 1 (1845).
23. P. Graneau, *J. Appl. Phys.* **55**, 2598 (1984).
24. P. Graneau, *Phys. Lett.* **97A**, 253 (1983).
25. P. Graneau and P. N. Graneau, *Appl. Phys. Lett.* **46**, 468 (1985).
26. P. Graneau, *Nature*, **295**, 311 (1982).
27. C. Hering, *Trans. Am. Inst. Elect. Eng.* **42**, 311 (1923).
28. J. P. Wesley, *Bull. Am. Phys. Soc.* **28**, 1310 (1983).
29. F. F. Cleveland, *Phil. Mag., Suppl.* **7**, **21**, 416 (1936).
30. I. A. Robertson, *Phil. Mag.* **36**, 32 (1945).
31. P. T. Pappas, *Il Nuovo Cimento*, **76B**, 189 (1983).
32. P. T. Pappas and P. G. Moyssides, *Phys. Lett.* **111A**, 193 (1985).
33. P. Graneau, *J. Appl. Phys.* **53**, 6648 (1982).
34. P. Graneau, *Phys. Lett.* **107A**, 235 (1985).
35. P. Graneau, *IEEE Trans, Magn.* **MAG-20**, 444 (1984).
36. P. G. Moyssides and P. T. Pappas, *J. Appl. Phys.* **59**, 19 (1986).
37. V. Peoglos, *J. Phys. D: Appl. Phys.* **21**, 1055 (1988).
38. J. P. Wesley, *J. Phys. D: Appl. Phys.* **22**, 849 (1989).
39. Th. E. Phipps, private communication to be published.
40. P. T. Pappas and T. Vaughan, "Measurement of self-torque on a Z-shaped antenna", a paper submitted for publication (1988).
41. F. J. Müller, in *Progress in Space-Time Physics 1987* (Benjamin Wesley, 7712 Blumberg, West Germany, 1987) ed. J. P. Wesley, pp. 156-169.
42. E. Kennard, *Phil. Mag.* **33**, 179 (1917).
43. G. I. Cohn, *Elect. Eng.* **68**, 441.
44. E. G. Cullwick, *Electromagnetism and Relativity* (Longmans, London, 1959) pp. 129 and 140.

45. R. P. Feynman, R. B. Leighton, and M. Sands, *The Feynman Lectures on Physics* (Addison-Wesley, Reading, MA, 1964) Vol. II Sections 17-1 and 2.
46. N. Savage, *Elect. Eng.* **68**, 645 (1949).
47. W. Panofsky and M. Phillips, *Classical Electricity and Magnetism* (Addison-Wesley, Reading, MA, 1962) pp. 338-9.
48. P. Scanlon, R. Henriksen, and J. Allen, *Am. J. Phys.* **37**, 698 (1969).
49. M. Faraday, *Experimental Research in Electricity* (Encyclopedia Britannica, London, 1952) Series II, art. 218.
50. G. Trocheris, *Phil. Mag.* **40**, 1143 (1949).
51. M. Faraday, *Faraday's Diary* (Bell, London, 1932) ed. T. Martin, Vol. 1, p. 384.
52. A. K. T. Assis, *Phys. Lett. A*, **136**, 277 (1989).
53. W. Kaufmann, *Gött. Nachr.* **143** (1901), **291** (1902), **90** (1903); *Ann. der Phys.* **19**, 487 (1906).
54. A. H. Bucherer, *Ann. der Phys.* **28**, 585; **30**, 974 (1909).
55. E. Hupka, *Ann. der Phys.* **31**, 169 (1910).
56. A. Bestelmeyer, *Ann. der Phys.* **30**, 166 (1909); **32**, 231 (1910).
57. G. Neumann, *Ann. der Phys.* **45**, 529 (1914).
58. C. E. Guye, S. Ratnowsky, and Lavanchy, *Mém. Soc. Phys. Genève*, **39**, 273 (1921).
59. R. A. Tricker, *Proc. Roy. Soc.* **A109**, 384 (1925).
60. C. T. Zahn and A. H. Spees, *Phys. Rev.* **53**, 357, 511 (1938).
61. M. M. Rogers, A. W. McReynolds, and F. T. Rogers, *Phys. Rev.* **57**, 379 (1940).
62. P. S. Faragó and L. Jánossy, *Il Nuovo Cimento* **5**, 1411 (1957).
63. L. Pauling and E. B. Wilson, *Introduction to Quantum Mechanics* (McGraw-Hill, New York, 1935) p. 145.
64. R. B. Leighton, *Principles of Modern Physics* (McGraw-Hill, New York, 1959) p. 201.
65. J. P. Wesley, *Causal Quantum Theory* (Benjamin Wesley, 7712 Blumberg, West Germany, 1983) pp. 150-163; *Found. Phys.* **16**, 817 (1986).
66. S. Marinov, *Spec. Sci. Tech.* **3**, 57 (1980).