

Appendix.

Abstract Duality Theory for Symmetric Tensor $*$ -Categories

(by Michael Müger)

The aim of this appendix is to give a proof of Theorem 389, first proved by S. Doplicher and J. E. Roberts in 1989, according to which every symmetric tensor $*$ -category with conjugates, direct sums, subobjects and $\text{End } \mathbf{1} = \mathbb{C}$ is equivalent to the category of finite dimensional unitary representations of a uniquely determined compact supergroup. Not much of this material is new, but Theorem 403 probably is, and see Remark 434. However, this seems to be the first exposition of the reconstruction theorem for symmetric tensor categories that gives complete and streamlined proofs, including a short and transparent proof of Tannaka's classical theorem. In the first section we provide the necessary concepts and results of category theory to the extent that they don't involve the notion of fiber functor, whereas the second section is concerned with the Tannaka theory proper. Our main reference for category theory is [Mac Lane, 1998], preferably the second edition. The reader having some experience with categories is advised to skip directly to Section B, using Section A as a reference when needed.

A CATEGORICAL PRELIMINARIES

A.1 Basics

DEFINITION 300. A *category* \mathcal{C} consists of:

- A class $\text{Obj } \mathcal{C}$ of *Objects*. We denote the objects by capital letters X, Y, \dots
- For any two objects X, Y a set $\text{Hom}_{\mathcal{C}}(X, Y)$ of *arrows* (or morphisms); we write $f : X \rightarrow Y$ to indicate that $f \in \text{Hom}_{\mathcal{C}}(X, Y)$, and we omit the subscript \mathcal{C} whenever there is no risk of confusion.
- For any object X a distinguished arrow $\text{id}_X \in \text{End}(X) = \text{Hom}(X, X)$.
- For each $X, Y, Z \in \text{Obj } \mathcal{C}$, a function $\circ : \text{Hom}(Y, Z) \times \text{Hom}(X, Y) \rightarrow \text{Hom}(X, Z)$ such that:

$$h \circ (g \circ f) = (h \circ g) \circ f,$$

and

$$\text{id}_Y \circ f = f, \quad g \circ \text{id}_X = g,$$

whenever $f \in \text{Hom}(X, Y)$, $g \in \text{Hom}(Y, Z)$, and $h \in \text{Hom}(Z, W)$.

DEFINITION 301. A morphism $f \in \text{Hom}(X, Y)$ is an *isomorphism* iff it is invertible, i.e. there is a $g \in \text{Hom}(Y, X)$ such that $g \circ f = \text{id}_X$ and $f \circ g = \text{id}_Y$. If an isomorphism $X \rightarrow Y$ exists, we write $X \cong Y$.

DEFINITION 302. If \mathcal{C} is a category, then a *subcategory* $\mathcal{D} \subset \mathcal{C}$ is defined by a subclass $\text{Obj } \mathcal{D} \subset \text{Obj } \mathcal{C}$ and, for every $X, Y \in \text{Obj } \mathcal{D}$, a subset $\text{Hom}_{\mathcal{D}}(X, Y) \subset \text{Hom}_{\mathcal{C}}(X, Y)$ such that $\text{id}_X \in \text{Hom}_{\mathcal{D}}(X, X)$ for all $X \in \text{Obj } \mathcal{D}$ and the morphisms in \mathcal{D} is closed under the composition \circ of \mathcal{C} . A subcategory $\mathcal{D} \subset \mathcal{C}$ is *full* if $\text{Hom}_{\mathcal{D}}(X, Y) = \text{Hom}_{\mathcal{C}}(X, Y)$ for all $X, Y \in \text{Obj } \mathcal{D}$.

DEFINITION 303. A (covariant) *functor* F from category \mathcal{C} to category \mathcal{D} maps objects of \mathcal{C} to objects of \mathcal{D} and arrows of \mathcal{C} to arrows of \mathcal{D} such that $F(g \circ f) = F(g) \circ F(f)$, and $F(\text{id}_X) = \text{id}_{F(X)}$. A *contravariant functor* is just like a covariant functor except that it reverses the order of arrows.

DEFINITION 304. A functor $F : \mathcal{C} \rightarrow \mathcal{D}$ is *faithful*, respectively *full*, if the map

$$F_{X,Y} : \text{Hom}_{\mathcal{C}}(X, Y) \rightarrow \text{Hom}_{\mathcal{D}}(F(X), F(Y))$$

is injective, respectively surjective, for all $X, Y \in \text{Obj } \mathcal{C}$.

DEFINITION 305. A functor $F : \mathcal{C} \rightarrow \mathcal{D}$ is *essentially surjective* if for every $Y \in \text{Obj } \mathcal{D}$ there is an $X \in \text{Obj } \mathcal{C}$ such that $F(X) \cong Y$.

DEFINITION 306. If $F : \mathcal{C} \rightarrow \mathcal{D}$ and $G : \mathcal{C} \rightarrow \mathcal{D}$ are functors, then a *natural transformation* η from F to G associates to every $X \in \text{Obj } \mathcal{C}$ a morphism $\eta_X \in \text{Hom}_{\mathcal{D}}(F(X), G(X))$ such that

$$\begin{array}{ccc} F(X) & \xrightarrow{F(s)} & F(Y) \\ \eta_X \downarrow & & \downarrow \eta_Y \\ G(X) & \xrightarrow{G(s)} & G(Y) \end{array}$$

commutes for every arrow $s \in \text{Hom}_{\mathcal{C}}(X, Y)$. If η_X is an isomorphism for every $X \in \text{Obj } \mathcal{C}$, then η is said to be a *natural isomorphism*.

DEFINITION 307. A functor $F : \mathcal{C} \rightarrow \mathcal{D}$ is an *equivalence of categories* if there exist a functor $G : \mathcal{D} \rightarrow \mathcal{C}$ and natural isomorphisms $\eta : FG \rightarrow \text{id}_{\mathcal{D}}$ and $\varepsilon : \text{id}_{\mathcal{C}} \rightarrow GF$. Two categories are *equivalent*, denoted $F \simeq G$, if there exists an equivalence $F : \mathcal{C} \rightarrow \mathcal{D}$.

DEFINITION 308. A category is *small* if $\text{Obj } \mathcal{C}$ is a set (rather than just a class). A category is *essentially small* if it is equivalent to a small one, i.e. $\text{Obj } \mathcal{C} / \cong$ is a set.

REMARK 309. Without wanting to go into foundational technicalities we point out that the category of a ‘all representations’ of a group is a huge object. However, considered modulo equivalence the representations are of reasonable cardinality, i.e. are a set.

A.2 Tensor categories and braidings

DEFINITION 310. Given two categories \mathcal{C}, \mathcal{D} , the product category $\mathcal{C} \times \mathcal{D}$ is defined by

$$\begin{aligned} \text{Obj}(\mathcal{C} \times \mathcal{D}) &= \text{Obj}\mathcal{C} \times \text{Obj}\mathcal{D}, \\ \text{Hom}_{\mathcal{C} \times \mathcal{D}}(X \times Y, Z \times W) &= \text{Hom}_{\mathcal{C}}(X, Z) \times \text{Hom}_{\mathcal{D}}(Y, W), \\ \text{id}_{X \times Y} &= \text{id}_X \times \text{id}_Y \end{aligned}$$

with the obvious composition $(a \times b) \circ (c \times d) := (a \circ c) \times (b \circ d)$.

DEFINITION 311. A strict tensor category (or strict monoidal category) is a category \mathcal{C} equipped with a distinguished object $\mathbf{1}$, the tensor unit, and a functor $\otimes : \mathcal{C} \times \mathcal{C} \rightarrow \mathcal{C}$ such that:

1. \otimes is associative on objects and morphisms, i.e. $(X \otimes Y) \otimes Z = X \otimes (Y \otimes Z)$ and $(s \otimes t) \otimes u = s \otimes (t \otimes u)$ for all $X, Y, Z, X', Y', Z' \in \text{Obj}\mathcal{C}$ and all $s : X \rightarrow X', t : Y \rightarrow Y', u : Z \rightarrow Z'$.
2. The unit object behaves as it should: $X \otimes \mathbf{1} = X = \mathbf{1} \otimes X$ and $s \otimes \text{id}_{\mathbf{1}} = s = \text{id}_{\mathbf{1}} \otimes s$ for all $s : X \rightarrow Y$.
3. The interchange law

$$(a \otimes b) \circ (c \otimes d) = (a \circ c) \otimes (b \circ d)$$

holds whenever $a \circ c$ and $b \circ d$ are defined.

REMARK 312. Many categories with tensor product are not strict in the above sense. A tensor category is a category equipped with a functor $\otimes : \mathcal{C} \times \mathcal{C} \rightarrow \mathcal{C}$, a unit $\mathbf{1}$ and natural isomorphisms $\alpha_{X,Y,Z} : (X \otimes Y) \otimes Z \rightarrow X \otimes (Y \otimes Z)$, $\lambda_X : \mathbf{1} \otimes X \rightarrow X$, $\rho_X : X \otimes \mathbf{1} \rightarrow X$ satisfying certain identities. The notions of braiding, monoidal functor and monoidal natural transformation generalize to such categories. The generality achieved by considering non-strict categories is only apparent: By the coherence theorems, every (braided/symmetric) tensor category is monoidally naturally equivalent to a strict one. See [Mac Lane, 1998; Joyal and Street, 1993a] for all this.

Strictly speaking (pun intended) the categories of vector spaces and Hilbert spaces are not strict. However, the coherence theorems allow us to pretend that they are, simplifying the formulae considerably. The reader who feels uncomfortable with this is invited to insert the isomorphisms α, λ, ρ wherever they should appear.

DEFINITION 313. A (full) tensor subcategory of a tensor category \mathcal{C} is a (full) subcategory $\mathcal{D} \subset \mathcal{C}$ such that $\text{Obj}\mathcal{D}$ contains the unit object $\mathbf{1}$ and is closed under the tensor product \otimes .

DEFINITION 314. Let \mathcal{C}, \mathcal{D} be strict tensor categories. A tensor functor (or a monoidal functor) is a functor $F : \mathcal{C} \rightarrow \mathcal{D}$ together with isomorphisms $d_{X,Y}^F : F(X) \otimes F(Y) \rightarrow F(X \otimes Y)$ for all $X, Y \in \mathcal{C}$ and a morphism $e^F : \mathbf{1}_{\mathcal{D}} \rightarrow F(\mathbf{1}_{\mathcal{C}})$ such that

1. The morphisms $d_{X,Y}^F$ are natural w.r.t. both arguments.
2. For all $X, Y, Z \in \mathcal{C}$ the following diagram commutes:

$$(56) \quad \begin{array}{ccc} F(X) \otimes F(Y) \otimes F(Z) & \xrightarrow{d_{X,Y}^F \otimes \text{id}_{F(Z)}} & F(X \otimes Y) \otimes F(Z) \\ \downarrow \text{id}_{F(X)} \otimes d_{Y,Z}^F & & \downarrow d_{X \otimes Y, Z}^F \\ F(X) \otimes F(Y \otimes Z) & \xrightarrow{d_{X, Y \otimes Z}^F} & F(X \otimes Y \otimes Z) \end{array}$$

3. The following compositions are the identity morphisms of $F(X)$

$$(57) \quad \begin{array}{l} F(X) \equiv F(X) \otimes \mathbf{1}_{\mathcal{D}} \xrightarrow{\text{id}_{F(X)} \otimes e^F} F(X) \otimes F(\mathbf{1}_{\mathcal{C}}) \xrightarrow{d_{X, \mathbf{1}}} F(X \otimes \mathbf{1}_{\mathcal{C}}) \equiv F(X) \\ F(X) \equiv \mathbf{1}_{\mathcal{D}} \otimes F(X) \xrightarrow{e^F \otimes \text{id}_{F(X)}} F(\mathbf{1}_{\mathcal{C}}) \otimes F(X) \xrightarrow{d_{\mathbf{1}, X}} F(\mathbf{1}_{\mathcal{C}} \otimes X) \equiv F(X) \end{array}$$

for all $X \in \mathcal{C}$.

If \mathcal{C}, \mathcal{D} are tensor $*$ -categories and F is $*$ -preserving, the isomorphisms $e, d_{X,Y}$ are required to be unitary.

DEFINITION 315. Let \mathcal{C}, \mathcal{D} be strict tensor categories and $F, G : \mathcal{C} \rightarrow \mathcal{D}$ tensor functors. A natural transformation $\alpha : \mathcal{C} \rightarrow \mathcal{D}$ is monoidal if

$$\begin{array}{ccc} F(X) \otimes F(Y) & \xrightarrow{d_{X,Y}^F} & F(X \otimes Y) \\ \alpha_X \otimes \alpha_Y \downarrow & & \downarrow \alpha_{X \otimes Y} \\ G(X) \otimes G(Y) & \xrightarrow{d_{X,Y}^G} & G(X \otimes Y) \end{array}$$

commutes for all $X, Y \in \mathcal{C}$ and the composite $\mathbf{1}_{\mathcal{D}} \xrightarrow{e^F} F(\mathbf{1}) \xrightarrow{\alpha_{\mathbf{1}}} G(\mathbf{1})$ coincides with e^G .

REMARK 316. A tensor functor between strict tensor categories is called strict if all the isomorphisms $d_{X,Y}$ and e are identities. However, it is not true that every tensor functor is equivalent to a strict one!

DEFINITION 317. A tensor functor $F : \mathcal{C} \rightarrow \mathcal{D}$ is an *equivalence* (of tensor categories) if there exist a tensor functor $G : \mathcal{D} \rightarrow \mathcal{C}$ and monoidal natural isomorphisms $GF \rightarrow \text{id}_{\mathcal{C}}$ and $FG \rightarrow \text{id}_{\mathcal{D}}$.

PROPOSITION 318. *A functor $F : \mathcal{C} \rightarrow \mathcal{D}$ is an equivalence iff F is faithful, full and essentially surjective. A tensor functor $F : \mathcal{C} \rightarrow \mathcal{D}$ of (strict) tensor categories is an equivalence of tensor categories iff F is faithful, full and essentially surjective.*

Proof. For the first statement see [Mac Lane, 1998, Theorem 1, p. 91] and for the second [Saavedra Rivano, 1972]. ■

DEFINITION 319. A braiding for a strict tensor category \mathcal{C} is a family of isomorphisms $c_{X,Y} : X \otimes Y \rightarrow Y \otimes X$ for all $X, Y \in \text{Obj } \mathcal{C}$ satisfying

1. Naturality: For every $s : X \rightarrow X', t : Y \rightarrow Y'$, the diagram

$$\begin{array}{ccc}
 X \otimes Y & \xrightarrow{c_{X,Y}} & Y \otimes X \\
 s \otimes t \downarrow & & \downarrow t \otimes s \\
 X' \otimes Y' & \xrightarrow{c_{X',Y'}} & Y' \otimes X'
 \end{array}$$

commutes.

2. The ‘braid equations’ hold, i.e. the diagrams

$$\begin{array}{ccc}
 X \otimes Y \otimes Z & \xrightarrow{c_{X,Y} \otimes \text{id}_Z} & Y \otimes X \otimes Z & X \otimes Y \otimes Z & \xrightarrow{\text{id}_X \otimes c_{Y,Z}} & X \otimes Z \otimes Y \\
 \searrow c_{X,Y \otimes Z} & & \downarrow \text{id}_Y \otimes c_{X,Z} & \searrow c_{X \otimes Y, Z} & & \downarrow c_{X,Z} \otimes \text{id}_Y \\
 & & Y \otimes Z \otimes X & & & Z \otimes X \otimes Y
 \end{array}$$

commute for all $X, Y, Z \in \text{Obj } \mathcal{C}$.

If, in addition, $c_{Y,X} \circ c_{X,Y} = \text{id}_{X \otimes Y}$ holds for all X, Y , the braiding is called a symmetry.

A strict braided (symmetric) tensor category is a strict tensor category equipped with a braiding (symmetry).

DEFINITION 320. If \mathcal{C}, \mathcal{D} are strict braided (symmetric) tensor categories, a tensor functor $F : \mathcal{C} \rightarrow \mathcal{D}$ is braided (symmetric) if

$$F(c_{X,Y}) = c_{F(X),F(Y)} \quad \forall X, Y \in \text{Obj } \mathcal{C}.$$

(Note that on the l.h.s., respectively r.h.s., c is the braiding of \mathcal{C} , respectively \mathcal{D} .)

There is no additional condition for a monoidal natural transformation to be braided/symmetric.

A.3 Graphical notation for tensor categories

We will on some occasions use the so-called ‘tangle diagrams’ for computations in strict (braided) tensor categories, hoping that the reader has seen them before. By way of explanation (for much more detail see e.g. [Kassel, 1995]) we just say that identity morphisms (equivalently, objects) are denoted by vertical lines, a morphism $s : X \rightarrow Y$ by a box with lines corresponding to X and Y entering from below and above, respectively. Compositions and tensor products of morphisms are denoted by vertical and horizontal juxtaposition, respectively. Braiding morphisms are represented by a crossing and the duality morphisms r, \bar{r} by arcs:

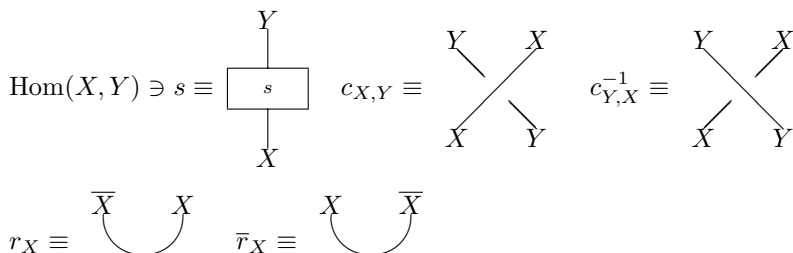

(If c is a symmetry, both lines in the braiding are drawn unbroken.) The reason for using this diagrammatic representation is that even relatively simple formulae in tensor categories become utterly unintelligible as soon as morphisms with ‘different numbers of in- and outputs’ are involved, like $s : A \rightarrow B \otimes C \otimes D$. This gets even worse when braidings and duality morphisms are involved. Just one example of a complete formula: The interchange law $s \circ \text{id}_W \circ \text{id}_X \otimes t = \text{id}_Y \otimes t \circ s \circ \text{id}_Z$ for $s : X \rightarrow Y, t : Z \rightarrow W$ is drawn as

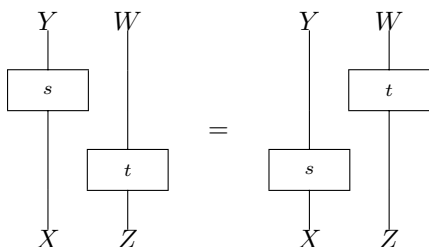

The diagram (correctly!) suggests that we may pull morphisms alongside each other.

A.4 Additive, \mathbb{C} -linear and $*$ -categories

DEFINITION 321. A category is an Ab-category if all hom-sets are abelian groups and the composition \circ is bi-additive.

DEFINITION 322. Let X, Y, Z be objects in a Ab-category. Then Z is called a *direct sum* of X and Y , denoted $Z \cong X \oplus Y$, if there are morphisms $u : X \rightarrow$

$Z, u' : Z \rightarrow X, v : Y \rightarrow Z, v' : Z \rightarrow Y$ such that $u' \circ u = \text{id}_X, v' \circ v = \text{id}_Y$ and $u \circ u' + v \circ v' = \text{id}_Z$. (Note that every $Z' \cong Z$ also is a direct sum of X and Y . Thus direct sums are defined only up to isomorphism, which is why we don't write $Z = X \oplus Y$.) We say that \mathcal{C} has *direct sums* if there exists a direct sum $Z \cong X \oplus Y$ for any two object X, Y .

DEFINITION 323. An object $\mathbf{0}$ in a category \mathcal{C} is called a zero object if, for every $X \in \mathcal{C}$, the sets $\text{Hom}(X, \mathbf{0})$ and $\text{Hom}(\mathbf{0}, X)$ both contain precisely one element. A morphism to or from a zero object is called a zero morphism.

It is immediate from the definition that any two zero objects are isomorphic. If a category doesn't have a zero object it is straightforward to add one. If z is a zero morphism and f is any morphism, then $z \circ f, f \circ z, z \otimes f, f \otimes z$ are zero morphisms (provided they make sense).

DEFINITION 324. An *additive* category is an Ab-category that has a zero object and direct sums.

EXAMPLE 325. The category of abelian groups (with the trivial group as zero).

DEFINITION 326. A category \mathcal{C} is called \mathbb{C} -linear if $\text{Hom}(X, Y)$ is a \mathbb{C} -vector space for all $X, Y \in \text{Obj } \mathcal{C}$ and the composition map $\circ : (f, g) \mapsto g \circ f$ is bilinear. If \mathcal{C} is a tensor category we require that also $\otimes : (f, g) \mapsto g \otimes f$ is bilinear. Functors between \mathbb{C} -linear category are always assumed to be \mathbb{C} -linear, i.e. $\text{Hom}_{\mathcal{C}}(X, Y) \rightarrow \text{Hom}_{\mathcal{D}}(F(X), F(Y))$ must be \mathbb{C} -linear.

DEFINITION 327. A *positive *-operation* on a \mathbb{C} -linear category is a family of maps that to every morphism $s \in \text{Hom}(X, Y)$ associates a morphism $s^* \in \text{Hom}(Y, X)$. This map must be antilinear, involutive ($(s^*)^* = s$) and positive in the sense that $s^* \circ s = 0$ implies $s = 0$. A **-category* is a \mathbb{C} -linear category equipped with a positive *-operation. A *tensor *-category* is a tensor category with a positive *-operation such that $(s \otimes t)^* = s^* \otimes t^*$ for all s, t . We consider only unitary braidings (symmetries) of tensor *-categories.

DEFINITION 328. A morphism $v : X \rightarrow Y$ in a *-category is called an *isometry* if $v^* \circ v = \text{id}_X$. An isometry v is called a *unitary* if it satisfies $v \circ v^* = \text{id}_Y$. A morphism $p \in \text{End } X$ is called a projector if $p = p \circ p = p^*$. We say that \mathcal{C} has *subobjects* if for every projector $p \in \text{End } X$ there exists an isometry $v : Y \rightarrow X$ such that $v \circ v^* = p$. In a *-category we strengthen Definition 322 by requiring that $u' = u^*, v' = v^*$, i.e. u, v must be isometries.

DEFINITION 329. A functor F between *-categories is **-preserving* if $F(s^*) = F(s)^*$ for every morphism s . The isomorphisms $d_{X,Y}, e$ coming with a functor between tensor *-categories coming with a functor of tensor *-categories are required to be unitaries.

DEFINITION 330. Let \mathcal{C} be a tensor *-category and $X \in \text{Obj } \mathcal{C}$. An object $\overline{X} \in \text{Obj } \mathcal{C}$ is called a *conjugate* object of X if there exist morphisms $r : \mathbf{1} \rightarrow \overline{X} \otimes X$

and $r : \mathbf{1} \rightarrow X \otimes \overline{X}$ satisfying the ‘conjugate equations’

$$\begin{aligned} \text{id}_X \otimes r^* \circ \bar{r} \otimes \text{id}_X &= \text{id}_X, \\ \text{id}_{\overline{X}} \otimes \bar{r}^* \circ r \otimes \text{id}_{\overline{X}} &= \text{id}_{\overline{X}}. \end{aligned}$$

We say that $(\overline{X}, r, \bar{r})$ is a *conjugate* of X . If every non-zero object of \mathcal{C} has a conjugate then we say that \mathcal{C} has conjugates.

Note also that a zero object cannot have a conjugate. If $(\overline{X}, r, \bar{r}), (\overline{X}', r', \bar{r}')$ both are conjugates of X then one easily verifies that $\text{id}_{\overline{X}'} \otimes \bar{r}^* \circ r' \otimes \text{id}_{\overline{X}} : \overline{X} \rightarrow \overline{X}'$ is unitary. Thus the conjugate is unique up to unitary equivalence.

DEFINITION 331. An object X in a \mathbb{C} -linear category is *irreducible* if $\text{End } X = \mathbb{C}\text{id}_X$.

DEFINITION 332. A TC^* is a tensor $*$ -category with finite dimensional hom-sets, with conjugates, direct sums, subobjects and irreducible unit $\mathbf{1}$. A BTC^* is a TC^* with a unitary braiding. An STC^* is a TC^* with a unitary symmetry.

EXAMPLE 333. The tensor $*$ -category \mathcal{H} of finite dimensional Hilbert spaces is a STC^* . The symmetry $c_{H,H'} : H \otimes H' \rightarrow H' \otimes H$ is given by the flip isomorphism $\Sigma : x \otimes y \mapsto y \otimes x$. The conjugate of an object H is the Hilbert space dual \overline{H} . Picking a basis $\{e_i\}$ of H with dual basis $\{f_i\}$, the conjugation morphisms are given by

$$r = \sum_i f_i \otimes e_i, \quad \bar{r} = \sum_i e_i \otimes f_i.$$

In the same way one sees that the category $\text{Rep}_f G$ of finite dimensional unitary representations of a compact group G is an STC^* .

LEMMA 334. A TC^* is semisimple, i.e. every object is a finite direct sum of irreducible objects.

Proof. For every $X \in \mathcal{C}$, $\text{End } X$ is a finite dimensional \mathbb{C} -algebra with a positive involution. Such an algebra is semisimple, to wit a multi matrix algebra. Thus id_X is a sum of projections p_i that are minimal in the sense that $p_i \text{End } X p_i \cong \mathbb{C}$. Since \mathcal{C} has subobjects, there are objects X_i corresponding to the p_i , which are irreducible by minimality of the p_i . Clearly, $X \cong \oplus_i X_i$. ■

DEFINITION 335. A solution (X, r, \bar{r}) of the conjugate equations is called standard if

$$r^* \circ \text{id}_{\overline{X}} \otimes s \circ r = \bar{r}^* \circ s \otimes \text{id}_{\overline{X}} \circ \bar{r}$$

for all $s \in \text{End } X$. In this case, $(\overline{X}, r, \bar{r})$ is called a standard conjugate.

LEMMA 336. Let \mathcal{C} be a TC^* and $(\overline{X}, r, \bar{r})$ a conjugate for $X \in \mathcal{C}$. Let $v_i : X_i \rightarrow X, w_i : \overline{X}_i \rightarrow \overline{X}$ be isometries effecting the direct sum decomposition of X, \overline{X} into irreducibles. Then $(\overline{X}, r, \bar{r})$ is a standard conjugate iff $(\overline{X}_i, w_i^* \otimes v_i^* \circ r, v_i^* \otimes w_i^* \circ \bar{r})$ is a standard conjugate for X_i for all i . Every object admits a standard conjugate.

Proof. For the equivalence claim, see [Longo and Roberts, 1997], in particular Lemma 3.9. (Note that in [Longo and Roberts, 1997], standardness is defined by the property in the statement above.) We use this to prove that every objects admits a standard conjugate. If X is irreducible, we have $\text{End } X = \text{Cid}_X$. Therefore the standardness condition reduces to $r^* \circ r = \bar{r}^* \circ \bar{r}$, thus a conjugate (\bar{X}, r, \bar{r}) can be made standard by rescaling r, \bar{r} . In the general case, we use semisimplicity to find a direct sum decomposition of X into irreducibles X_i . Let $(\bar{X}_i, r_i, \bar{r}_i)$ be standard conjugates of the X_i and put $\bar{X} = \bigoplus \bar{X}_i$. Let $v_i : X_i \rightarrow X$, $w_i : \bar{X}_i \rightarrow \bar{X}$ be the isometries effecting the direct sums. Defining $r = \sum_i w_i \otimes v_i \circ r_i$ and $\bar{r} = \sum_i v_i \otimes w_i \circ \bar{r}_i$, the criterion in the first part of the lemma applies and gives standardness of (\bar{X}, r, \bar{r}) . ■

LEMMA 337. *Let (\bar{X}, r, \bar{r}) be a (standard) conjugate of X , let $p \in \text{End } X$ a projection and define $\bar{p} = r^* \otimes \text{id}_{\bar{X}} \circ \text{id}_{\bar{X}} \otimes p \otimes \text{id}_{\bar{X}} \circ \text{id}_{\bar{X}} \otimes \bar{r} \in \text{End } \bar{X}$. If $v : Y \rightarrow X$, $w : \bar{Y} \rightarrow \bar{X}$ are isometries such that $v \circ v^* = p, w \circ w^* = \bar{p}$ then $(\bar{Y}, w^* \otimes v^* \circ r, v^* \otimes w^* \circ \bar{r})$ is a (standard) conjugate for Y .*

Proof. Omitted. For the easy proof see [Longo and Roberts, 1997] or [Müger, 2000]. ■

LEMMA 338. *If $(\bar{X}, r, \bar{r}), (\bar{Y}, r', \bar{r}')$ are (standard) conjugates of X, Y , respectively, then $(\bar{Y} \otimes \bar{X}, r'', \bar{r}'')$, where $r'' = \text{id}_{\bar{Y}} \otimes r \otimes \text{id}_Y \circ r', \bar{r}'' = \text{id}_X \otimes \bar{r}' \otimes \text{id}_{\bar{X}} \circ \bar{r}$ is a (standard) conjugate for $X \otimes Y$.*

Proof. That $(\bar{Y} \otimes \bar{X}, r'', \bar{r}'')$ is a conjugate is an easy computation. Standardness is less obvious since the map $\text{End } X \otimes \text{End } Y \rightarrow \text{End } X \otimes Y$ need not be surjective. However, it follows using the alternative characterization of standardness given in Lemma 336. ■

PROPOSITION 339. *Let \mathcal{C} be a TC^* . Let $X \in \mathcal{C}$ and let (\bar{X}, r, \bar{r}) be a standard conjugate. Then the map*

$$\text{Tr}_X : \text{End } X \rightarrow \mathbb{C}, \quad s \mapsto r^* \circ \text{id}_{\bar{X}} \otimes s \circ r$$

is well defined, i.e. independent of the choice of (\bar{X}, r, \bar{r}) . It is called the trace. It satisfies

$$\begin{aligned} \text{Tr}_X(s \circ t) &= \text{Tr}_Y(t \circ s) \quad \forall s : Y \rightarrow X, t : X \rightarrow Y, \\ \text{Tr}_{X \otimes Y}(s \otimes t) &= \text{Tr}_X(s) \text{Tr}_Y(t) \quad \forall s \in \text{End } X, t \in \text{End } Y. \end{aligned}$$

Proof. Easy exercise. ■

DEFINITION 340. Let \mathcal{C} be a TC^* and $X \in \mathcal{C}$. The *dimension* of X is defined by $d(X) = \text{Tr}_X(\text{id}_X)$, i.e. $d(X) = r^* \circ r$ for any standard conjugate (\bar{X}, r, \bar{r}) .

LEMMA 341. *The dimension is additive ($d(X \oplus Y) = d(X) + d(Y)$) and multiplicative ($d(X \otimes Y) = d(X)d(Y)$). Furthermore, $d(\bar{X}) = d(X) \geq 1$ for every object, and $d(X) = 1$ implies that $X \otimes \bar{X} \cong \mathbf{1}$, i.e. X is invertible.*

Proof. Additivity is immediate by the discussion of standard conjugates. Multiplicativity of the dimension follows from Lemma 338.

If (\bar{X}, r, \bar{r}) is a standard conjugate for X , then (X, \bar{r}, r) is a standard conjugate for \bar{X} , implying $d(\bar{X}) = d(X)$. The positivity of the $*$ -operation implies that $d(X) = r^* \circ r > 0$. Since $X \otimes \bar{X}$ contains $\mathbf{1}$ as a direct summand, we have $d(X)^2 \geq 1$, thus $d(X) \geq 1$. Finally, if $d(X) = 1$, $\mathbf{1}$ is the only direct summand of $X \otimes \bar{X}$, to wit $X \otimes \bar{X} \cong \mathbf{1}$. Similarly, $\bar{X} \otimes X \cong \mathbf{1}$. ■

DEFINITION 342. Let \mathcal{C} be a BTC^* and $X \in \mathcal{C}$. The twist $\Theta(X) \in \text{End } X$ is defined by

$$\Theta(X) = r^* \otimes \text{id}_X \circ \text{id}_{\bar{X}} \otimes c_{X,X} \circ r \otimes \text{id}_X,$$

where (\bar{X}, r, \bar{r}) is a standard solution of the conjugate equations.

LEMMA 343. Let \mathcal{C} be a BTC^* . Then

- (i) $\Theta(X)$ is well defined, i.e. does not depend on the choice of (\bar{X}, r, \bar{r}) .
- (ii) For every morphism $s : X \rightarrow Y$ we have $\Theta(Y) \circ s = s \circ \Theta(X)$. (I.e., Θ is a natural transformation of the identity functor of \mathcal{C} .)
- (iii) $\Theta(X)$ is unitary.
- (iv) $\Theta(X \otimes Y) = \Theta(X) \otimes \Theta(Y) \circ c_{Y,X} \circ c_{X,Y}$ for all X, Y .
- (v) If \mathcal{C} is an STC^* , this simplifies to $\Theta(X)^2 = \text{id}_X$ and $\Theta(X \otimes Y) = \Theta(X) \otimes \Theta(Y)$ for all $X, Y \in \mathcal{C}$ (i.e., Θ is a monoidal natural transformation of the identity functor of \mathcal{C}). If X, Y are irreducible, we have $\omega(X) = \pm 1$ and $\omega_Z = \omega_X \omega_Y$ for all irreducible direct summands $Z \prec X \otimes Y$.

Proof. (i) is proven as Proposition 339. The other verifications are not-too-difficult computations, for which we refer to [Longo and Roberts, 1997] or [Müger, 2000]. We just comment on (v): In an STC^* we have $c_{X,X}^* = c_{X,X}^{-1} = c_{X,X}$, implying $\Theta(X)^* = \Theta(X)$. Together with unitarity this gives $\Theta(X)^2 = \text{id}_X$. Multiplicativity of Θ in an STC^* follows from $c_{Y,X} \circ c_{X,Y} = \text{id}$. If X, Y are irreducible, we have $\Theta(X) = \omega_X \text{id}_X$, $\Theta(Y) = \omega_Y \text{id}_Y$ and thus $\Theta(X \otimes Y) = \omega_X \omega_Y \text{id}_{X \otimes Y}$. Now $\omega(Z) = \omega_X \omega_Y$ for irreducible $Z \prec X \otimes Y$ follows by naturality of Θ . ■

The following is a reworking of Propositions 4.4 and 4.5 in [Longo and Roberts, 1997].

PROPOSITION 344. Let \mathcal{C}, \mathcal{D} be BTC^* s and $E : \mathcal{C} \rightarrow \mathcal{D}$ a $*$ -preserving braided tensor functor. If (\bar{X}, r, \bar{r}) is a standard conjugate of $X \in \mathcal{C}$, then $(E(\bar{X}), (d_{\bar{X}, X}^E)^{-1} \circ E(r) \circ e^E, (d_{X, \bar{X}}^E)^{-1} \circ E(\bar{r}) \circ e^E)$ is a standard conjugate for $E(X)$. In particular,

$$d(E(X)) = d(X), \quad \Theta(E(X)) = E(\Theta(X)) \quad \forall X \in \mathcal{C}.$$

Proof. We assume for a while that the functor E is strict and that X is irreducible. Let (\bar{X}, r, \bar{r}) be a standard conjugate. Since E preserves the conjugate equations, $(E(\bar{X}), E(r), E(\bar{r}))$ is a conjugate for $E(X)$, but if E is not full, standardness requires proof. We begin with

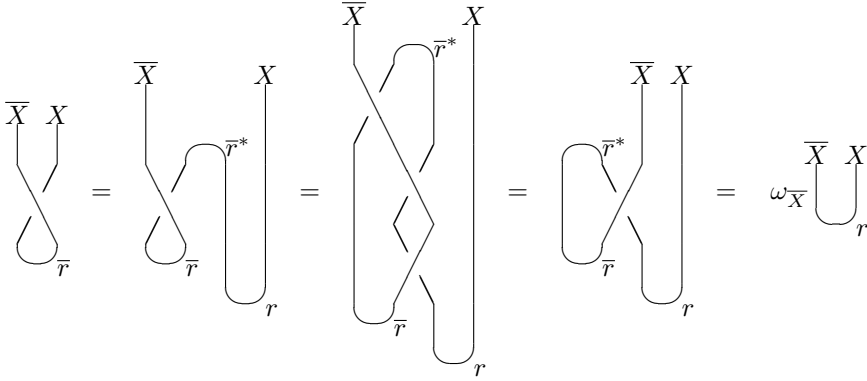

Thus $c_{\bar{X},X}^* \circ \bar{r} = \omega_{\bar{X}} \cdot r$, which is equivalent to $c_{\bar{X},X} \circ r = \bar{\omega}_{\bar{X}} \bar{r}$. Now we let $s \in \text{End } E(X)$ and compute

$$\begin{aligned}
 E(r^*) \circ \text{id}_{E(\bar{X})} \otimes s \circ E(r) &= \\
 &= E(r^*) \circ c_{E(\bar{X}),E(X)}^* \circ c_{E(\bar{X}),E(X)} \circ \text{id}_{E(\bar{X})} \otimes s \circ E(r) \\
 &= (c_{E(\bar{X}),E(X)} \circ E(r))^* \circ c_{E(\bar{X}),E(X)} \circ \text{id}_{E(\bar{X})} \otimes s \circ E(r) \\
 &= (c_{E(\bar{X}),E(X)} \circ E(r))^* \circ s \otimes \text{id}_{E(\bar{X})} \circ c_{E(\bar{X}),E(X)} \circ E(r) \\
 &= E(c_{\bar{X},X} \circ r)^* \circ s \otimes \text{id}_{E(\bar{X})} \circ E(c_{\bar{X},X} \circ r) \\
 &= E(\bar{\omega}_{\bar{X}} \bar{r})^* \circ s \otimes \text{id}_{E(\bar{X})} \circ E(\bar{\omega}_{\bar{X}} \bar{r}) \\
 &= E(\bar{r})^* \circ s \otimes \text{id}_{E(\bar{X})} \circ E(\bar{r}),
 \end{aligned}$$

which means that $(E(\bar{X}), E(r), E(\bar{r}))$ is a standard conjugate for $E(X)$. (We have used unitarity of the braiding, the fact that E is $*$ -preserving and braided, $c_{\bar{X},X} \circ r = \bar{\omega}_{\bar{X}} \bar{r}$ and $|\omega_{\bar{X}}| = 1$.)

Now let X be reducible, (\bar{X}, r, \bar{r}) a standard conjugate and let $v_i : X_i \rightarrow X$, $w_i : \bar{X}_i \rightarrow \bar{X}$ be isometries effecting the decompositions into irreducibles. Defining $r_i = w_i^* \otimes v_i^* \circ r$, $\bar{r}_i = v_i^* \otimes w_i^* \circ \bar{r}$, $(\bar{X}_i, r_i, \bar{r}_i)$ is standard by Lemma 336. Thus $(E(\bar{X}_i), E(r_i), E(\bar{r}_i))$ is standard by the first half of this proof. In view of $E(r) = E(\sum_i w_i \otimes v_i \circ r_i) = \sum_i E(w_i) \otimes E(v_i) \circ E(r_i)$ and similarly for $E(\bar{r})$, it follows that $(E(\bar{X}), E(r), E(\bar{r}))$ is standard (since it is a direct sum of standard conjugates).

If E is not strict, we have to insert the unitaries $d_{X,Y}^E : E(X) \otimes E(Y) \rightarrow E(X \otimes Y)$, $e^E : \mathbf{1} \rightarrow E(\mathbf{1})$ at the obvious places in the above computations, but nothing else changes. That E preserves dimensions follows since the dimension is defined in terms of a standard conjugate. Finally, standardness of $(E(\bar{X}), E(r), E(\bar{r}))$ together with $E(c_{X,Y}) = c_{E(X),E(Y)}$ imply $\Theta(E(X)) = E(\Theta(X))$. ■

We close this subsection by commenting on the relation of $*$ -categories with the more general notion of C^* -tensor categories of [Doplicher and Roberts, 1989; Longo and Roberts, 1997].

DEFINITION 345. A C^* -category is a \mathbb{C} -linear category with a positive $*$ -operation, where $\text{Hom}(X, Y)$ is a Banach space for all X, Y and $\|s \circ t\|_{\text{Hom}(X, Z)} \leq \|s\|_{\text{Hom}(X, Y)} \cdot \|t\|_{\text{Hom}(Y, Z)}$ for all $s : X \rightarrow Y, t : Y \rightarrow Z$ and $\|s^* \circ s\|_{\text{End } X} = \|s\|_{\text{Hom}(X, Y)}^2$ for all $s : X \rightarrow Y$. (Thus each $\text{End } X$ is a C^* -algebra.) A C^* -tensor category is a C^* -category and a tensor category such that $\|s \otimes t\| \leq \|s\| \cdot \|t\|$ for all s, t .

PROPOSITION 346. [Longo and Roberts, 1997] *Let \mathcal{C} be a C^* -tensor category with direct sums and irreducible unit. Whenever $X, Y \in \mathcal{C}$ admit conjugates then $\dim \text{Hom}(X, Y) < \infty$. Thus a C^* -tensor category with direct sums, subobjects, conjugates and irreducible unit is a TC^* . Conversely, given a TC^* , there are unique norms on the spaces $\text{Hom}(X, Y)$ rendering \mathcal{C} a C^* -tensor category.*

Proof. Assume that $X \in \mathcal{C}$ has a conjugate (X, r, \bar{r}) . Then the map $\text{End } X \rightarrow \text{Hom}(\mathbf{1}, \bar{X} \otimes X), s \mapsto \text{id}_{\bar{X}} \otimes s \circ r$ is an isomorphism of vector spaces since $t \mapsto \bar{r}^* \circ \text{id}_X \circ \text{id}_X \otimes t$ is its inverse, as is verified using the conjugate equations. Now, $\text{Hom}(\mathbf{1}, \bar{X} \otimes X)$ is a pre-Hilbert space w.r.t. the inner product $\langle a, b \rangle \text{id}_{\mathbf{1}} = a^* \circ b$, and it is complete because \mathcal{C} is a C^* -tensor category. Choose an orthogonal basis $(e_i)_{i \in I}$ in $\text{Hom}(\mathbf{1}, \bar{X} \otimes X)$. Then each $e_i : \mathbf{1} \rightarrow \bar{X} \otimes X$ is an isometry and $e_i^* \circ e_j = 0$ for $i \neq j$, implying that $\bar{X} \otimes X$ contains $\#I$ copies of $\mathbf{1}$ as direct summands. Since X has a conjugate, so does $\bar{X} \otimes X$, but this is impossible if $\#I$ is infinite. Thus $\text{Hom}(\mathbf{1}, \bar{X} \otimes X)$ and therefore $\text{End } X$ is finite dimensional.

Given arbitrary X, Y having conjugates, pick a direct sum $Z \cong X \oplus Y$ with isometries $u : X \rightarrow Z, v : Y \rightarrow Z$. Then also Z has a conjugate, cf. Lemma 336, and therefore $\dim \text{End } Z < \infty$. Now, the map $\text{Hom}(X, Y) \rightarrow \text{End } Z$ given by $s \mapsto v \circ s \circ u^*$ is injective since it has $t \mapsto v^* \circ t \circ u$ as inverse. This implies $\dim \text{Hom}(X, Y) < \infty$.

We omit the proof of the implication $TC^* \Rightarrow C^*$ -tensor category, since it will not be used in the sequel. It can be found in [Müger, 2000]. ■

This result shows that the assumptions made in Appendix B are equivalent to those of [Doplicher and Roberts, 1989], formulated in terms of C^* -tensor categories.

A.5 Abelian categories

In the second half of Appendix B, which is of a purely algebraic nature, we will need some basic facts from the theory of abelian categories. Good references are, e.g., [Gabriel, 1962] and [Mac Lane, 1998, Chapter VIII].

DEFINITION 347. A morphism $s : X \rightarrow Y$ is called monic if $s \circ t_1 = s \circ t_2$ implies $t_1 = t_2$, whenever t_1, t_2 are morphisms with target X and the same source. A morphism $s : X \rightarrow Y$ is called epi if $t_1 \circ s = t_2 \circ s$ implies $t_1 = t_2$, whenever t_1, t_2 are morphisms with source Y and the same target.

DEFINITION 348. Let \mathcal{C} be an additive category. Given a morphism $f : X \rightarrow Y$, a morphism $k : Z \rightarrow X$ is a kernel of f if $f \circ k = 0$ and given any morphism $k' : Z' \rightarrow X$ such that $f \circ k' = 0$, there is a unique morphism $l : Z' \rightarrow Z$ such that $k' = k \circ l$.

A cokernel of $f : X \rightarrow Y$ is a morphism $c : Y \rightarrow Z$ if $c \circ f = 0$ and given any morphism $c' : Y \rightarrow Z'$ such that $c' \circ f = 0$, there is a unique $d : Z \rightarrow Z'$ such that $c' = d \circ c$.

It is an easy consequence of the definition that every kernel is monic and every cokernel is epic.

DEFINITION 349. An additive category \mathcal{C} is *abelian* if

1. Every morphism has a kernel and a cokernel.
2. Every monic morphism is the kernel of some morphism.
3. Every epic morphism is the cokernel of some morphism.

PROPOSITION 350. Let \mathcal{C} be an abelian category. Then

- (i) Every monic is the kernel of its cokernel and every epi is the cokernel of its kernel.
- (ii) A morphism is an isomorphism iff it is monic and epic.
- (iii) Every morphism $f : X \rightarrow Y$ in an abelian category admits a factorization $f = m \circ e$, where $e : X \rightarrow Z$ is epi and $m : Z \rightarrow Y$ is monic. Given another epi $e' : X \rightarrow Z'$ and monic $m' : Z' \rightarrow Y$ such that $f = m' \circ e'$, there exists an isomorphism $u : Z \rightarrow Z'$ such that $e' = u \circ e$ and $m = m' \circ u$.

Proof. See [Mac Lane, 1998, Chapter VIII] for detailed proofs. The ‘only if’ of (ii) is trivial. Concerning (iii): Defining $m = \ker(\text{coker}(f))$, m is monic. In view of $(\text{coker } f) \circ f = 0$, f factors as $f = m \circ e$ for a unique e . Next one proves that e is epi and $e = \text{coker}(\ker(f))$. ■

DEFINITION 351. The *image* of a morphism $f : X \rightarrow Y$ in an abelian category is the monic $m : Z \rightarrow Y$ (unique up to isomorphism) in the monic-epic factorization $X \xrightarrow{e} Z \xrightarrow{m} Y$ of f .

In a concrete abelian category, the object Z is isomorphic to the usual image of f , which is a subset of Y , whence the terminology.

DEFINITION 352. An object P in an abelian category is *projective* if, given any epimorphism $p : A \rightarrow B$ and any morphism $b : P \rightarrow B$ there is a morphism $a : P \rightarrow A$ such that $b = p \circ a$.

LEMMA 353. Any TC^* \mathcal{C} that has a zero object is abelian.

Proof. It is clear that \mathcal{C} is additive. The other requirements of Definition 349 follow with a little work from semisimplicity, cf. Lemma 334. ■

A.6 Commutative algebra in abelian symmetric tensor categories

A considerable part of the well known algebra of commutative rings, their ideals and modules (living in the category Ab of abelian groups) can be generalized to other abelian symmetric or even braided tensor categories. We state just those facts that will be needed, some of which might be new.

DEFINITION 354. Let \mathcal{D} be a strict tensor category. Then a monoid in \mathcal{D} is a triple (Q, m, η) , where $Q \in \mathcal{D}$ and $m : Q \otimes Q \rightarrow Q$ and $\eta : \mathbf{1} \rightarrow Q$ are morphisms satisfying

$$m \circ (m \otimes \text{id}_Q) = m \circ (\text{id}_Q \otimes m), \quad m \circ \eta \otimes \text{id}_Q = \text{id}_Q = m \circ \text{id}_Q \otimes \eta.$$

If \mathcal{D} is braided then the monoid is called commutative if $m \circ c_{Q,Q} = m$.

DEFINITION 355. Let (Q, m, η) be a monoid in the strict tensor category \mathcal{D} . Then a Q -module (in \mathcal{D}) is a pair (M, μ) , where $M \in \mathcal{D}$ and $\mu : Q \otimes M \rightarrow M$ satisfy

$$\mu \circ \text{id}_Q \otimes \mu = \mu \circ m \otimes \text{id}_M, \quad \mu \circ \eta \otimes \text{id}_M = \text{id}_M.$$

A morphism $s : (M, \mu) \rightarrow (R, \rho)$ of Q -modules is a morphism $s \in \text{Hom}_{\mathcal{D}}(M, R)$ satisfying $s \circ \mu = \rho \circ \text{id}_Q \otimes s$. The Q -modules in \mathcal{D} and their morphisms form a category $Q\text{-Mod}_{\mathcal{D}}$. If \mathcal{D} is k -linear then $Q\text{-Mod}_{\mathcal{D}}$ is k -linear. The hom-sets in the category $Q\text{-Mod}$ are denoted by $\text{Hom}_Q(\cdot, \cdot)$.

REMARK 356.

1. The preceding definitions, which are obvious generalizations of the corresponding notions in Vect , generalize in a straightforward way to non-strict tensor categories.
2. If (M, μ) is a Q -module and $X \in \mathcal{D}$ then $(Q \otimes X, \mu \otimes \text{id}_X)$ is a Q -module.
3. If \mathcal{D} has direct sums, we can define the direct sum (R, ρ) of two Q -modules $(M_1, \mu_1), (M_2, \mu_2)$. Concretely, if $v_i : M_i \rightarrow R, i = 1, 2$ are the isometries corresponding to $R \cong M_1 \oplus M_2$ then $\rho = v_1 \circ \mu_1 \circ \text{id}_Q \otimes v_1^* + v_2 \circ \mu_2 \circ \text{id}_Q \otimes v_2^*$ provides a Q -module structure.
4. Given a monoid (Q, m, η) in \mathcal{D} , we have an obvious Q -module (Q, m) , and for any $n \in \mathbb{N}$ we can consider $n \cdot (Q, m)$, the direct sum of n copies of the Q -module (Q, m) .

DEFINITION 357. Let \mathcal{D} be a strict tensor category with unit $\mathbf{1}$ and let (Q, m, η) be a monoid in \mathcal{D} . We define a monoid Γ_Q in the category of sets by $\Gamma_Q = \text{Hom}(\mathbf{1}, Q)$, the multiplication being given by $s \bullet t = m \circ t \otimes s$ and the unit by η . If \mathcal{D} is braided and (Q, m, η) commutative then Γ_Q is commutative.

LEMMA 358. *Let \mathcal{D} be a strict tensor category and (Q, m, η) a monoid in \mathcal{D} . Then there is an isomorphism of monoids $\gamma : \text{End}_Q((Q, m)) \rightarrow (\Gamma_Q, \bullet, \eta)$ given by*

$$\begin{aligned} \gamma : \text{End}_Q((Q, m)) &\rightarrow \text{Hom}(\mathbf{1}, Q), & u &\mapsto u \circ \eta, \\ \gamma^{-1} : \text{Hom}(\mathbf{1}, Q) &\rightarrow \text{End}_Q((Q, m)), & s &\mapsto m \circ \text{id}_Q \otimes s. \end{aligned}$$

If \mathcal{D} (and thus $Q - \text{Mod}_{\mathcal{D}}$) is k -linear then γ is an isomorphism of k -algebras. If \mathcal{D} is braided and the monoid (Q, m, η) is commutative then the monoid (k -algebra) $(\Gamma_Q, \bullet, \eta)$, and therefore also $\text{End}_Q((Q, m))$, is commutative.

Proof. That $(\Gamma_Q, \bullet, \eta)$ is a monoid (resp. associative k -algebra) is immediate since (Q, m, η) is a monoid. For $s \in \text{Hom}(\mathbf{1}, Q)$ we have $\gamma(\gamma^{-1}(s)) = m \circ \text{id}_Q \otimes s \circ \eta = s$ by the monoid axioms. On the other hand, for $u \in \text{End}_Q((Q, m))$ we have

$$\gamma^{-1}(\gamma(u)) = m \circ \text{id}_Q \otimes (u \circ \eta) = m \circ \text{id}_Q \otimes u \circ \text{id}_Q \otimes \eta = u \circ m \circ \text{id}_Q \otimes \eta = u,$$

where the third equality is due to the fact that s is a Q -module map (cf. Definition 355). Clearly $\gamma(\text{id}_Q) = \eta$. Furthermore,

$$\begin{aligned} \gamma^{-1}(s) \circ \gamma^{-1}(t) &= (m \circ \text{id}_Q \otimes s) \circ (m \circ \text{id}_Q \otimes t) = m \circ m \otimes \text{id}_Q \circ \text{id}_Q \otimes t \otimes s \\ &= m \circ \text{id}_Q \otimes m \circ \text{id}_Q \otimes t \otimes s = \gamma^{-1}(s \bullet t). \end{aligned}$$

If \mathcal{D} is braided and the monoid (Q, m, η) is commutative then

$$s \bullet t = m \circ t \otimes s = m \circ c_{Q, Q} \circ s \otimes t = m \circ s \otimes t = t \bullet s,$$

where we used naturality of the braiding and commutativity of the monoid. ■

REMARK 359. 1. We have seen that a monoid (Q, m, η) in any abstract tensor category gives rise to a monoid $(\Gamma_Q, \bullet, \eta)$ that is concrete, i.e. lives in the category Sets. The latter has the cartesian product as a tensor product and any one-element set is a tensor unit $\mathbf{1}$. Thus for any $X \in \text{Sets}$, $\text{Hom}(\mathbf{1}, X)$ is in bijective correspondence to the elements of X . Therefore, if $\mathcal{D} = \text{Sets}$ then the monoids (Q, m, η) and $(\Gamma_Q, \bullet, \eta)$ are isomorphic. For this reason, we call Γ_Q the monoid of elements of Q even when \mathcal{D} is an abstract category.

2. The commutativity of $\text{End}_Q((Q, m))$ in the case of a commutative monoid (Q, m, η) in a braided tensor category \mathcal{D} has a very natural interpretation: If \mathcal{D} has coequalizers, which holds in any abelian category, then the category $Q - \text{Mod}_{\mathcal{D}}$ is again a tensor category and the Q -module (Q, m) is its unit object. In any tensor category with unit $\mathbf{1}$, $\text{End } \mathbf{1}$ is a commutative monoid (commutative k -algebra if \mathcal{D} is k -linear). This is the real reason why $\text{End}_Q((Q, m))$ is commutative. More is known: If \mathcal{D} is symmetric and Q abelian, then the tensor category $Q - \text{Mod}_{\mathcal{D}}$ is again symmetric. (In the braided case this need not be true, but $Q - \text{Mod}_{\mathcal{D}}$ always has a distinguished full subcategory that is braided.)

We now specialize to abelian categories.

PROPOSITION 360. *Let (Q, m, η) be a monoid in an abelian strict tensor category \mathcal{D} . Then the category $Q - \text{Mod}_{\mathcal{D}}$ is abelian.*

Proof. Omitted. (This is a nice exercise on abelian categories.) ■

DEFINITION 361. Let \mathcal{D} be an abelian strict symmetric tensor category. An *ideal* in a commutative monoid (Q, m, η) is a monic $j : (J, \mu_J) \rightarrow (Q, m)$ in the category $Q - \text{Mod}$. An ideal $j : (J, \mu_J) \rightarrow (Q, m)$ is called *proper* if j is not an isomorphism (i.e. not epi). If $j : (J, \mu_J) \rightarrow (Q, m)$ and $j' : (J', \mu_{J'}) \rightarrow (Q, m)$ are ideals then $j : (J, \mu_J) \rightarrow (Q, m)$ is *contained* in $j' : (J', \mu_{J'}) \rightarrow (Q, m)$, denoted $j < j'$, if there exists a monic $i \in \text{Hom}_Q((J, \mu_J), (J', \mu_{J'}))$ such that $j' \circ i = j$. A proper ideal $j : (J, \mu_J) \rightarrow (Q, m)$ in (Q, m, η) is called *maximal* if every proper ideal $j' : (J', \mu_{J'}) \rightarrow (Q, m)$ containing $j : (J, \mu_J) \rightarrow (Q, m)$ is isomorphic to $j : (J, \mu_J) \rightarrow (Q, m)$.

LEMMA 362. *Let \mathcal{D} be an essentially small abelian strict symmetric tensor category, (Q, m, η) a commutative monoid in \mathcal{D} . Then every proper ideal $j : (J, \mu_J) \rightarrow (Q, m)$ in (Q, m, η) is contained in a maximal ideal $\tilde{j} : (\tilde{J}, \tilde{\mu}) \rightarrow (Q, m)$.*

Proof. The ideals in (Q, m, η) do not necessarily form a set, but the isomorphism classes do, since \mathcal{D} is assumed essentially small. The relation $<$ on the ideals in (Q, m, η) gives rise to a partial ordering of the set of isomorphism classes of ideals. The maximal elements w.r.t. this partial order are precisely the isomorphism classes of maximal ideals. Now we can apply Zorn’s Lemma to complete the proof as in commutative algebra. ■

As in the category $R\text{-mod}$, we can quotient a commutative monoid by an ideal:

LEMMA 363. *Let \mathcal{D} be an abelian strict symmetric tensor category, (Q, m, η) a commutative monoid and $j : (J, \mu_J) \rightarrow (Q, m)$ an ideal. Let $p = \text{coker } j : (Q, m) \rightarrow (B, \mu_B)$. Then there exist unique morphisms $m_B : B \otimes B \rightarrow B$ and $\eta_B : \mathbf{1} \rightarrow B$ such that*

1. (B, m_B, η_B) is a commutative monoid,
2. $p \circ m = m_B \circ p \otimes p$,
3. $p \circ \eta = \eta_B$.

The monoid (B, m_B, η_B) is called the quotient of (Q, m, η) by the ideal $j : (J, \mu_J) \rightarrow (Q, m)$. It is nontrivial (B is not a zero object) iff the ideal is proper.

Furthermore, the map $p_\Gamma : \Gamma : \Gamma_Q \rightarrow \Gamma_B$ given by $s \mapsto p \circ s$ is a homomorphism of commutative algebras, which is surjective if the unit $\mathbf{1} \in \mathcal{D}$ is a projective object.

Proof. The construction of m_B, η_B proceeds essentially as in commutative algebra, despite the fact that the absence of elements makes it somewhat more abstract. Since $p : (Q, m) \rightarrow (B, \mu_B)$ is the cokernel of j , B is non-zero iff j is not epi, to wit if the ideal is proper. The equations $p \circ m = m_B \circ p \otimes p$ and $p \circ \eta = \eta_B$ imply that p_Γ is a unital homomorphism. If $\mathbf{1}$ is projective then the very Definition 352 implies that for every $s : \mathbf{1} \rightarrow B$ there is $t : \mathbf{1} \rightarrow Q$ such that $s = p \circ t$, thus p_Γ is surjective. ■

LEMMA 364. Let \mathcal{D} be an essentially small abelian strict symmetric tensor category. Let (Q, m, η) be a commutative monoid in \mathcal{D} and $j : (J, \mu) \rightarrow (Q, m)$ an ideal. Let (B, m_B, η_B) be the quotient monoid. Then there is a bijective correspondence between equivalence classes of ideals in (B, m_B, η_B) and equivalence classes of ideals $j' : (J', \mu') \rightarrow (Q, m)$ in (Q, μ, η) that contain $j : (J, \mu) \rightarrow (Q, m)$.

In particular, if j is a maximal ideal then all ideals in (B, m_B, η_B) are either zero or isomorphic to (B, m_B) .

Proof. As in ordinary commutative algebra. ■

LEMMA 365. Let k be a field and (Q, m, η) a commutative monoid in the strict symmetric abelian k -linear category \mathcal{D} . If every non-zero ideal in (Q, m, η) is isomorphic to (Q, m) then the commutative unital k -algebra $\text{End}_Q((Q, m))$ is a field.

Proof. Let $s \in \text{End}_Q((Q, m))$ be non-zero. Then $\text{im } s \neq 0$ is a non-zero ideal in (Q, m) , thus must be isomorphic to (Q, m) . Therefore $\text{im } s$ and in turn s are epi. Since $s \neq 0$, the kernel $\ker s$ is not isomorphic to (Q, m) and therefore it must be zero, thus s is monic. By Proposition 350, s is an isomorphism. Thus the commutative k -algebra $\text{End}_Q((Q, m))$ is a field extending k . ■

The following lemma is borrowed from [Bichon, 1998]:

LEMMA 366. Let \mathcal{D} be an abelian strict symmetric tensor category and (Q, m, η) a commutative monoid in it. Then every epimorphism in $\text{End}_Q((Q, m))$ is an isomorphism.

Proof. Let $g \in \text{End}_Q((Q, m))$ be an epimorphism and let $j : (J, \mu_J) \rightarrow (Q, m)$ be an ideal in (Q, m, η) . Now, $Q - \text{Mod}$ is a tensor category whose unit is (Q, m) , thus there is an isomorphism $s \in \text{Hom}_Q((J, \mu_J), (Q \otimes_Q J, \mu_{Q \otimes_Q J}))$. Let $h \in \text{End}_Q((J, \mu_J))$ be the composition

$$(J, \mu_J) \xrightarrow{s} (Q \otimes_Q J, \mu_{Q \otimes_Q J}) \xrightarrow{g \otimes \text{id}_J} (Q \otimes_Q J, \mu_{Q \otimes_Q J}) \xrightarrow{s^{-1}} (J, \mu_J).$$

Since the tensor product \otimes_Q of $Q - \text{Mod}$ is right-exact, $g \otimes \text{id}_J$ is epi. Now, $j \circ h = g \circ j$, and if we put $(j : (J, \mu_J) \rightarrow (Q, m)) = \ker g$ we have $j \circ h = 0$ and thus $j = 0$ since h is epi. Thus g is monic and therefore an isomorphism. ■

A.7 Inductive limits and the Ind-category

We need the categorical version of the concept of an inductive limit. For our purposes, inductive limits over \mathbb{N} will do, but in order to appeal to existing theories we need some definitions.

DEFINITION 367. If \mathcal{I}, \mathcal{C} are categories and $F : \mathcal{I} \rightarrow \mathcal{C}$ a functor, then a *colimit* (or *inductive limit*) of F consists of an object $Z \in \mathcal{C}$ and, for every $X \in \mathcal{I}$, of a morphism $i_X : F(X) \rightarrow Z$ in \mathcal{C} such that

1. $i_Y \circ F(s) = i_X$ for every morphism $s : X \rightarrow Y$ in \mathcal{I} .
2. Given $Z' \in \mathcal{C}$ and a family of morphisms $j_X : F(X) \rightarrow Z'$ in \mathcal{C} such that $j_Y \circ F(s) = j_X$ for every morphism $s : X \rightarrow Y$ in \mathcal{I} , there is a unique morphism $\iota : Z \rightarrow Z'$ such that $j_X = \iota \circ i_X$ for all $X \in \mathcal{I}$.

The second property required above is the universal property. It implies that any two colimits of F are isomorphic. Thus the colimit is essentially unique, provided it exists.

DEFINITION 368. A category \mathcal{I} is *filtered* if it is non-empty and

1. For any two objects $X, Y \in \mathcal{I}$ there is an $Z \in \mathcal{I}$ and morphisms $i : X \rightarrow Z, j : Y \rightarrow Z$.
2. For any two morphisms $u, v : X \rightarrow Y$ in \mathcal{I} there is a morphism $w : Y \rightarrow Z$ such that $w \circ u = w \circ v$.

Note that any directed partially ordered set (I, \leq) is a filtered category if we take the objects to be the elements of I , and the arrows are ordered pairs $\{(i, j) : i \leq j\}$.

DEFINITION 369. Let \mathcal{C} be a category. Then the category $\text{Ind } \mathcal{C}$ is defined as the functor category whose objects are all functors $F : \mathcal{I} \rightarrow \mathcal{C}$, where \mathcal{I} is a small filtered category. For $F : \mathcal{I} \rightarrow \mathcal{C}, F' : \mathcal{I}' \rightarrow \mathcal{C}$, the hom-set is defined by

$$\text{Hom}_{\text{Ind } \mathcal{C}}(F, F') = \varinjlim_x \varinjlim_y \text{Hom}_{\mathcal{C}}(F(X), F'(Y)).$$

(An element of the r.h.s. consists of a family $(f_{X,Y} : F(X) \rightarrow F'(Y))_{X \in \mathcal{I}, Y \in \mathcal{I}'}$ satisfying $F'(s) \circ f_{X,Y} = f_{X,Y'}$ for every $s : Y \rightarrow Y'$ in \mathcal{I}' and $f_{X',Y} \circ F(t) = f_{X,Y}$ for every $t : X \rightarrow X'$ in \mathcal{I} .) We leave it as an exercise to work out the composition of morphisms.

Some properties of $\text{Ind } \mathcal{C}$ are almost obvious. It contains \mathcal{C} as a subcategory: To every $X \in \mathcal{C}$ we assign the functor $F : \mathcal{I} \rightarrow \mathcal{C}$, where \mathcal{I} has only one object $*$ and $F(*) = X$. This embedding clearly is full and faithful. If \mathcal{C} is an Ab-category / additive / \mathbb{C} -linear then so is $\text{Ind } \mathcal{C}$. If \mathcal{C} is a strict (symmetric) tensor category then so is $\text{Ind } \mathcal{C}$: The tensor product of $F : \mathcal{I} \rightarrow \mathcal{C}$ and $F' : \mathcal{I}' \rightarrow \mathcal{C}$ is defined by $\mathcal{I}'' = \mathcal{I} \times \mathcal{I}'$ (which is a filtered category) and $F \otimes F' : \mathcal{I}'' \ni X \times Y \mapsto F(X) \otimes F'(Y)$. For the remaining results that we need, we just cite [SGA, 1972], to which we also refer for the proof:

THEOREM 370. *Ind \mathcal{C} has colimits for all small filtered index categories \mathcal{I} . If \mathcal{C} is an abelian category \mathcal{C} then $\text{Ind } \mathcal{C}$ is abelian.*

Thus every abelian (symmetric monoidal) category is a full subcategory of an abelian (symmetric monoidal) category that is complete under filtered colimits. For us this means that in $\text{Ind } \mathcal{C}$ we can make sense of infinite direct sums indexed by \mathbb{N} , defining $\bigoplus_{i \in \mathbb{N}} X_i$ as the colimit of the functor $F : \mathcal{I} \rightarrow \mathcal{C}$, where \mathcal{I} is the

poset \mathbb{N} interpreted as a filtered category, and $F(n) = \bigoplus_{i=1}^n X_i$ together with the obvious morphisms $F(n) \rightarrow F(m)$ when $n \leq m$.

LEMMA 371. *If \mathcal{C} is a TC^* then every object $X \in \mathcal{C}$ is projective as an object of $\text{Ind } \mathcal{C}$.*

Proof. First assume that X is irreducible and consider $s : X \rightarrow B$. Given an epi $p : A \rightarrow B$ in $\text{Ind } \mathcal{C}$, we have $A = \lim_{\leftarrow} A_i$ with $A_i \in \mathcal{C}$ and similarly for B . Furthermore, $\text{Hom}(A, B) = \lim_{\leftarrow} \lim_{\leftarrow} \text{Hom}_{\mathcal{C}}(A_i, B_j)$ and $\text{Hom}(X, B) = \lim_{\leftarrow} \text{Hom}_{\mathcal{C}}(X, B_j)$. Since X is irreducible and \mathcal{C} is semisimple, X is a direct summand of B_j whenever $s_j : X \rightarrow B_j$ is non-zero. Since $p : A \rightarrow B$ is epi, the component $A_i \rightarrow B_j$ is epi for i sufficiently big. By semisimplicity of \mathcal{C} , s_j then lifts to a morphism $X \rightarrow A_i$. Putting everything together this gives a morphism $\widehat{s} : X \rightarrow A$ such that $p \circ \widehat{s} = s$.

Now let X be a finite direct sum of irreducible X_i with isometries $v_i : X_i \rightarrow X$ and $s : X \rightarrow B$. Defining $s_i = s \circ v_i : X_i \rightarrow B$, the first half of the proof provides $\widehat{s}_i : X_i \rightarrow A$ such that $p \circ \widehat{s}_i = s_i$. Now define $\widehat{s} = \sum_i \widehat{s}_i \circ v_i^* : X \rightarrow A$. We have

$$p \circ \widehat{s} = \sum_i p \circ \widehat{s}_i \circ v_i^* = \sum_i s_i \circ v_i^* = \sum_i s \circ v_i \circ v_i^* = s,$$

proving projectivity of X . ■

B ABSTRACT DUALITY THEORY FOR SYMMETRIC TENSOR *-CATEGORIES

In the first two subsections we give self-contained statements of the results needed for the reconstructions in AQFT. Some of the proofs are deferred to the rest of this appendix, which hurried (or less ambitious) or readers may safely skip.

B.1 Fiber functors and the concrete Tannaka theorem. Part I

Let $\text{Vect}_{\mathbb{C}}$ denote the \mathbb{C} -linear symmetric tensor category of finite dimensional \mathbb{C} -vector spaces and \mathcal{H} denote the STC^* of finite dimensional Hilbert spaces. We pretend that both tensor categories are strict, which amounts to suppressing the associativity and unit isomorphisms α, λ, ρ from the notation. Both categories have a canonical symmetry Σ , the flip isomorphism $\Sigma_{V, V'} : V \otimes V' \rightarrow V' \otimes V$.

DEFINITION 372. Let \mathcal{C} be an STC^* . A fiber functor for \mathcal{C} is a faithful \mathbb{C} -linear tensor functor $E : \mathcal{C} \rightarrow \text{Vect}_{\mathbb{C}}$. A $*$ -preserving fiber functor for \mathcal{C} is a faithful functor $E : \mathcal{C} \rightarrow \mathcal{H}$ of tensor $*$ -categories. E is symmetric if $E(c_{X, Y}) = \Sigma_{E(X), E(Y)}$, i.e. the symmetry of \mathcal{C} is mapped to the canonical symmetry of $\text{Vect}_{\mathbb{C}}$ or \mathcal{H} , respectively.

An STC^* equipped with a symmetric $*$ -preserving fiber functor is called concrete, since it is equivalent to a (non-full!) tensor subcategory of the category \mathcal{H} of Hilbert spaces. Our main concern in this appendix are (1) Consequences of the

existence of a fiber functor, (2) Uniqueness of fiber functors, and (3) Existence of fiber functors. As to (2) we will prove:

THEOREM 373. *Let \mathcal{C} be an STC^* and let $E_1, E_2 : \mathcal{C} \rightarrow \mathcal{H}$ be $*$ -preserving symmetric fiber functors. Then $E_1 \cong E_2$, i.e. there exists a unitary monoidal natural isomorphism $\alpha : E_1 \rightarrow E_2$.*

We now *assume* a symmetric $*$ -preserving fiber functor for the STC^* \mathcal{C} to be given. Let $G_E \subset \text{Nat}_{\otimes} E$ denote the set of unitary monoidal natural transformations of E (to itself). This clearly is a group with the identical natural transformation as unit. G_E can be identified with a subset of $\prod_{X \in \mathcal{C}} \mathcal{U}(E(X))$, where $\mathcal{U}(E(X))$ is the compact group of unitaries on the finite dimensional Hilbert space $E(X)$. The product of these groups is compact by Tychonov's theorem, cf. e.g. [Pedersen, 1989, Theorem 1.6.10], and since G_E is a closed subset, it is itself compact. The product and inverse maps are continuous, thus G_E is a compact topological group. By its very definition, the group G_E acts on the Hilbert spaces $E(X), X \in \mathcal{C}$ by unitary representations π_X , namely $\pi_X(g) = g_X$ where g_X is the component at X of the natural transformation $g \in G_E$.

PROPOSITION 374. *There is a faithful symmetric tensor $*$ -functor $F : \mathcal{C} \rightarrow \text{Rep}_f G_E$ such that $K \circ F = E$, where $K : \text{Rep}_f G_E \rightarrow \mathcal{H}$ is the forgetful functor $(H, \pi) \mapsto H$.*

Proof. We define $F(X) = (E(X), \pi_X) \in \text{Rep}_f G_E$ for all $X \in \mathcal{C}$ and $F(s) = E(s)$ for all $s \in \text{Hom}(X, Y)$. For $s : X \rightarrow Y$ we have

$$F(s)\pi_X(g) = F(s)g_X = g_Y F(s) = \pi_Y(g)F(s),$$

since $g : E \rightarrow E$ is a natural transformation. Thus F is a functor, which is obviously $*$ -preserving and faithful. In view of $g_{\mathbf{1}} = \text{id}_{E(\mathbf{1})}$ for every $g \in G_E$, we have $F(\mathbf{1}_{\mathcal{C}}) = (\mathbb{C}, \pi_0) = \mathbf{1}_{\text{Rep}_f G_E}$, where π_0 is the trivial representation. In order to see that F is a functor of tensor $*$ -categories we must produce unitaries $d_{X,Y}^F : F(X) \otimes F(Y) \rightarrow F(X \otimes Y)$, $X, Y \in \mathcal{C}$ and $e : \mathbf{1}_{\text{Rep}_f G_E} \rightarrow F(\mathbf{1}_{\mathcal{C}})$ satisfying (56) and (57), respectively. We claim that the choice $e^F = e^E$, $d_{X,Y}^F = d_{X,Y}^E$ does the job, where the e^E and $d_{X,Y}^E$ are the unitaries coming with the tensor functor $E : \mathcal{C} \rightarrow \mathcal{H}$. It is obvious that e^E and $d_{X,Y}^E$ satisfy (56) and (57), but we must show that they are morphisms in $\text{Rep}_f G_E$. For $d_{X,Y}^E$ this follows from the computation

$$d_{X,Y}^F \circ (\pi_X(g) \otimes \pi_Y(g)) = d_{X,Y}^E \circ g_X \otimes g_Y = g_{X \otimes Y} \circ d_{X,Y}^E = \pi_{X \otimes Y}(g) \circ d_{X,Y}^F,$$

where we have used that g is a monoidal natural transformation. Now, by the definition of a natural monoidal transformation we have $g_{\mathbf{1}} = \text{id}_{E(\mathbf{1})}$ for all $g \in G_E$, i.e. $F(\mathbf{1}) = (E(\mathbf{1}), \pi_{\mathbf{1}})$ is the trivial representation. If the strict unit $\mathbf{1}_{\mathcal{H}} = \mathbb{C}$ is in the image of E then, by naturality, it also carries the trivial representation, thus e^F in fact is a morphism of representations. (In case $\mathbf{1}_{\mathcal{H}} \notin E(\mathcal{C})$, we equip $\mathbf{1}_{\mathcal{H}}$ with the trivial representation by hand.) Since the symmetry of $\text{Rep}_f G_E$ is by definition given by $c((H, \pi), (H', \pi')) = c(H, H')$, where the right hand side refers

to the category \mathcal{H} , and since E respects the symmetries, so does F . $K \circ F = E$ is obvious. ■

The proof of the following proposition is postponed, since it requires further preparations.

PROPOSITION 375. *Let \mathcal{C} be an STC^* and $E : \mathcal{C} \rightarrow \mathcal{H}$ a symmetric $*$ -preserving fiber functor. Let G_E and $F : \mathcal{C} \rightarrow \text{Rep}_f G_E$ as defined above. Then the following hold:*

- (i) *If $X \in \mathcal{C}$ is irreducible then $\text{span}_{\mathbb{C}}\{\pi_X(g), g \in G_E\}$ is dense in $\text{End } E(X)$.*
- (ii) *If $X, Y \in \mathcal{C}$ are irreducible and $X \not\cong Y$ then $\text{span}_{\mathbb{C}}\{\pi_X(g) \oplus \pi_Y(g), g \in G_E\}$ is dense in $\text{End } E(X) \oplus \text{End } E(Y)$.*

THEOREM 376. *Let \mathcal{C} be an STC^* and $E : \mathcal{C} \rightarrow \mathcal{H}$ a symmetric $*$ -preserving fiber functor. Let G_E and $F : \mathcal{C} \rightarrow \text{Rep}_f G_E$ as defined above. Then F is an equivalence of symmetric tensor $*$ -categories.*

Proof. We already know that F is a faithful symmetric tensor functor. In view of Proposition 318 it remains to show that F is full and essentially surjective.

Since the categories \mathcal{C} and $\text{Rep}_f G_E$ are semisimple, in order to prove that F is full it is sufficient to show that (a) $F(X) \in \text{Rep}_f G_E$ is irreducible if $X \in \mathcal{C}$ is irreducible and (b) whenever $X, Y \in \mathcal{C}$ are irreducible and inequivalent then $\text{Hom}(F(X), F(Y)) = \{0\}$. Now, (i) of Proposition 375 clearly implies that $\text{End}(F(X)) = \mathbb{C} \text{id}$, which is the desired irreducibility of $F(X)$. Assume now that $X, Y \in \mathcal{C}$ are irreducible and non-isomorphic and let $s \in \text{Hom}(F(X), F(Y))$, to wit $s \in \text{Hom}(E(X), E(Y))$ and $s\pi_X(g) = \pi_Y(g)s$ for all $g \in G_E$. Then (ii) of Proposition 375 implies $su = vs$ for any $u \in \text{End } E(X)$ and $v \in \text{End } E(Y)$. With $u = 0$ and $v = 1$ this implies $s = 0$, thus the irreps $F(X) = (E(X), \pi_X)$ and $F(Y) = (E(X), \pi_Y)$ are non-isomorphic. This proves that F is full.

Therefore, F is an equivalence of \mathcal{C} with a full tensor subcategory of $\text{Rep}_f G_E$. If $g \in G_E$ is nontrivial, it is immediate by the definition of G_E that there is an $X \in \mathcal{C}$ such that $g_X \neq \text{id}_{E(X)}$ – but this means $\pi_X(g) \neq \mathbf{1}$. In other words, the representations $\{F(X), X \in \mathcal{C}\}$ separate the points of G_E . But it is a well known consequence of the Peter-Weyl theorem that a full monoidal subcategory of $\text{Rep}_f G_E$ separates the points of G_E iff it is in fact equivalent to $\text{Rep}_f G_E$. Thus the functor F is essentially surjective, and we are done. ■

Since they are so important, we restate Theorems 373 and 376 in a self contained way:

THEOREM 377. *Let \mathcal{C} be an STC^* and $E : \mathcal{C} \rightarrow \mathcal{H}$ a $*$ -preserving symmetric fiber functor. Let G_E be the group of unitary monoidal natural transformations of E with the topology inherited from $\prod_{X \in \mathcal{C}} \mathcal{U}(E(X))$. Then G_E is compact and the functor $F : \mathcal{C} \rightarrow \text{Rep}_f G_E, X \mapsto (E(X), \pi_X)$, where $\pi_X(g) = g_X$, is an equivalence*

of STC^* s. If $E_1, E_2 : \mathcal{C} \rightarrow \mathcal{H}$ are $*$ -preserving symmetric fiber functors then $E_1 \cong E_2$ and therefore $G_{E_1} \cong G_{E_2}$.

REMARK 378. The preceding theorem is essentially a reformulation in modern language of the classical result of Tannaka [Tannaka, 1939]. It can be generalized, albeit without the uniqueness part, to a setting where \mathcal{C} is only braided or even has no braiding. This leads to a (concrete) Tannaka theory for quantum groups, for which the interested reader is referred to the reviews [Joyal and Street, 1991] and [Müger *et al.*, 2004].

Before we turn to proving Theorem 373 (Subsection B.4) and Proposition 375 (Subsection B.5) we identify a necessary condition for the existence of fiber functors, which will lead us to a generalization of Theorem 377.

B.2 Compact supergroups and the abstract Tannaka theorem

According to Theorem 377, an STC^* admitting a symmetric $*$ -preserving fiber functor is equivalent, as a symmetric tensor $*$ -category, to the category of finite dimensional unitary representations of a compact group G that is uniquely determined up to isomorphism. Concerning the existence of fiber functors it will turn out that the twist Θ (Definition 342) provides an obstruction, fortunately the only one.

DEFINITION 379. An STC^* is called even if $\Theta(X) = \text{id}_X$ for all $X \in \mathcal{C}$.

EXAMPLE 380. A simple computation using the explicit formulae for $r, \bar{r}, c_{X,Y}$ given in Example 333 shows that the STC^* \mathcal{H} of finite dimensional Hilbert spaces is even. The same holds for the category $\text{Rep}_f G$ of finite dimensional unitary representations of a compact group G .

This suggests that an STC^* must be even in order to admit a fiber functor. In fact:

PROPOSITION 381. If an STC^* \mathcal{C} admits a $*$ -preserving symmetric fiber functor E then it is even.

Proof. By Proposition 344, we have $E(\Theta(X)) = \Theta(E(X))$. Since \mathcal{H} is even, this equals $\text{id}_{E(X)} = E(\text{id}_X)$. Since E is faithful, this implies $\Theta(X) = \text{id}_X$. ■

Fortunately, this is the only obstruction since, beginning in the next subsection, we will prove:

THEOREM 382. Every even STC^* admits a $*$ -preserving symmetric fiber functor $E : \mathcal{C} \rightarrow \mathcal{H}$.

Combining this with Theorem 377 we obtain:

THEOREM 383. Let \mathcal{C} be an even STC^* . Then there is a compact group G , unique up to isomorphism, such that there exists an equivalence $F : \mathcal{C} \rightarrow \text{Rep}_f G$ of STC^* s.

Theorem 383 is not yet sufficiently general for the application to quantum field theory, which is the subject of this chapter. Making the connection with DHR theory, we see that the twist of an irreducible DHR sector is ± 1 , depending on whether the sector is bosonic or fermionic. Since in general we cannot a priori rule out fermionic sectors, we cannot restrict ourselves to even STC^* s. What we therefore really need is a characterization of all STC^* s. This requires a generalization of the notion of compact groups:

DEFINITION 384. A (compact) supergroup is a pair (G, k) where G is a (compact Hausdorff) group and k is an element of order two in the center of G . An isomorphism $\alpha : (G, k) \xrightarrow{\cong} (G', k')$ of (compact) supergroups is an isomorphism $\alpha : G \rightarrow G'$ of (topological) groups such that $\alpha(k) = k'$.

DEFINITION 385. A (finite dimensional, unitary, continuous) representation of a compact supergroup (G, k) is just a (finite dimensional, unitary, continuous) representation (H, π) of G . Intertwiners and the tensor product of representations are defined as for groups, thus $\text{Rep}_{(f)}(G, k) \cong \text{Rep}_{(f)}G$ as C^* -tensor categories. (Since k is in the center of G , morphisms in $\text{Rep}_{(f)}(G, k)$ automatically preserve the \mathbb{Z}_2 -grading induced by $\pi(k)$. $\text{Rep}_{(f)}(G, k)$ is equipped with a symmetry Σ_k as follows: For every $(H, \pi) \in \text{Rep}(G, k)$ let $P_{\pm} = (\text{id} + \pi(k))/2$ be the projector on the even and odd subspaces of a representation space H , respectively. Then

$$\Sigma_k((H, \pi), (H', \pi')) = \Sigma(H, H')(\mathbf{1} - 2P_{-}^{\pi} \otimes P_{-}^{\pi'}),$$

where $\Sigma(H, H') : H \otimes H' \rightarrow H' \otimes H$ is the usual flip isomorphism $x \otimes y \mapsto y \otimes x$. Thus for homogeneous $x \in H, y \in H'$ we have $\Sigma_k((H, \pi), (H', \pi')) : x \otimes y \mapsto \pm y \otimes x$, where the minus sign occurs iff $x \in H_{-}$ and $y \in H'_{-}$. In the case $(G, k) = (\{e, k\}, k)$, we call $\text{Rep}_f(G, k)$ the category \mathcal{SH} of super Hilbert spaces.

REMARK 386. Note that the action of k induces a \mathbb{Z}_2 -grading on H that is stable under the G -action. Since the symmetry Σ_k defined above is precisely the one on the category \mathcal{SH} of finite dimensional super Hilbert spaces, we see that there is a forgetful symmetric tensor functor $\text{Rep}_f(G, k) \rightarrow \mathcal{SH}$.

LEMMA 387. Σ_k as defined above is a symmetry on the category $\text{Rep}(G, k)$. Thus $\text{Rep}_f(G, k)$ is a STC^* . For every object $X = (H, \pi) \in \text{Rep}_f(G, k)$, the twist $\Theta(X)$ is given by $\pi(k)$.

Proof. Most of the claimed properties follow immediately from those of Rep_fG . It is clear that $\Sigma_k((H, \pi), (H', \pi')) \circ \Sigma_k((H', \pi'), (H, \pi))$ is the identity of $H' \otimes H$. We only need to prove naturality and compatibility with the tensor product. This is an easy exercise. The same holds for the identity $\Theta((H, \pi)) = \pi(k)$. ■

We need a corollary of (the proof of) Theorem 383:

COROLLARY 388. For any compact group G , the unitary monoidal natural transformations of the identity functor on Rep_fG form an abelian group that is isomorphic to the center $Z(G)$.

Proof. If $k \in Z(G)$ and $(H, \pi) \in \text{Rep}_f G$ is irreducible then $\pi(k) = \omega_{(H, \pi)} \text{id}_H$, where $\omega_{(H, \pi)}$ is a scalar. Defining $\Theta((H, \pi)) = \omega_{(H, \pi)} \text{id}_{(H, \pi)}$ and extending to reducible objects defines a unitary monoidal natural isomorphism of $\text{Rep}_f G$. Conversely, let $\{\Theta((H, \pi))\}$ be a unitary monoidal isomorphism of the identity functor of $\text{Rep}_f G$ and $K : \text{Rep}_f G \rightarrow \mathcal{H}$ the forgetful functor. Then the family $(\alpha_{(H, \pi)} = K(\Theta((H, \pi))))$ is a unitary monoidal natural isomorphism of K . By Theorem 377, there is a $g \in G$ such that $\alpha_{(H, \pi)} = \pi(g)$ for all $(H, \pi) \in \text{Rep}_f G$. Since $\pi(g)$ is a multiple of the identity for every irreducible (H, π) , g is in $Z(G)$ by Schur’s lemma. Clearly the above correspondence is an isomorphism of abelian groups. ■

Modulo Theorem 382 we can now prove the Main Result of this appendix:

THEOREM 389. *Let \mathcal{C} be an STC^* . Then there exist a compact supergroup (G, k) , unique up to isomorphism, and an equivalence $F : \mathcal{C} \rightarrow \text{Rep}_f(G, k)$ of symmetric tensor $*$ -categories. In particular, if $K : \text{Rep}_f(G, k) \rightarrow \mathcal{SH}$ is the forgetful functor, the composite $E = K \circ F : \mathcal{C} \rightarrow \mathcal{SH}$ is a ‘super fiber functor’, i.e. a faithful symmetric $*$ -preserving tensor functor into the STC^* of super Hilbert spaces.*

Proof. We define a new STC^* $\tilde{\mathcal{C}}$ (the ‘bosonization’ of \mathcal{C}) as follows. As a tensor $*$ -category, $\tilde{\mathcal{C}}$ coincides with \mathcal{C} . The symmetry \tilde{c} is defined by

$$\tilde{c}_{X, Y} = (-1)^{(1-\Theta(X))(1-\Theta(Y))/4} c_{X, Y}$$

for irreducible $X, Y \in \text{Obj } \mathcal{C} = \text{Obj } \tilde{\mathcal{C}}$, and extended to all objects by naturality. It is easy to verify that $(\tilde{\mathcal{C}}, \tilde{c})$ is again a symmetric tensor category, in fact an even one. Thus by Theorem 383 there is a compact group G such that $\tilde{\mathcal{C}} \simeq \text{Rep}_f G$ as STC^* s. Applying Corollary 388 to the category $\tilde{\mathcal{C}} \simeq \text{Rep}_f G$ and the family $(\Theta(X))_{X \in \mathcal{C}}$, as defined in the original category \mathcal{C} proves the existence of an element $k \in Z(G), k^2 = e$, such that $\Theta((H, \pi)) = \pi(k)$ for all $(H, \pi) \in \tilde{\mathcal{C}} \simeq \text{Rep}_f G$. Clearly (G, k) is a supergroup. We claim that $\mathcal{C} \simeq \text{Rep}_f(G, k)$ as STC^* s. Ignoring the symmetries this is clearly true since $\text{Rep}_f(G, k) \simeq \text{Rep}_f G$ as tensor $*$ -categories. That \mathcal{C} and $\text{Rep}_f(G, k)$ are equivalent as STC^* s, i.e. taking the symmetries into account, follows from the fact that \mathcal{C} is related to $\tilde{\mathcal{C}}$ precisely as $\text{Rep}_f(G, k)$ is to $\text{Rep}_f G$, namely by a twist of the symmetry effected by the family $(\Theta((H, \pi)) = \pi(k))$. To conclude, we observe that the uniqueness result for (G, k) follows from the uniqueness of G in Theorem 383 and that of k in Corollary 388. ■

REMARK 390. Theorem 389 was proven by Doplicher and Roberts in [Doplicher and Roberts, 1989, Section 7] exactly as stated above, the only superficial difference being that the terminology of supergroups wasn’t used. (Note that our supergroups are not what is usually designated by this name.) As above, the proof was by

reduction to even categories and compact groups. Independently and essentially at the same time, a result analogous to Theorem 382 for (pro)algebraic groups was proven by Deligne in [Deligne, 1990], implying an algebraic analogue of Theorem 383 by [Saavedra Rivano, 1972; Deligne and Milne, 1982]. Recently, Deligne also discussed the super case, cf. [Deligne, 2002].

This concludes the discussion of the main results of this appendix. We now turn to proving Theorem 373, Proposition 375 and Theorem 382.

B.3 Certain algebras arising from fiber functors

Let \mathcal{C} be a TC^* and $E_1, E_2 : \mathcal{C} \rightarrow \text{Vect}_{\mathbb{C}}$ fiber functors. Recall that they come with natural isomorphisms $d_{X,Y}^i : E_i(X) \otimes E_i(Y) \rightarrow E_i(X \otimes Y)$ and $e^i : \mathbf{1}_{\text{Vect}} = \mathbb{C} \rightarrow E_i(\mathbf{1}_{\mathcal{C}})$. Consider the \mathbb{C} -vector space

$$A_0(E_1, E_2) = \bigoplus_{X \in \mathcal{C}} \text{Hom}(E_2(X), E_1(X)).$$

For $X \in \mathcal{C}$ and $s \in \text{Hom}(E_2(X), E_1(X))$ we write $[X, s]$ for the element of $A_0(E_1, E_2)$ which takes the value s at X and is zero elsewhere. Clearly, A_0 consists precisely of the finite linear combinations of such elements. We turn $A_0(E_1, E_2)$ into a \mathbb{C} -algebra by defining $[X, s] \cdot [Y, t] = [X \otimes Y, u]$, where u is the composite

$$E_2(X \otimes Y) \xrightarrow{(d_{X,Y}^2)^{-1}} E_2(X) \otimes E_2(Y) \xrightarrow{s \otimes t} E_1(X) \otimes E_1(Y) \xrightarrow{d_{X,Y}^1} E_1(X \otimes Y)$$

Since \mathcal{C} is strict, we have $(X \otimes Y) \otimes Z = X \otimes (Y \otimes Z)$ and $\mathbf{1} \otimes X = X = X \otimes \mathbf{1}$. Together with the 2-cocycle type equation (56) satisfied by the isomorphisms $d_{X,Y}^i$ this implies that $A_0(E_1, E_2)$ is associative. The compatibility (57) of $d_{X,Y}^i$ with e^i for $i = 1, 2$ implies that $[\mathbf{1}, e^1 \circ (e^2)^{-1}]$ is a unit of the algebra $A_0(E_1, E_2)$.

LEMMA 391. *Let \mathcal{C} be a TC^* and $E_1, E_2 : \mathcal{C} \rightarrow \text{Vect}_{\mathbb{C}}$ fiber functors. The subspace*

$$I(E_1, E_2) = \text{span}_{\mathbb{C}}\{[X, a \circ E_2(s)] - [Y, E_1(s) \circ a] \mid s : X \rightarrow Y, a : E_2(Y) \rightarrow E_1(X)\}$$

is a two-sided ideal.

Proof. To show that $I(E_1, E_2) \subset A_0(E_1, E_2)$ is an ideal, let $s : X \rightarrow Y$, $a \in \text{Hom}(E_2(Y), E_1(X))$, thus $[X, a \circ E_2(s)] - [Y, E_1(s) \circ a] \in I(E_1, E_2)$, and let $[Z, t] \in A_0(E_1, E_2)$. Then

$$\begin{aligned} & ([X, a \circ E_2(s)] - [Y, E_1(s) \circ a]) \cdot [Z, t] \\ &= [X \otimes Z, d_{X,Z}^1 \circ (a \circ E_2(s)) \otimes t \circ (d_{X,Z}^2)^{-1}] \\ &\quad - [Y \otimes Z, d_{Y,Z}^1 \circ (E_1(s) \circ a) \otimes t \circ (d_{Y,Z}^2)^{-1}] \\ &= [X \otimes Z, d_{X,Z}^1 \circ a \otimes t \circ (d_{Y,Z}^2)^{-1} \circ E_2(s \otimes \text{id}_Z)] \\ &\quad - [Y \otimes Z, E_1(s \otimes \text{id}_Z) \circ d_{X,Z}^1 \circ a \otimes t \circ (d_{Y,Z}^2)^{-1}] \\ &= [X', a' \circ E_2(s')] - [Y', E_1(s') \circ a'] \in I(E_1, E_2), \end{aligned}$$

where in the second equality we used naturality of d^i , and in the last line we wrote $X' = X \otimes Z, Y' = Y \otimes Z, s' = s \otimes \text{id}_Z : X' \rightarrow Y'$ and $a' = d_{X,Z}^1 \circ a \otimes t \circ (d_{Y,Z}^2)^{-1} \in \text{Hom}(E_2(Y'), E_1(X'))$ in order to make clear that the result is in $I(E_1, E_2)$. This proves that the latter is a left ideal in $A_0(E_1, E_2)$. Similarly, one shows that it is a right ideal. ■

We denote by $A(E_1, E_2)$ the quotient algebra $A_0(E_1, E_2)/I(E_1, E_2)$. It can also be understood as the algebra generated by symbols $[X, s]$, where $X \in \mathcal{C}, s \in \text{Hom}(E_2(X), E_1(X))$, subject to the relations $[X, s] + [X, t] = [X, s + t]$ and $[X, a \circ E_2(s)] = [Y, E_1(s) \circ a]$ whenever $s : X \rightarrow Y, a \in \text{Hom}(E_2(Y), E_1(X))$. Therefore it should not cause confusion that we denote the image of $[X, s] \in A_0(E_1, E_2)$ in $A(E_1, E_2)$ again by $[X, s]$.

PROPOSITION 392. *Let \mathcal{C} be an STC* and $E_1, E_2 : \mathcal{C} \rightarrow \text{Vect}_{\mathbb{C}}$ fiber functors. If E_1, E_2 are symmetric then $A(E_1, E_2)$ is commutative.*

Proof. Assume that \mathcal{C} is symmetric and that the fiber functors satisfy $E_i(c_{X,Y}) = \Sigma_{E_i(X), E_i(Y)}$. Let $[A, u], [B, v] \in A_0(E_1, E_2)$, thus $A, B \in \mathcal{C}$ and $u : E_2(A) \rightarrow E_1(A), v : E_2(B) \rightarrow E_1(B)$. Then

$$[A, u] \cdot [B, v] = [A \otimes B, d_{A,B}^1 \circ u \otimes v \circ (d_{A,B}^2)^{-1}]$$

and

$$\begin{aligned} [B, v] \cdot [A, u] &= [B \otimes A, d_{B,A}^1 \circ v \otimes u \circ (d_{B,A}^2)^{-1}] \\ &= [B \otimes A, d_{B,A}^1 \circ \Sigma_{E_1(A), E_2(B)} \circ u \otimes v \circ \Sigma_{E_2(B), E_1(A)} \circ (d_{B,A}^2)^{-1}] \\ &= [B \otimes A, d_{B,A}^1 \circ E_1(c_{B,A}) \circ u \otimes v \circ E_2(c_{B,A}) \circ (d_{B,A}^2)^{-1}] \\ &= [B \otimes A, E_1(c_{A,B}) \circ d_{A,B}^1 \circ u \otimes v \circ (d_{A,B}^2)^{-1} \circ E_2(c_{B,A})]. \end{aligned}$$

With $X = A \otimes B, Y = B \otimes A, s = c_{A,B}$ and $a = d_{A,B}^1 \circ u \otimes v \circ (d_{A,B}^2)^{-1} \circ E_2(c_{B,A})$ we obtain

$$[A, u] \cdot [B, v] = [X, a \circ E_2(s)],$$

$$[B, v] \cdot [A, u] = [Y, E_1(s) \circ a].$$

Thus

$$[A, u] \cdot [B, v] - [B, v] \cdot [A, u] = [X, a \circ E_2(s)] - [Y, E_1(s) \circ a] \in I(E_1, E_2),$$

implying $[A_0(E_1, E_2), A_0(E_1, E_2)] \subset I(E_1, E_2)$. This implies commutativity of $A(E_1, E_2) = A_0(E_1, E_2)/I(E_1, E_2)$. ■

PROPOSITION 393. *Let \mathcal{C} be a TC* and let $E_1, E_2 : \mathcal{C} \rightarrow \mathcal{H}$ be *-preserving fiber functors. Then $A(E_1, E_2)$ has a positive *-operation, i.e. an antilinear and antimultiplicative involution such that $a^*a = 0$ implies $a = 0$.*

Proof. We define a $*$ -operation \star on $A_0(E_1, E_2)$. Let $[X, s] \in A_0(E_1, E_2)$. Pick a standard conjugate $(\bar{X}_i, r_i, \bar{r}_i)$, define $t \in \text{Hom}_{\mathcal{H}}(E_2(\bar{X}), E_1(\bar{X}))$ by

$$t = \text{id}_{E_1(\bar{X})} \otimes E_2(\bar{r}^*) \circ \text{id}_{E_1(\bar{X})} \otimes s^* \otimes \text{id}_{E_2(\bar{X})} \circ E_1(r) \otimes \text{id}_{E_2(\bar{X})}$$

and put $[X, s]^* := [\bar{X}, t]$. (Of course, s^* is defined using the inner products on the Hilbert spaces $E_1(X), E_2(X)$.) If we pick another standard conjugate (\bar{X}', r', \bar{r}') of X , we know that there is a unitary $u : \bar{X} \rightarrow \bar{X}'$ such that $r' = u \otimes \text{id}_X \circ r$ and $\bar{r}' = \text{id}_X \otimes u \circ \bar{r}$. Using (\bar{X}', r', \bar{r}') we obtain $([X, s]^*)' := [\bar{X}', t']$ with t' defined by replacing r, \bar{r} by r', \bar{r}' . Now, $[\bar{X}, t] - [\bar{X}', t']$ equals

$$\begin{aligned} & [\bar{X}, \text{id}_{E_1(\bar{X})} \otimes E_2(\bar{r}^*) \circ \text{id}_{E_1(\bar{X})} \otimes s^* \otimes \text{id}_{E_2(\bar{X})} \circ E_1(r) \otimes \text{id}_{E_2(\bar{X})}] \\ & - [\bar{X}', \text{id}_{E_1(\bar{X}')} \otimes E_2(\bar{r}'^*) \circ \text{id}_{E_1(\bar{X}')} \otimes s^* \otimes \text{id}_{E_2(\bar{X}')} \circ E_1(r') \otimes \text{id}_{E_2(\bar{X}')}] \\ & = [\bar{X}, (\text{id}_{E_1(\bar{X})} \otimes E_2(\bar{r}'^*) \circ \text{id}_{E_1(\bar{X})} \otimes s^* \otimes \text{id}_{E_2(\bar{X}')} \circ E_1(r) \otimes \text{id}_{E_2(\bar{X}')}) \circ E_2(u)] \\ & - [\bar{X}', E_1(u) \circ (\text{id}_{E_1(\bar{X})} \otimes E_2(\bar{r}'^*) \circ \text{id}_{E_1(\bar{X})} \otimes s^* \otimes \text{id}_{E_2(\bar{X}')}) \circ E_1(r) \otimes \text{id}_{E_2(\bar{X}')}], \end{aligned}$$

which is in the ideal $I(E_1, E_2)$ defined in Proposition 398. Thus, while $[X, s]^*$ depends on the chosen conjugate (\bar{X}, r, \bar{r}) of X , its image $\gamma([X, s]^*) \in A(E_1, E_2)$ doesn't.

In order to be able to define a $*$ -operation on $A(E_1, E_2)$ by $x^* := \gamma \circ \star \circ \gamma^{-1}(x)$ we must show that the composite map $\gamma \circ \star : A_0(E_1, E_2) \rightarrow A(E_1, E_2)$ maps $I(E_1, E_2)$ to zero. To this purpose, let $X, Y \in \mathcal{C}, s : X \rightarrow Y, a \in \text{Hom}(E_2(Y), E_1(X))$ and choose conjugates $(\bar{X}, r_X, \bar{r}_X), (\bar{Y}, r_Y, \bar{r}_Y)$. Then

$$\begin{aligned} & [X, a \circ E_2(s)]^* - [Y, E_1(s) \circ a]^* \\ & = [\bar{X}, \text{id}_{E_1(\bar{X})} \otimes E_2(\bar{r}_X^*) \circ \text{id}_{E_1(\bar{X})} \otimes (a \circ E_2(s))^* \otimes \text{id}_{E_2(\bar{X})} \circ E_1(r_X) \otimes \text{id}_{E_2(\bar{X})}] \\ & - [\bar{Y}, \text{id}_{E_1(\bar{Y})} \otimes E_2(\bar{r}_Y^*) \circ \text{id}_{E_1(\bar{Y})} \otimes (E_1(s) \circ a)^* \otimes \text{id}_{E_2(\bar{Y})} \circ E_1(r_Y) \otimes \text{id}_{E_2(\bar{Y})}] \\ & = [\bar{X}, \tilde{a} \circ E_2(\tilde{s})] - [\bar{Y}, E_1(\tilde{s}) \circ \tilde{a}], \end{aligned}$$

with $\tilde{a} \in \text{Hom}_{\mathcal{H}}(E_2(\bar{Y}), E_1(\bar{X}))$ and $\tilde{s} \in \text{Hom}(\bar{X}, \bar{Y})$ defined by

$$\begin{aligned} \tilde{a} &= \text{id}_{E_1(\bar{X})} \otimes E_2(\bar{r}_X^*) \circ \text{id}_{E_1(\bar{X})} \otimes a^* \otimes \text{id}_{E_2(\bar{Y})} \circ E_1(r_X) \otimes \text{id}_{E_2(\bar{Y})}, \\ \tilde{s} &= \text{id}_{\bar{Y}} \otimes \bar{r}_X^* \circ \text{id}_{\bar{Y}} \otimes s^* \otimes \text{id}_{\bar{X}} \circ r_Y \otimes \text{id}_{\bar{X}}. \end{aligned}$$

This clearly is in $I(E_1, E_2)$, thus $x^* := \gamma \circ \star \circ \gamma^{-1}(x)$ defines a $*$ -operation on $A(E_1, E_2)$.

Now it is obvious that the resulting map $*$ on $A(E_1, E_2)$ is additive and antilinear. It also is involutive and antimultiplicative as one verifies by an appropriate use of the conjugate equations. We omit the tedious but straightforward computations. It remains to show positivity of the $*$ -operation. Consider $[X, s] \in A_0(E_1, E_2)$, pick a conjugate (\bar{X}, r, \bar{r}) and compute $[X, s]^* \cdot [X, s] = [\bar{X} \otimes X, t]$, where t equals

$$d_{\bar{X}, X}^1 \circ \left(\text{id}_{E_1(\bar{X})} \otimes E_2(\bar{r}^*) \circ \text{id}_{E_1(\bar{X})} \otimes s^* \otimes \text{id}_{E_2(\bar{X})} \circ E_1(r) \otimes \text{id}_{E_2(\bar{X})} \right) \circ s \circ (d_{\bar{X}, X}^2)^*.$$

Now,

$$\begin{aligned}
 [\overline{X} \otimes X, t] &= [\overline{X} \otimes X, E_1(r^*) \circ E_1(r) \circ t] = [\mathbf{1}, E_1(r) \circ t \circ E_2(r^*)] \\
 &= \left[\mathbf{1}, E_1(r^*) \circ \left(\text{id}_{E_1(\overline{X})} \otimes E_2(r^*) \circ \text{id}_{E_1(\overline{X})} \otimes s^* \otimes \text{id}_{E_2(\overline{X})} \right. \right. \\
 &\quad \left. \left. \circ E_1(r) \otimes \text{id}_{E_2(\overline{X})} \right) \otimes s \circ E_2(r) \right] \\
 &= [\mathbf{1}, E_1(r^*) \circ \text{id} \otimes (s \circ s^*) \circ E_1(r)] = [\mathbf{1}, u^*u],
 \end{aligned}$$

where we have used the conjugate equations and put $u = \text{id} \otimes s^* \circ E_1(r)$. Thus, $[X, s]^* \cdot [X, s] = [\mathbf{1}, u^*u]$ is zero iff u^*u is zero. By positivity of the $*$ -operation in \mathcal{H} , this holds iff $u = 0$. Using once again the conjugate equations we see that this is equivalent to $s = 0$. Thus for elements $a \in A(E_1, E_2)$ of the form $[X, s]$, the implication $a^*a = 0 \Rightarrow a = 0$ holds. For a general $a = \sum_i [X_i, s_i]$ we pick isometries $v_i : X_i \rightarrow X$ such that $\sum_i v_i \circ v_i^* = \text{id}_X$ (i.e. $X \cong \oplus_i X_i$). Then $[X_i, s_i] = [X, E_1(v_i) \circ s_i \circ E_2(v_i^*)]$, thus

$$\sum_i [X_i, s_i] = [X, \sum_i E_1(v_i) \circ s_i \circ E_2(v_i^*)],$$

implying that every element of $A(E_1, E_2)$ can be written as $[X, s]$, and we are done. ■

PROPOSITION 394. *Let \mathcal{C} be a TC^* and let $E_1, E_2 : \mathcal{C} \rightarrow \mathcal{H}$ be $*$ -preserving fiber functors. Then*

$$\|a\| = \inf_b \sup_{X \in \mathcal{C}} \|b_X\|_{\text{End}E(X)},$$

where the infimum is over all representers $b \in A_0(E_1, E_2)$ of $a \in A(E_1, E_2)$, defines a C^* -norm on $A(E_1, E_2)$.

Proof. Let $[X, s], [Y, t] \in A_0(E_1, E_2)$. Then $[X, s] \cdot [Y, t] = [X \otimes Y, u]$, where $u = d_{X,Y}^1 \circ s \otimes t \circ (d_{X,Y}^2)^{-1}$. Since $d_{X,Y}^1, d_{X,Y}^2$ are unitaries, we have $\|[X \otimes Y, u]\| = \|u\| \leq \|s\| \cdot \|t\|$. Thus $\|b\| = \sup_{X \in \mathcal{C}} \|b_X\|_{\text{End}E(X)}$ defines a submultiplicative norm on $A_0(E_1, E)$, and the above formula for $\|a\|$ is the usual definition of a norm on the quotient algebra $A_0(E_1, E_2)/I(E_1, E_2)$. This norm satisfies $\|[X, s]\| = \|s\|$. Since every $a \in A(E_1, E_2)$ can be written as $[X, s]$, we have $\|a\| = 0 \Rightarrow a = 0$. Finally, the computations in the proof of Proposition 393 imply

$$\|[X, s]^* [X, s]\| = \|[\mathbf{1}, u^*u]\| = \|u^*u\| = \|u\|^2 = \|s\|^2 = \|[X, s]\|^2,$$

which is the C^* -condition. ■

DEFINITION 395. Let \mathcal{C} be a TC^* and let $E_1, E_2 : \mathcal{C} \rightarrow \mathcal{H}$ be $*$ -preserving fiber functors. Then $\mathcal{A}(E_1, E_2)$ denotes the $\|\cdot\|$ -completion of $A(E_1, E_2)$. (This is a unital C^* -algebra, which is commutative if \mathcal{C}, E_1, E_2 are symmetric.)

B.4 Uniqueness of fiber functors

LEMMA 396. [Joyal and Street, 1993a] Let \mathcal{C} be a TC^* , \mathcal{D} a strict tensor category and $E_1, E_2 : \mathcal{C} \rightarrow \mathcal{D}$ strict tensor functors. Then any monoidal natural transformation $\alpha : E_1 \rightarrow E_2$ is a natural isomorphism.

Proof. It is sufficient to show that every component $\alpha_X : E_1(X) \rightarrow E_2(X)$ has a two-sided inverse $\beta_X : E_2(X) \rightarrow E_1(X)$. The family $\{\beta_X, X \in \mathcal{C}\}$ will then automatically be a natural transformation. If (\bar{X}, r, \bar{r}) is a conjugate for X , monoidality of α implies

$$(58) \quad E_2(r^*) \circ \alpha_{\bar{X}} \otimes \alpha_X = E_2(r^*) \circ \alpha_{\bar{X} \otimes X} = \alpha_{\mathbf{1}} \circ E_1(r^*) = E_1(r^*).$$

If we now define

$$\beta_X = \text{id}_{E_1(X)} \otimes E_2(r^*) \circ \text{id}_{E_1(X)} \otimes \alpha_{\bar{X}} \otimes \text{id}_{E_2(X)} \circ E_1(\bar{r}) \otimes \text{id}_{E_2(X)},$$

we have

$$\begin{aligned} \beta_X \circ \alpha_X &= (\text{id}_{E_1(X)} \otimes E_2(r^*) \circ \text{id}_{E_1(X)} \otimes \alpha_{\bar{X}} \otimes \text{id}_{E_2(X)} \circ E_1(\bar{r}) \otimes \text{id}_{E_2(X)}) \circ \alpha_X \\ &= \text{id}_{E_1(X)} \otimes E_2(r^*) \circ \text{id}_{E_1(X)} \otimes \alpha_{\bar{X}} \otimes \alpha_X \circ E_1(\bar{r}) \otimes \text{id}_{E_1(X)} \\ &= \text{id}_{E_1(X)} \otimes E_1(r^*) \circ E_1(\bar{r}) \otimes \text{id}_{E_1(X)} = \text{id}_{E_1(X)}. \end{aligned}$$

The argument for $\alpha_X \circ \beta_X = \text{id}_{E_2(X)}$ is similar. ■

REMARK 397. The lemma remains correct if one allows E_1, E_2 (or even \mathcal{C}, \mathcal{D}) to be non-strict. To adapt the proof one must replace $E_1(r)$ (which is a morphism $E_1(\mathbf{1}) \rightarrow E_1(\bar{X} \otimes X)$) by $(d_{\bar{X}, X}^{E_1})^{-1} \circ E_1(r) \circ e^{E_1}$ (which is a morphism $\mathbf{1}_{\text{Vect}} \rightarrow E_1(\bar{X}) \otimes E_1(X)$). Similarly with $E_2(\bar{r})$.

PROPOSITION 398. Let \mathcal{C} be a TC^* and $E_1, E_2 : \mathcal{C} \rightarrow \text{Vect}_{\mathbb{C}}$ fiber functors. The pairing between $A_0(E_1, E_2)$ and the vector space

$$\begin{aligned} \text{Nat}(E_1, E_2) &= \left\{ (\alpha_X)_{X \in \mathcal{C}} \in \prod_{X \in \mathcal{C}} \text{Hom}(E_1(X), E_2(X)) \mid \right. \\ &\quad \left. E_2(s) \circ \alpha_X = \alpha_Y \circ E_1(s) \ \forall s : X \rightarrow Y \right\} \end{aligned}$$

of natural transformations $E_1 \rightarrow E_2$ that is given, for $(\alpha_X) \in \text{Nat}(E_1, E_2)$ and $a \in A_0(E_1, E_2)$, by

$$(59) \quad \langle \alpha, a \rangle = \sum_{X \in \mathcal{C}} \text{Tr}_{E_1(X)}(a_X \alpha_X)$$

descends to a pairing between $\text{Nat}(E_1, E_2)$ and the quotient algebra $A(E_1, E_2) = A_0(E_1, E_2)/I(E_1, E_2)$ such that

$$\text{Nat}(E_1, E_2) \cong A(E_1, E_2)^*.$$

Under this isomorphism, an element $a \in A(E_1, E_2)^*$ corresponds to an element of $\text{Nat}_{\otimes}(E_1, E_2)$, i.e. a monoidal natural transformation (thus isomorphism by Lemma 396), iff it is a character, to wit multiplicative.

Proof. The dual vector space of the direct sum $A_0(E_1, E_2)$ is the direct product $\prod_{X \in \mathcal{C}} \text{Hom}(E_2(X), E_1(X))^*$, and since the pairing between $\text{Hom}(E_2(X), E_1(X)) \times \text{Hom}(E_1(X), E_2(X))$, $s \times t \mapsto \text{Tr}(s \circ t)$ is non-degenerate, we have

$$A_0(E_1, E_2)^* \cong \prod_{X \in \mathcal{C}} \text{Hom}(E_1(X), E_2(X))$$

w.r.t. the pairing given in (59). Now, $A(E_1, E_2)$ is the quotient of $A_0(E_1, E_2)$ by the subspace $I(E_1, E_2)$, thus the dual space $A(E_1, E_2)^*$ consists precisely of those elements of $A_0(E_1, E_2)^*$ that are identically zero on $I(E_1, E_2)$. Assume $(\alpha_X)_{X \in \mathcal{C}}$ satisfies $\langle \alpha, a \rangle = 0$ for all $a \in I(E_1, E_2)$, equivalently $\langle \alpha, [X, a \circ E_2(s)] - [Y, E_1(s) \circ a] \rangle = 0$ for all $s : X \rightarrow Y$ and $a : E_2(Y) \rightarrow E_1(X)$. By definition (59) of the pairing, this is equivalent to

$$\text{Tr}_{E_1(X)}(a \circ E_2(s) \circ \alpha_X) - \text{Tr}_{E_1(Y)}(E_1(s) \circ a \circ \alpha_Y) = 0$$

for all $s : X \rightarrow Y$ and $a \in \text{Hom}(E_2(Y), E_1(X))$. Non-degeneracy of the trace implies that $\alpha = (\alpha_X)_{X \in \mathcal{C}}$ must satisfy $E_2(s) \circ \alpha_X = \alpha_Y \circ E_1(s)$ for all $s : X \rightarrow Y$, thus $\alpha \in \text{Nat}(E_1, E_2)$, implying

$$A(E_1, E_2)^* \cong \text{Nat}(E_1, E_2).$$

Now we consider the question when the functional $\phi \in A(E_1, E_2)^*$ corresponding to $\alpha \in \text{Nat}(E_1, E_2)$ is a character, i.e. multiplicative. This is the case when

$$\langle \alpha, [X, s] \cdot [Y, t] \rangle = \langle \alpha, [X, s] \rangle \langle \alpha, [Y, t] \rangle \quad \forall [X, s], [Y, t] \in A(E_1, E_2).$$

(Strictly speaking, $[X, s], [Y, t]$ are representers in $A_0(E_1, E_2)$ for some elements in $A(E_1, E_2)$.) In view of (59) and the definition of the product in $A(E_1, E_2)$ this amounts to

$$\begin{aligned} \text{Tr}_{E_1(X \otimes Y)}(d_{X,Y}^1 \circ s \otimes t \circ (d_{X,Y}^2)^{-1} \circ \alpha_{X \otimes Y}) &= \text{Tr}_{E_1(X)}(s \circ \alpha_X) \text{Tr}_{E_1(Y)}(t \circ \alpha_Y) \\ &= \text{Tr}_{E_1(X) \otimes E_2(X)}((s \circ \alpha_X) \otimes (t \circ \alpha_Y)) \\ &= \text{Tr}_{E_1(X) \otimes E_2(X)}(s \otimes t \circ \alpha_X \otimes \alpha_Y). \end{aligned}$$

In view of the cyclic invariance and non-degeneracy of the trace, this is true for all $s : E_2(X) \rightarrow E_1(X)$ and $t : E_2(Y) \rightarrow E_1(Y)$, iff

$$\alpha_{X \otimes Y} = d_{X,Y}^2 \circ \alpha_X \otimes \alpha_Y \circ (d_{X,Y}^1)^{-1} \quad \forall X, Y \in \mathcal{C}.$$

This is precisely the condition for $\alpha \in \text{Nat}(E_1, E_2)$ to be monoidal, to wit $\alpha \in \text{Nat}_{\otimes}(E_1, E_2)$. ■

PROPOSITION 399. *Let \mathcal{C} be a TC^* and let $E_1, E_2 : \mathcal{C} \rightarrow \mathcal{H}$ be $*$ -preserving fiber functors. Then a monoidal natural transformation $\alpha \in \text{Nat}_{\otimes}(E_1, E_2)$ is unitary (i.e. each α_X is unitary) iff the corresponding character $\phi \in A(E_1, E_2)$ is a $*$ -homomorphism (i.e. $\phi(a^*) = \overline{\phi(a)}$).*

Proof. Let $\alpha \in \text{Nat}_{\otimes}(E_1, E_2)$ and $[X, s] \in A(E_1, E_2)$. By definition of the pairing of $A(E_1, E_2)$ and $\text{Nat}(E_1, E_2)$,

$$\phi([X, s]) = \langle \alpha, [X, s] \rangle = \text{Tr}_{E_1(X)}(s \circ \alpha_X),$$

and therefore, using $\overline{\text{Tr}(AB)} = \text{Tr}(A^*B^*)$,

$$\overline{\phi([X, s])} = \text{Tr}_{E_1(X)}(s^* \circ \alpha_X^*).$$

On the other hand,

$$\begin{aligned} \phi([X, s]^*) &= \langle \alpha, [\overline{X}, \text{id}_{E_1(\overline{X})} \otimes E_2(\overline{r}^*) \circ \text{id}_{E_1(\overline{X})} \otimes s^* \otimes \text{id}_{E_2(\overline{X})} \circ E_1(r) \otimes \text{id}_{E_2(\overline{X})}] \rangle \\ &= \text{Tr}_{E_1(\overline{X})}(\text{id}_{E_1(\overline{X})} \otimes E_2(\overline{r}^*) \circ \text{id}_{E_1(\overline{X})} \otimes s^* \otimes \text{id}_{E_2(\overline{X})} \circ E_1(r) \otimes \text{id}_{E_2(\overline{X})} \circ \alpha_{\overline{X}}) \\ &= E_2(\overline{r}^*) \circ s^* \otimes \alpha_{\overline{X}} \circ E_1(\overline{r}) \\ &= E_2(\overline{r}^*) \circ (\alpha_X \circ \alpha_X^{-1} \circ s^*) \otimes \alpha_{\overline{X}} \circ E_1(\overline{r}) \\ &= E_1(\overline{r}^*) \circ (\alpha_X^{-1} \circ s^*) \otimes \text{id}_{E_2(\overline{X})} \circ E_1(\overline{r}) \\ &= \text{Tr}_{E_1(X)}(\alpha_X^{-1} \circ s^*). \end{aligned}$$

(In the fourth step we have used the invertibility of α (Lemma 396) and in the fifth equality we have used (58) with X and \overline{X} interchanged and r replaced by \overline{r} .) Now non-degeneracy of the trace implies that $\overline{\phi([X, s])} = \phi([X, s]^*)$ holds for all $[X, s] \in (E_1, E_2)$ iff $\alpha_X^* = \alpha_X^{-1}$ for all $X \in \mathcal{C}$, as claimed. ■

Now we are in a position to prove the first of our outstanding claims:

Proof of Theorem 373. By the preceding constructions, the $\|\cdot\|$ -closure $A(E_1, E_2)$ of $A(E_1, E_2)$ is a commutative unital C^* -algebra. As such it has (lots of) characters, i.e. unital $*$ -homomorphisms into \mathbb{C} . (Cf. e.g. Theorem 401 below.) Such a character restricts to $A(E_1, E_2)$ and corresponds, by Propositions 398 and 399, to a unitary monoidal natural transformation $\alpha \in \text{Nat}(E_1, E_2)$. ■

REMARK 400. 1. The discussion of the algebra $A(E_1, E_2)$ is inspired by the one in the preprint [Bichon, ND] that didn't make it into the published version [Bichon, 1998]. The above proof of Theorem 373 first appeared in [Bichon, 1999].

2. Lemma 396 implies that the category consisting of fiber functors and monoidal natural transformations is a groupoid, i.e. every morphism is invertible. Theorem 373 then means that the category consisting of symmetric $*$ -preserving fiber functors and unitary monoidal natural transformations is a transitive groupoid, i.e. all objects are isomorphic. That this groupoid is non-trivial is the statement of Theorem 382, whose proof will occupy the bulk of this section, beginning in Subsection B.6.

B.5 The concrete Tannaka theorem. Part II

In order to prove Proposition 375 we need the formalism of the preceding subsections. We write $\mathcal{A}(E)$ for the commutative unital C^* -algebra $\mathcal{A}(E, E)$ defined

earlier. In order to study this algebra we need some results concerning commutative unital C^* -algebras that can be gathered, e.g., from [Pedersen, 1989].

THEOREM 401. *Let \mathcal{A} be a commutative unital C^* -algebra. Let \mathcal{A}^* be its Banach space dual and let*

$$\begin{aligned} P(\mathcal{A}) &= \{\phi \in \mathcal{A}^* \mid \phi(1) = 1, \|\phi\| \leq 1\}, \\ X(\mathcal{A}) &= \{\phi \in \mathcal{A}^* \mid \phi(1) = 1, \phi(ab) = \phi(a)\phi(b), \phi(a^*) = \overline{\phi(a)} \ \forall a, b \in \mathcal{A}\}. \end{aligned}$$

$P(\mathcal{A})$ and $X(\mathcal{A})$ are equipped with the w^ -topology on \mathcal{A} according to which $\phi_\iota \rightarrow \phi$ iff $\phi_\iota(a) \rightarrow \phi(a)$ for all $a \in \mathcal{A}$. Then:*

- (i) $X(\mathcal{A}) \subset P(\mathcal{A})$. (I.e., $*$ -characters have norm ≤ 1 .)
- (ii) $X(\mathcal{A})$ is compact w.r.t. the w^* -topology on $P(\mathcal{A})$.
- (iii) The map $\mathcal{A} \rightarrow C(X(\mathcal{A}))$ given by $a \mapsto (\phi \mapsto \phi(a))$ is an isomorphism of C^* -algebras.
- (iv) The convex hull

$$\left\{ \sum_{i=1}^N c_i \phi_i, \ N \in \mathbb{N}, \ c_i \in \mathbb{R}_+, \ \sum_i c_i = 1, \ \phi_i \in X(\mathcal{A}) \right\}$$

of $X(\mathcal{A})$ is w^ -dense in $P(\mathcal{A})$.*

Proof. (i) Any unital $*$ -homomorphism α of Banach algebras satisfies $\|\alpha(a)\| \leq \|a\|$.

(ii) By Alaoglu’s theorem [Pedersen, 1989, Theorem 2.5.2], the unit ball of \mathcal{A}^* is compact w.r.t. the w^* -topology, and so are the closed subsets $X(\mathcal{A}) \subset P(\mathcal{A}) \subset \mathcal{A}^*$.

(iii) This is Gelfand’s theorem, cf. [Pedersen, 1989, Theorem 4.3.13].

(iv) This is the Krein-Milman theorem, cf. Theorem 2.5.4 together with Proposition 2.5.7 in [Pedersen, 1989]. ■

Theorem 401, (ii) implies that the set $X \equiv X(\mathcal{A}(E))$ of $*$ -characters of $\mathcal{A}(E)$ is a compact Hausdorff space w.r.t. the w^* -topology. By (iii) and Proposition 399, the elements of X are in bijective correspondence with the set G_E of unitary monoidal transformations of the functor E .

LEMMA 402. *The bijection $X \cong G_E$ is a homeomorphism w.r.t. the topologies defined above.*

Proof. By definition of the product topology on $\prod_{X \in \mathcal{C}} \mathcal{U}(E(X))$, a net (g_ι) in G_E converges iff the net $(g_{\iota, X})$ in $\mathcal{U}(E(X))$ converges for every $X \in \mathcal{C}$. On the other hand, a net (ϕ_ι) in X converges iff $(\phi_\iota(a))$ converges in \mathbb{C} for every $a \in \mathcal{A}(E)$. In view of the form of the correspondence $\phi \leftrightarrow g$ established in Proposition 398, these two notions of convergence coincide. ■

The homeomorphism $X \cong G_E$ allows to transfer the topological group structure that G_E automatically has to the compact space X . Now we are in a position to complete the proof of our second outstanding claim.

Proof of Proposition 375. Since \mathcal{C} is semisimple and essentially small, there exist a set I and a family $\{X_i, i \in I\}$ of irreducible objects such that every object is (isomorphic to) a finite direct sum of objects from this set. If $\text{Nat}(E) \equiv \text{Nat}(E, E)$ is the space of natural transformations from E to itself, with every $\alpha \in \text{Nat}(E)$ we can associate the family $(\alpha_i = \alpha_{X_i})_{i \in I}$, which is an element of $\prod_{i \in I} \text{End } E(X_i)$. Semisimplicity of \mathcal{C} and naturality of α imply that every such element arises from exactly one natural transformation of E . (In case it is not obvious, a proof can be found in [Müger *et al.*, 2004, Proposition 5.4].) In this way we obtain an isomorphism

$$\gamma : \text{Nat}(E) \rightarrow \prod_{i \in I} \text{End } E(X_i), \quad \alpha \mapsto (\alpha_{X_i})_{i \in I}$$

of vector spaces. Now consider the linear map

$$\delta : \bigoplus_{i \in I} \text{End } E(X_i) \rightarrow A(E), \quad (a_i) \mapsto \sum_i [X_i, a_i].$$

Since every $a \in A(E)$ can be written as $[X, s]$ (proof of Proposition 393) and every $[X, s]$ is a sum of elements $[X_i, s_i]$ with X_i irreducible, δ is surjective. When understood as a map to $A_0(E)$, δ obviously is injective. As a consequence of $\text{Hom}(X_i, X_j) = \{0\}$ for $i \neq j$, the image in $A_0(E)$ of δ has trivial intersection with the ideal $I(E)$, which is the kernel of the quotient map $A_0(E) \rightarrow A(E)$, thus δ is injective and therefore an isomorphism (of vector spaces, not algebras). If the C^* -norm on $A(E)$ is pulled back via δ we obtain the norm

$$\|(a_i)_{i \in I}\| = \sup_{i \in I} \|a_i\|_{\text{End } E(X_i)}$$

on $\bigoplus_{i \in I} \text{End } E(X_i)$. Thus we have an isomorphism $\bar{\delta} : \overline{\bigoplus_{i \in I} \text{End } E(X_i)}^{\|\cdot\|} \rightarrow \mathcal{A}(E)$ of the norm closures. W.r.t. the isomorphisms γ, δ , the pairing $\langle \cdot, \cdot \rangle : \text{Nat}(E) \times A(E) \rightarrow \mathbb{C}$ of Proposition 398 becomes

$$\langle \cdot, \cdot \rangle^\sim : \prod_{i \in I} \text{End } E(X_i) \times \bigoplus_{i \in I} \text{End } E(X_i) \rightarrow \mathbb{C}, \quad (\alpha_{X_i}) \times (a_i) \mapsto \sum_{i \in I} \text{Tr}_{E(X_i)}(\alpha_i a_i).$$

(More precisely: $\langle \cdot, \delta(\cdot) \rangle = \langle \gamma(\cdot), \cdot \rangle^\sim$ as maps $\text{Nat}(E) \times \bigoplus_{i \in I} \text{End } E(X_i) \rightarrow \mathbb{C}$.) Thus if $\alpha \in \text{Nat}(E)$ is such that $\gamma(\alpha) \in \prod_{i \in I} \text{End } E(X_i)$ has only finitely many non-zero components (i.e. $\gamma(\alpha) \in \bigoplus_{i \in I} \text{End } E(X_i)$), then $\langle \alpha, \cdot \rangle \in A(E)^*$ extends to an element of $\mathcal{A}(E)^*$.

Now (iv) of Theorem 401 implies that every $\phi \in \mathcal{A}(E)^*$ is the w^* -limit of a net (ϕ_ι) in the \mathbb{C} -span of the $*$ -characters $X(\mathcal{A}(E))$ of $A(E)$. Thus for every $(\alpha_i) \in \bigoplus_{i \in I} \text{End } E(X_i)$ there is a such a net (ϕ_ι) for which

$$w^* - \lim \phi_\iota = \langle \gamma^{-1}((\alpha_i)), \cdot \rangle \in \mathcal{A}(E)^*.$$

Restricting the ϕ_i to $A(E)$ and using the isomorphism $\text{Nat } E \cong A(E)^*$, we obtain a net in $\text{Nat } E$ that converges to $\gamma^{-1}((\alpha_i))$. By Propositions 398, 399, the isomorphism $A(E)^* \rightarrow \text{Nat } E$ maps the elements of $X(\mathcal{A}(E))$ to the unitary natural monoidal transformations of E , i.e. to elements of G_E . Thus, in particular for every finite $S \subset I$ we have

$$\overline{\text{span}}_{\mathbb{C}} \left\{ \underbrace{\pi_{s_1}(g) \oplus \cdots \oplus \pi_{s_{|S|}}(g)}_{\text{all } s \in S}, g \in G_E \right\} = \bigoplus_{s \in S} \text{End } E(X_s),$$

which clearly is a good deal more than claimed in Proposition 375. ■

This concludes the proof of all ingredients that went into the proof of Theorem 377. From the proof it is obvious that the commutative C^* -algebra $\mathcal{A}(E)$ is just the algebra of continuous functions on the compact group G_E , whereas $A(E)$ is the linear span of the matrix elements of the finite dimensional representations of G_E .

B.6 Making a symmetric fiber functor $*$ -preserving

The aim of his subsection is to prove the following result, which seems to be new:

THEOREM 403. *An even STC^* \mathcal{C} that admits a symmetric fiber functor $\mathcal{C} \rightarrow \text{Vect}_{\mathbb{C}}$ also admits a symmetric $*$ -preserving fiber functor $\mathcal{C} \rightarrow \mathcal{H}$.*

LEMMA 404. *Let \mathcal{C} be an STC^* and $E : \mathcal{C} \rightarrow \text{Vect}_{\mathbb{C}}$ a symmetric fiber functor. Choose arbitrary positive definite inner products $\langle \cdot, \cdot \rangle_X^0$ (i.e. Hilbert space structures) on all of the spaces $E(X), X \in \mathcal{C}$. Then the maps $X \mapsto E(X)$ and $s \mapsto E(s^*)^\dagger$, where $E(s^*)^\dagger$ is the adjoint of $E(s^*)$ w.r.t. the inner products $\langle \cdot, \cdot \rangle_X^0$, define a faithful functor $\tilde{E} : \mathbb{C} \rightarrow \text{Vect}_{\mathbb{C}}$. With $d_{X,Y}^{\tilde{E}} = ((d_{X,Y}^E)^\dagger)^{-1}$ and $e^{\tilde{E}} = ((e^E)^\dagger)^{-1}$, this is a symmetric fiber functor.*

Proof. First note that $s \mapsto \tilde{E}(s)$ is \mathbb{C} -linear and really defines a functor, since $\tilde{E}(\text{id}_X) = \text{id}_{\tilde{E}(X)}$ and

$$\tilde{E}(sot) = E((sot)^*)^\dagger = E(t^* \circ s^*)^\dagger = (E(t^*) \circ E(s^*))^\dagger = E(s^*)^\dagger \circ E(t^*)^\dagger = \tilde{E}(s) \circ \tilde{E}(t).$$

Faithfulness of E clearly implies faithfulness of \tilde{E} . With $d_{X,Y}^{\tilde{E}} = ((d_{X,Y}^E)^\dagger)^{-1}$ and $e^{\tilde{E}} = ((e^E)^\dagger)^{-1}$, commutativity of the diagrams (56) and (57) is obvious. Since E is a tensor functor, we have

$$E(s \otimes t) \circ d_{X,Y}^E = d_{X',Y'}^E \circ E(s) \otimes E(t)$$

for all $s : X \rightarrow X', t : Y \rightarrow Y'$, which is equivalent to

$$(E(s \otimes t))^\dagger \circ ((d_{X',Y'}^E)^{-1})^\dagger = ((d_{X,Y}^E)^{-1})^\dagger \circ (E(s) \otimes E(t))^\dagger.$$

Since this holds for all s, t , we have proven naturality of the family $(d_{X,Y}^{\tilde{E}})$, thus \tilde{E} is a tensor functor. The computation

$$\tilde{E}(c_{X,Y}) = E(c_{X,Y}^*)^\dagger = E(c_{Y,X})^\dagger = \Sigma_{E(Y),E(X)}^\dagger = \Sigma_{E(X),E(Y)},$$

where we have used $\Sigma_{H,H'}^\dagger = \Sigma_{H',H}$, shows that \tilde{E} is also symmetric. Thus \tilde{E} is a symmetric fiber functor. ■

Now the discussion of Subsection B.3 applies and provides us with a commutative unital \mathbb{C} -algebra $A(E, \tilde{E})$. However, we cannot appeal to Proposition 393 to conclude that $A(E, \tilde{E})$ is a $*$ -algebra, since E, \tilde{E} are not $*$ -preserving. In fact, for arbitrary symmetric fiber functors E_1, E_2 there is no reason for the existence of a positive $*$ -operation on $A(E_1, E_2)$, but in the present case, where the two functors are related by $E_2(s) = E_1(s^*)^\dagger$, this is true:

PROPOSITION 405. *Let \mathcal{C} be an STC^* , $E : \mathcal{C} \rightarrow \text{Vect}_{\mathbb{C}}$ a symmetric fiber functor and \tilde{E} as defined above. Then*

$$[X, s]^\star = [X, s^\dagger]$$

is well defined and is a positive $*$ -operation on $A(E, \tilde{E})$. With respect to this $*$ -operation, the norm $\| \cdot \|$ from Proposition 394 is a C^* -norm, i.e. $\|a^\star a\| = \|a\|^2$ for all $a \in A(E, \tilde{E})$.

Proof. For $[X, s] \in A_0(E, \tilde{E})$ we define $[X, s]^\star = [X, s^\dagger]$, where s^\dagger is the adjoint of $s \in \text{End}E(X)$ w.r.t. the inner product on $E(X)$. Clearly, \star is involutive and antilinear. Now, if $s : X \rightarrow Y$, $a \in \text{Hom}(E_2(Y), E_1(X))$, then

$$\begin{aligned} ([X, a \circ E_2(s)] - [Y, E_1(s) \circ a])^\star &= [X, a \circ E(s^*)^\dagger]^\star - [Y, E(s) \circ a]^\star \\ &= [X, E(s^*) \circ a^\dagger] - [Y, a^\dagger \circ E(s)^\dagger] = [X, E_1(s^*) \circ a^\dagger] - [Y, a^\dagger \circ E_2(s^*)]. \end{aligned}$$

Since $s^* \in \text{Hom}(Y, X)$ and $a^\dagger \in \text{Hom}(E(X), E(Y))$, the right hand side of this expression is again in $I(E, \tilde{E})$. Thus $I(E, \tilde{E})$ is stable under \star , and \star descends to an antilinear involution on $A(E, \tilde{E})$. In $A_0(E, \tilde{E})$ we have

$$\begin{aligned} ([X, s] \cdot [Y, t])^\star &= [X \otimes Y, d_{X,Y}^{\tilde{E}} \circ s \otimes t \circ (d_{X,Y}^E)^{-1}]^\star \\ &= [X \otimes Y, (d_{X,Y}^E)^\dagger^{-1} \circ s \otimes t \circ (d_{X,Y}^E)^{-1}]^\star \\ &= [X \otimes Y, (d_{X,Y}^E)^\dagger^{-1} \circ s^\dagger \otimes t^\dagger \circ (d_{X,Y}^E)^{-1}] \\ &= [X \otimes Y, d_{X,Y}^{\tilde{E}} \circ s^\dagger \otimes t^\dagger \circ (d_{X,Y}^E)^{-1}] \\ &= [X, s]^\star \cdot [Y, t]^\star. \end{aligned}$$

Together with commutativity of $A(E, \tilde{E})$ this implies that \star is antimultiplicative. Recall that there is an isomorphism $\delta : \bigoplus_{i \in I} \text{End} E(X_i) \rightarrow A(E, \tilde{E})$ such that $\|\delta((a_i)_{i \in I})\| = \sup_i \|a_i\|$, where $\| \cdot \|$ is the norm defined in Subsection B.3. By definition of \star we have $\delta((a_i)^\star) = \delta((a_i^\dagger))$, implying $\|a^\star a\| = \|a\|^2$. Thus $(A(E, \tilde{E}), \star, \| \cdot \|)$ is a pre- C^* -algebra. ■

(Note that the involution \star has nothing at all to do with the one defined in Subsection B.3!)

PROPOSITION 406. *Let \mathcal{C} be an STC^* and $E : \mathcal{C} \rightarrow \text{Vect}_{\mathbb{C}}$ a symmetric fiber functor. With \tilde{E} as defined above, there exists a natural monoidal isomorphism $\alpha : E \rightarrow \tilde{E}$, whose components α_X are positive, i.e. $\langle u, \alpha_X u \rangle_X^0 > 0$ for all nonzero $u \in E(X)$.*

Proof. As in Subsection B.4, the norm-completion $\mathcal{A}(E, \tilde{E})$ of $A(E, \tilde{E})$ is a commutative unital C^* -algebra and therefore admits a $*$ -character $\phi : \mathcal{A}(E, \tilde{E}) \rightarrow \mathbb{C}$. Restricting to $A(E, \tilde{E})$, Proposition 398 provides a monoidal natural isomorphism $\alpha : E \rightarrow \tilde{E}$. But we know more: The character ϕ is positive, i.e. $\phi(a^*a) > 0$ for all $a \neq 0$. With $a = [X, s]$ and taking (59) into account, we have

$$\begin{aligned} \phi(a^*a) &= \phi([X, s^\dagger s]) = \text{Tr}_{E(X)}(s^\dagger s \alpha_X) = \text{Tr}_{E(X)}(s \alpha_X s^\dagger) \\ &= \sum_i \langle e_i, s \alpha_X s^\dagger e_i \rangle_X^0 = \sum_i \langle s^\dagger e_i, \alpha_X s^\dagger e_i \rangle_X^0, \end{aligned}$$

where $\{e_i\}$ is any basis of $E(X)$ that is orthonormal w.r.t. $\langle \cdot, \cdot \rangle_X^0$. This is positive for all $a = [X, s] \in \mathcal{A}(E, \tilde{E})$ iff $\langle u, \alpha_X u \rangle_X^0 > 0$ for all nonzero $u \in E(X)$. ■

Now we are in a position to prove the main result of this subsection, which is a more specific version of Theorem 403.

THEOREM 407. *Let \mathcal{C} be an even STC^* and $E : \mathcal{C} \rightarrow \text{Vect}_{\mathbb{C}}$ a symmetric fiber functor. Then there exist Hilbert space structures (i.e. positive definite inner products $\langle \cdot, \cdot \rangle_X$) on the spaces $E(X), X \in \mathcal{C}$ such that $X \mapsto (E(X), \langle \cdot, \cdot \rangle_X)$ is a $*$ -preserving symmetric fiber functor $\mathcal{C} \rightarrow \mathcal{H}$.*

Proof. Pick non-degenerate inner products $\langle \cdot, \cdot \rangle_X^0$ on the spaces $E(X), X \in \mathcal{C}$. Since $E(\mathbf{1})$ is one-dimensional and spanned by $e^E \mathbf{1}$, where $1 \in \mathbb{C} = \mathbf{1}_{\text{Vect}_{\mathbb{C}}}$, we can define $\langle \cdot, \cdot \rangle_{\mathbf{1}}^0$ by $\langle ae^E \mathbf{1}, be^E \mathbf{1} \rangle_{\mathbf{1}}^0 = \bar{a}b$, as will be assumed in the sequel. Let \tilde{E} and $\alpha \in \text{Nat}_{\otimes}(E, \tilde{E})$ as above. Defining new inner products $\langle \cdot, \cdot \rangle_X$ on the spaces $E(X)$ by

$$\langle v, u \rangle_X = \langle v, \alpha_X u \rangle_X^0,$$

the naturality

$$\alpha_Y \circ E(s) = \tilde{E}(s) \circ \alpha_X = E(s^*)^\dagger \circ \alpha_X \quad \forall s : X \rightarrow Y$$

of (α_X) implies

$$\begin{aligned} \langle v, E(s)u \rangle_Y &= \langle v, \alpha_Y E(s)u \rangle_Y^0 = \langle v, E(s^*)^\dagger \alpha_X u \rangle_Y^0 \\ &= \langle E(s^*)v, \alpha_X u \rangle_X^0 = \langle E(s^*)v, u \rangle_X \end{aligned}$$

for all $s : X \rightarrow Y, u \in E(X), v \in E(Y)$. This is the same as $E(s^*) = E(s)^*$, where now $E(s)^*$ denotes the adjoint of $E(s)$ w.r.t. the inner products $\langle \cdot, \cdot \rangle$.

Thus the functor $X \mapsto (E(X), \langle \cdot, \cdot \rangle_X)$ is $*$ -preserving. The new inner products $\langle \cdot, \cdot \rangle_X$ are non-degenerate since the α_X are invertible, and the positivity property $\langle u, \alpha_X u \rangle_X^0 > 0$ for $u \neq 0$ implies that $(E(X), \langle \cdot, \cdot \rangle_X)$ is a Hilbert space. The monoidality

$$\alpha_{X \otimes Y} \circ d_{X,Y}^E = d_{X,Y}^{\tilde{E}} \circ \alpha_X \otimes \alpha_Y = ((d_{X,Y}^E)^\dagger)^{-1} \circ \alpha_X \otimes \alpha_Y \quad \forall X, Y$$

of the natural isomorphism $\alpha : E \rightarrow \tilde{E}$ is equivalent to

$$(60) \quad \alpha_X \otimes \alpha_Y = (d_{X,Y}^E)^\dagger \circ \alpha_{X \otimes Y} \circ d_{X,Y}^E.$$

Using this we have

$$\begin{aligned} \langle d_{X,Y}^E(u' \otimes v'), d_{X,Y}^E(u \otimes v) \rangle_{X \otimes Y} &= \langle d_{X,Y}^E(u' \otimes v'), \alpha_{X \otimes Y} \circ d_{X,Y}^E(u \otimes v) \rangle_{X \otimes Y}^0 \\ &= \langle (u' \otimes v'), (d_{X,Y}^E)^\dagger \circ \alpha_{X \otimes Y} \circ d_{X,Y}^E(u \otimes v) \rangle_{X \otimes Y}^0 \\ &= \langle (u' \otimes v'), (\alpha_X \otimes \alpha_Y)(u \otimes v) \rangle_{X \otimes Y}^0 \\ &= \langle u', \alpha_X u \rangle_X^0 \langle v', \alpha_Y v \rangle_Y^0 = \langle u', u \rangle_X \langle v', v \rangle_Y, \end{aligned}$$

thus the isomorphisms $d_{X,Y}^E : E(X) \otimes E(Y) \rightarrow E(X \otimes Y)$ are unitary w.r.t. the inner products $\langle \cdot, \cdot \rangle$.

Now, the compatibility (57) of d^E and e^E implies that $d_{1,1}^E \circ e^E 1 \otimes e^E 1 = e^E 1$ and therefore, using our choice of the inner product $\langle \cdot, \cdot \rangle_{\mathbf{1}}$,

$$\begin{aligned} \langle d_{1,1}^E(ae^E 1 \otimes be^E 1), d_{1,1}^E(ce^E 1 \otimes de^E 1) \rangle_{\mathbf{1} \otimes \mathbf{1}}^0 &= \langle abe^E 1, cde^E 1 \rangle_{\mathbf{1}}^0 \\ &= \overline{abcd} = \langle ae^E 1, ce^E 1 \rangle_{\mathbf{1}}^0 \langle be^E 1, de^E 1 \rangle_{\mathbf{1}}^0. \end{aligned}$$

This means that $d_{1,1}^E : E(\mathbf{1}) \otimes E(\mathbf{1}) \rightarrow E(\mathbf{1})$ is unitary w.r.t. the inner product $\langle \cdot, \cdot \rangle_{\mathbf{1}}^0$. Taking $X = Y = \mathbf{1}$ in (60) and using $\alpha_{\mathbf{1}} = \text{id}_{E(\mathbf{1})}$, we get $\lambda^2 = \lambda$. Since $\alpha_{\mathbf{1}}$ is invertible, we have $\lambda = 1$, thus $\alpha_{\mathbf{1}} = \text{id}_{E(\mathbf{1})}$ and therefore $\langle \cdot, \cdot \rangle_{\mathbf{1}} = \langle \cdot, \cdot \rangle_{\mathbf{1}}^0$. Now,

$$\langle e^E 1, e^E 1 \rangle_{\mathbf{1}} = \langle e^E 1, \alpha_{\mathbf{1}} e^E u \rangle_{\mathbf{1}}^0 = \langle e^E 1, e^E 1 \rangle_{\mathbf{1}}^0 = 1 = \langle 1, 1 \rangle_{\mathbb{C}},$$

thus $(e^E)^* e^E = \text{id}_{\mathbb{C}}$. By one-dimensionality of the spaces involved, we also have $e^E (e^E)^* = \text{id}_{E(\mathbf{1})}$, thus $e^E : \mathbf{1} \rightarrow E(\mathbf{1})$ is unitary w.r.t. the inner new products $\langle \cdot, \cdot \rangle$. ■

B.7 Reduction to finitely generated categories

DEFINITION 408. An additive tensor category \mathcal{C} is finitely generated if there exists an object $Z \in \mathcal{C}$ such that every object $X \in \mathcal{C}$ is a direct summand of some tensor power $Z^{\otimes n} = \underbrace{Z \otimes \cdots \otimes Z}_{n \text{ factors}}$, $n \in \mathbb{N}$, of Z .

LEMMA 409. Let \mathcal{C} be a TC^* . Then the finitely generated tensor subcategories of \mathcal{C} form a directed system, and \mathcal{C} is the inductive limit of the latter:

$$\mathcal{C} \cong \varinjlim_{i \in I} \mathcal{C}_i.$$

Proof. Consider all full tensor subcategories of \mathcal{C} . Since \mathcal{C} is essentially small, the equivalence classes of such subcategories form a set, partially ordered by inclusion. If $\mathcal{C}_1, \mathcal{C}_2 \subset \mathcal{C}$ are finitely generated, say by the objects X_1, X_2 , then the smallest tensor subcategory containing \mathcal{C}_1 and \mathcal{C}_2 is generated by $X_1 \oplus X_2$, thus we have a directed system. Clearly there is a full and faithful tensor functor $\lim_{\leftarrow i \in I} \mathcal{C}_i \rightarrow \mathcal{C}$. Since every object X is contained in a finitely generated tensor subcategory (e.g., the one generated by X), this functor is essentially surjective and thus an equivalence of categories, cf. [Mac Lane, 1998], in fact of tensor categories, cf. [Saavedra Rivano, 1972]. ■

REMARK 410. 1. The reason for considering finitely generated categories is that the existence problem of fiber functors for such categories can be approached using powerful purely algebraic methods. The general case can then be reduced to the finitely generated one using Lemma 409.

2. Note that we don't require the generator Z to be irreducible. Thus if we a priori only know that \mathcal{C} is generated by a finite set Z_1, \dots, Z_r of objects, the direct sum $Z = \oplus_i Z_i$ will be a (reducible) generator of \mathcal{C} . This is why only a single generating object appears in the definition.

3. If G is a compact group, the category $\text{Rep}_f G$ is finitely generated iff G is a Lie group. (Proof: \Leftarrow is a consequence of the well known representation theory of compact Lie groups. \Rightarrow : It is well known that the finite dimensional representations of G separate the elements of G . Therefore, if (H, π) is a generator of $\text{Rep}_f G$, it is clear that π must be faithful. Thus G is isomorphic to a closed subgroup of the compact Lie group $\mathcal{U}(H)$, and as such it is a Lie group.)

4. The index set I in Lemma 409 can be taken countable iff \mathcal{C} has countably many isomorphism classes of irreducible objects. The category $\text{Rep}_f G$, where G is a compact group, has this property iff G is second countable, equivalently metrizable.

In Subsections B.8-B.11 we will prove the following result, which we take for granted for the moment:

THEOREM 411. *A finitely generated even STC^* admits a symmetric fiber functor $E : \mathcal{C} \rightarrow \text{Vect}_{\mathbb{C}}$.*

Proof of Theorem 382. By Lemma 409, we can represent \mathcal{C} as an inductive limit $\lim_{\leftarrow i \in I} \mathcal{C}_i$ of finitely generated categories. Now Theorem 411 provides us with symmetric fiber functors $E_i : \mathcal{C}_i \rightarrow \text{Vect}_{\mathbb{C}}$, $i \in I$, and Theorem 407 turns the latter into $*$ -preserving symmetric fiber functors $E_i : \mathcal{C}_i \rightarrow \mathcal{H}$. By Theorem 377, we obtain compact groups $G_i = \text{Nat}_{\otimes} E_i$ (in fact compact Lie groups by Remark 410.3) with representations $\pi_{i,X}$ on the spaces $E_i(X)$, $X \in \mathcal{C}_i$ such that the functors $F_i : \mathcal{C}_i \rightarrow \text{Rep}_f G_i$, $X \mapsto (E_i(X), \pi_{i,X})$ are equivalences. Let now $i \leq j$, implying that \mathcal{C}_i is a full subcategory of \mathcal{C}_j . Then $E_j \upharpoonright \mathcal{C}_i$ is a fiber functor for \mathcal{C}_i and thus Theorem 373 implies the existence of a unitary natural isomorphism $\alpha^{i,j} : F_1 \rightarrow F_2 \upharpoonright \mathcal{C}_i$. (Note that $\alpha^{i,j}$ is not unique!) Now, by definition every $g \in G_2$ is a family

of unitaries $(g_X \in \mathcal{U}(E_2(X)))_{X \in \mathcal{C}_2}$ defining a monoidal natural automorphism of E_2 . Defining, for every $X \in \mathcal{C}_1$, $h_X := \alpha_X^{i,j} \circ g_X \circ (\alpha_X^{i,j})^*$ we see that the family $(h_X \in \mathcal{U}(E_1(X)))_{X \in \mathcal{C}_1}$ is a unitary monoidal natural automorphism of E_1 , to wit an element of G_1 . In this way we obtain a map $\beta^{i,j} : G_j \rightarrow G_i$ that clearly is a group homomorphism and continuous. By Schur's lemma, the unitary $\alpha_X^{i,j}$ is unique up to a phase for irreducible X . Thus for such X , $\beta_X^{i,j}$ is independent of the chosen $\alpha^{i,j}$, and thus $\beta^{i,j}$ is uniquely determined. It is also surjective in view of the Galois correspondence between the full tensor subcategories of $\text{Rep}_f G$ and the quotients G/N , where $N \subset G$ is a closed normal subgroup. Now the inverse limit

$$G = \lim_{\substack{\longleftarrow \\ i \in I}} G_i = \{(g_i \in G_i)_{i \in I} \mid \beta^{i,j}(g_j) = g_i \text{ whenever } i \leq j\}$$

is a compact group with obvious surjective homomorphisms $\gamma_i : G \rightarrow G_i$ for all $i \in I$. Now we define a functor $E : \mathcal{C} \rightarrow \text{Rep}_f G$ as follows: For every $X \in \mathcal{C}$ pick an $i \in I$ such that $X \in \mathcal{C}_i$ and define $F(X) = (E_i(X), \pi_i(X) \circ \gamma_i)$. Clearly this is an object in $\text{Rep}_f G$, and its isomorphism class is independent of the chosen $i \in I$. In this way we obtain a functor from $\mathcal{C} = \lim_{\longleftarrow} \mathcal{C}_i$ to $\text{Rep}_f G \cong \lim_{\longleftarrow} \text{Rep}_f G_i$ that restricts to equivalences $\mathcal{C}_i \rightarrow \text{Rep}_f G_i$. Thus E is full and faithful. Finally, E is essentially surjective since every finite dimensional representation of $G = \lim_{\longleftarrow} G_i$ factors through one of the groups G_i . ■

REMARK 412. In view of Remark 410.3, the preceding proof also shows that every compact group is an inverse limit of compact Lie groups.

B.8 Fiber functors from monoids

Our strategy to proving Theorem 411 will be essentially the one of Deligne [Deligne, 1990], replacing however the algebraic geometry in a symmetric abelian category by fairly elementary commutative categorical algebra. There are already several expositions of this proof [Bichon, 1998; Rosenberg, 2000; Háji, 2002], of which we find [Bichon, 1998] the most useful, see also [Bichon, ND]. However, we will give more details than any of these references, and we provide some further simplifications.

The following result clearly shows the relevance of the notions introduced in Subsection A.6 to our aim of proving Theorem 411:

PROPOSITION 413. *Let \mathcal{C} be a TC^* and $\widehat{\mathcal{C}}$ be a \mathbb{C} -linear strict tensor category containing \mathcal{C} as a full tensor subcategory. Let (Q, m, η) be a monoid in $\widehat{\mathcal{C}}$ satisfying*

- (i) $\dim \text{Hom}_{\widehat{\mathcal{C}}}(\mathbf{1}, Q) = 1$. (I.e., $\text{Hom}_{\widehat{\mathcal{C}}}(\mathbf{1}, Q) = \mathbb{C}\eta$.)
- (ii) For every $X \in \mathcal{C}$, there is $n(X) \in \mathbb{Z}_+$ such that $n(X) \neq 0$ whenever $X \not\cong 0$ and an isomorphism $\alpha_X : (Q \otimes X, m \otimes \text{id}_X) \rightarrow n(X) \cdot (Q, m)$ of Q -modules.

Then the functor $E : \mathcal{C} \rightarrow \text{Vect}_{\mathbb{C}}$ defined by

$$E : \mathcal{C} \rightarrow \mathcal{H}, \quad X \mapsto \text{Hom}_{\widehat{\mathcal{C}}}(\mathbf{1}, Q \otimes X),$$

together with

$$(61) \quad E(s)\phi = \text{id}_Q \otimes s \circ \phi, \quad s : X \rightarrow Y, \quad \phi \in \text{Hom}(\mathbf{1}, Q \otimes X)$$

is a faithful (strong) tensor functor and satisfies $\dim_{\mathbb{C}} E(X) = n(X)$.

If $\widehat{\mathcal{C}}$ has a symmetry c w.r.t. which (Q, m, η) is commutative then E is symmetric monoidal w.r.t. the symmetry Σ of $\text{Vect}_{\mathbb{C}}$, i.e. $E(c_{X,Y}) = \Sigma_{E(X),E(Y)}$.

Proof. We have $E(X) = \text{Hom}(\mathbf{1}, Q \otimes X) \cong \text{Hom}(\mathbf{1}, n(X)Q) \cong d(X)\text{Hom}(\mathbf{1}, Q) \cong \mathbb{C}^{n(X)}$, thus $E(X)$ is a vector space of dimension $n(X)$. Since $E(X) \neq 0$ for every non-zero $X \in \mathcal{C}$, the functor E is faithful.

To see that E is monoidal first observe that by (ii) we have $E(\mathbf{1}) = \text{Hom}(\mathbf{1}, Q) = \mathbb{C}\eta$. Thus there is a canonical isomorphism $e : \mathbb{C} = \mathbf{1}_{\text{Vect}_{\mathbb{C}}} \rightarrow E(\mathbf{1}) = \text{Hom}(\mathbf{1}, Q)$ defined by $c \mapsto c\eta$. Next we define morphisms

$$[d_{X,Y}^E : E(X) \otimes E(Y) \rightarrow E(X \otimes Y), \quad \phi \otimes \psi \mapsto m \otimes \text{id}_{X \otimes Y} \circ \text{id}_Q \otimes \phi \otimes \text{id}_Y \circ \psi.$$

By definition (61) of the map $E(s) : E(X) \rightarrow E(Y)$ it is obvious that the family $(d_{X,Y}^E)$ is natural w.r.t. both arguments. The equation

$$d_{X_1 \otimes X_2, X_3}^E \circ d_{X_1, X_2}^E \otimes \text{id}_{E(X_3)} = d_{X_1, X_2 \otimes X_3}^E \circ \text{id}_{E_1} \otimes d_{X_2, X_3}^E \quad \forall X_1, X_2, X_3 \in \mathcal{C}$$

required from a tensor functor is a straightforward consequence of the associativity of m . The verification is left as an exercise.

That $(E, (d_{X,Y}), e)$ satisfies the unit axioms is almost obvious. The first condition follows by

$$d_{X,\mathbf{1}}(\text{id}_{E(X)} \otimes e)\phi = d_{X,\mathbf{1}}(\phi \otimes \eta) = m \otimes \text{id}_X \circ \text{id}_Q \otimes \phi \circ \eta = \phi,$$

and the second is shown analogously.

So far, we have shown that E is a weak tensor functor for which $e : \mathbf{1}_{\mathcal{H}} \rightarrow E(\mathbf{1}_{\mathcal{C}})$ is an isomorphism. In order to conclude that E is a (strong) tensor functor it remains to show that the morphisms $d_{X,Y}^E$ are isomorphisms. Let $X, Y \in \mathcal{C}$. We consider the bilinear map

$$\begin{aligned} \gamma_{X,Y} : \quad & \text{Hom}_Q(Q, Q \otimes X) \boxtimes \text{Hom}_Q(Q, Q \otimes Y) \rightarrow \text{Hom}_Q(Q, Q \otimes X \otimes Y), \\ & s \boxtimes t \mapsto s \otimes \text{id}_Y \circ t. \end{aligned}$$

(We write \boxtimes rather than $\otimes_{\mathbb{C}}$ for the tensor product of $\text{Vect}_{\mathbb{C}}$ in order to avoid confusion with the tensor product in $Q - \text{Mod}$.) By 2., we have Q -module morphisms $s_i : Q \rightarrow Q \otimes X, s'_i : Q \otimes X \rightarrow Q$ for $i = 1, \dots, n(X)$ satisfying $s'_i \circ s_j = \delta_{ij}\text{id}_Q$, and $\sum_i s_i \circ s'_i = \text{id}_{Q \otimes X}$, and similar morphisms $t_i, t'_i, i = 1, \dots, n(Y)$ for X replaced by Y . Then the $\gamma_{ij} = \gamma_{X,Y}(s_i \otimes t_j)$ are linearly independent, since they satisfy $\gamma'_{i'j'} \circ \gamma_{ij} = \delta_{i'i}\delta_{j'j}\text{id}_Q$ with $\gamma'_{i'j'} = t'_{j'} \circ s'_{i'} \otimes \text{id}_Y$. Bijectivity of $\gamma_{X,Y}$ follows now

from the fact that both domain and codomain of $\gamma_{X,Y}$ have dimension $n(X)n(Y)$. Appealing to the isomorphisms $\delta_X : \text{Hom}_Q(Q, Q \otimes X) \mapsto \text{Hom}(\mathbf{1}, Q \otimes X)$ one easily shows

$$d_{X,Y}^E = \delta_{X \otimes Y} \circ \gamma_{X,Y} \circ \delta_X^{-1} \boxtimes \delta_Y^{-1},$$

which implies that $d_{X,Y}^E$ is an isomorphism for every $X, Y \in \mathcal{C}$.

We now assume that $\widehat{\mathcal{C}}$ has a symmetry c and that (Q, m, η) is commutative. In order to show that E is a symmetric tensor functor we must show that

$$E(c_{X,Y}) \circ d_{X,Y}^E = \Sigma_{E(X), E(Y)} \circ d_{Y,X}^E$$

for all $X, Y \in \mathcal{C}$. Let $\phi \in E(X), \psi \in E(Y)$.

By definition of E we have

$$(E(c_{X,Y}) \circ d_{X,Y}^E)(\phi \otimes \psi) = \text{id}_Q \otimes c_{X,Y} \circ m \otimes \text{id}_{X \otimes Y} \circ \text{id}_Q \otimes \phi \otimes \text{id}_Y \circ \psi$$

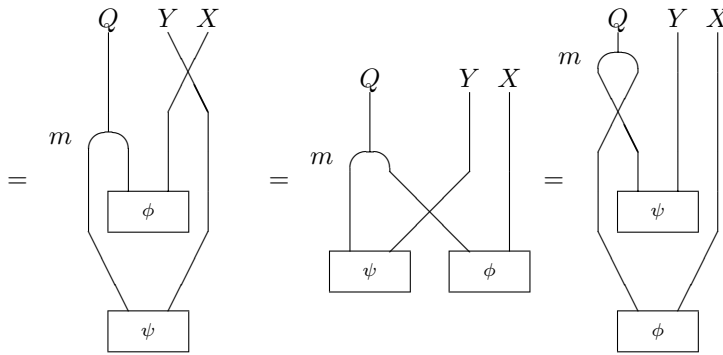

On the other hand,

$$(d_{Y,X}^E \circ c_{E(X), E(Y)})(\phi \otimes \psi) = (d_{Y,X}^E \circ \Sigma_{E(X), E(Y)})(\phi \otimes \psi) = d_{Y,X}^E(\psi \otimes \phi)$$

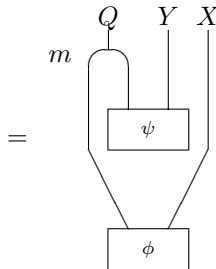

If m is commutative, i.e. $m = m \circ c_{Q,Q}$, these two expressions coincide, and we are done. ■

REMARK 414. 1. The property (ii) in the proposition is called the ‘absorbing property’.

2. The conditions in Proposition 413 are in fact necessary for the existence of a fiber functor! Assume that a tensor $*$ -category \mathcal{C} admits a $*$ -preserving fiber functor $E : \mathcal{C} \rightarrow \mathcal{H}$. By [Müger *et al.*, 2004], which reviews and extends work of Woronowicz, Yamagami and others, there is a discrete algebraic quantum group (A, Δ) such that $\mathcal{C} \simeq \text{Rep}_f(A, \Delta)$. In [Müger and Tuset, 2006] it is shown that taking $\widehat{\mathcal{C}} \simeq \text{Rep}(A, \Delta)$ (i.e. representations of any dimension) and $Q = \pi_l$, there is a monoid (Q, m, η) satisfying the conditions of Proposition 413. Namely, one can take $Q = \pi_l$, the left regular representation. In [Müger and Tuset, 2006] it is shown that (i) $\dim \text{Hom}(\pi_0, \pi_l) = 1$, i.e. there exists a non-zero morphism $\eta : \pi_0 \rightarrow \pi_l$, unique up to normalization; (ii) π_l has the required absorbing property; (iii) there exists a morphism $m : \pi_l \otimes \pi_l \rightarrow \pi_l$ such that $(Q = \pi_l, m, \eta)$ is a monoid.

3. In the previous situation, the left regular representation π_l lives in $\text{Rep}_f(A, \Delta)$ iff A is finite dimensional. This already suggests that the category \mathcal{C} in general is too small to contain a monoid of the desired properties. In fact, assume we can take $\widehat{\mathcal{C}} = \mathcal{C}$. Then for every irreducible $X \in \mathcal{C}$ we have $\dim \text{Hom}(X, Q) = \dim \text{Hom}(\mathbf{1}, Q \otimes \overline{X}) = n(\overline{X}) > 0$. Thus Q contains all irreducible objects as direct summands. Since every object in \mathcal{C} is a finite direct sum of simple objects, $\widehat{\mathcal{C}} = \mathcal{C}$ is possible only if \mathcal{C} has only finitely many isomorphism classes of simple objects. In fact, even in this case, our construction of (Q, m, η) will require the use of a bigger category $\widehat{\mathcal{C}}$. It is here that the category $\text{Ind } \mathcal{C}$ of Subsection A.7 comes into play.

Since we have already reduced the problem of constructing a fiber functor to the case of finitely generated tensor categories, we want a version of the preceding result adapted to that situation:

COROLLARY 415. *Let \mathcal{C} be a TC^* with monoidal generator $Z \in \mathcal{C}$ and let $\widehat{\mathcal{C}}$ be a \mathbb{C} -linear strict tensor category containing \mathcal{C} as a full tensor subcategory. If (Q, m, η) is a monoid in $\widehat{\mathcal{C}}$ satisfying*

(i) $\dim \text{Hom}_{\widehat{\mathcal{C}}}(\mathbf{1}, Q) = 1$.

(ii) *There is $d \in \mathbb{N}$ and an isomorphism $\alpha_Z : (Q \otimes Z, m \otimes \text{id}_Z) \rightarrow d \cdot (Q, m)$ of Q -modules.*

Then the hypothesis (ii) in Proposition 413 follows. Thus $E : X \mapsto \text{Hom}_{\widehat{\mathcal{C}}}(\mathbf{1}, Q \otimes X)$ is a fiber functor.

Proof. If $X \in \mathcal{C}$, there exists $n \in \mathbb{N}$ such that $X \prec Z^{\otimes n}$. Concretely, there are morphisms $u : X \rightarrow Z^{\otimes n}$ and $v : Z^{\otimes n} \rightarrow X$ such that $v \circ u = \text{id}_X$. Then the morphisms $\tilde{u} = \text{id}_Q \otimes u : Q \otimes X \rightarrow Q \otimes Z^{\otimes n}$ and $\tilde{v} = \text{id}_Q \otimes v : Q \otimes Z^{\otimes n} \rightarrow Q \otimes X$ are morphisms of Q -modules. Thus the Q -module $(Q \otimes X, m \otimes \text{id}_X)$ is a direct summand of $(Q \otimes Z^{\otimes n}, m \otimes \text{id}_{Z^{\otimes n}})$. By assumption, the latter is isomorphic to a direct sum of d^n copies of (Q, m) . By Lemma 358 and assumption

(i), $\text{End}_Q((Q, m)) \cong \mathbb{C}$, thus $(Q, m) \in Q - \text{Mod}$ is irreducible. Thus the direct summand $(Q \otimes X, m \otimes \text{id}_X)$ of $d^n \cdot (Q, m)$ is a direct sum of r copies of (Q, m) with $r \leq d^m$ and $r \neq 0$ whenever $X \neq 0$. Thus hypothesis (ii) in Proposition 413 holds. ■

In view of Corollary 415, proving Theorem 411 amounts to finding a symmetric tensor category $\widehat{\mathcal{C}}$ containing \mathcal{C} as a full subcategory and a commutative monoid (Q, m, η) in $\widehat{\mathcal{C}}$ such that $\dim \text{Hom}(\mathbf{1}, Q) = 1$ and $Q \otimes Z \cong d \otimes Q$ as Q -modules for a suitable monoidal generator Z of \mathcal{C} . This will be achieved in Subsection B.11, based on thorough analysis of the permutation symmetry of the category \mathcal{C} .

B.9 Symmetric group action, determinants and integrality of dimensions

We now turn to a discussion of certain representations of the symmetric groups $P_n, n \in \mathbb{N}$, present in tensor $*$ -categories with a unitary symmetry. It is well known that the symmetric group P_n on n labels has the presentation

$$P_n = (\sigma_1, \dots, \sigma_{n-1} \mid |i - j| \geq 2 \Rightarrow \sigma_i \sigma_j = \sigma_j \sigma_i, \\ \sigma_i \sigma_{i+1} \sigma_i = \sigma_{i+1} \sigma_i \sigma_{i+1} \ \forall i \in \{1, \dots, n - 1\}, \ \sigma_i^2 = 1 \ \forall i).$$

Since \mathcal{C} is strict we may define the tensor powers $X^{\otimes n}, n \in \mathbb{N}$, in the obvious way for any $X \in \mathcal{C}$. We posit $X^{\otimes 0} = \mathbf{1}$ for every $X \in \mathcal{C}$.

LEMMA 416. *Let \mathcal{C} be an STC*. Let $X \in \mathcal{C}$ and $n \in \mathbb{N}$. Then*

$$\Pi_n^X : \sigma_i \mapsto \text{id}_{X^{\otimes i-1}} \otimes c_{X,X} \otimes \text{id}_{X^{\otimes n-i-1}}$$

uniquely determines a homomorphism Π_n^X from the group P_n into the unitary group of $\text{End } X^{\otimes n}$.

Proof. It is clear that $\Pi_n^X(\sigma_i)$ and $\Pi_n^X(\sigma_j)$ commute if $|i - j| \geq 2$. That $\Pi_n^X(\sigma_i)^2 = \text{id}_{X^{\otimes n}}$ is equally obvious. Finally,

$$\Pi_n^X(\sigma_i) \circ \Pi_n^X(\sigma_{i+1}) \circ \Pi_n^X(\sigma_i) = \Pi_n^X(\sigma_{i+1}) \circ \Pi_n^X(\sigma_i) \circ \Pi_n^X(\sigma_{i+1})$$

follows from the Yang-Baxter equation satisfied by the symmetry c . ■

REMARK 417. Dropping the relations $\sigma_i^2 = 1$ the same formulae as above define homomorphisms of the Artin braid groups B_n into $\text{End } X^{\otimes n}$. However, none of the following considerations has known analogues in the braided case.

Recall that there is a homomorphism $\text{sgn} : P_n \rightarrow \{1, -1\}$, the signature map.

LEMMA 418. *Let \mathcal{C} be an STC*. For any $X \in \mathcal{C}$ we define orthogonal projections in $\text{End } X^{\otimes 0} = \text{End } \mathbf{1}$ by $S_0^X = A_0^X = \text{id}_{\mathbf{1}}$. For any $n \in \mathbb{N}$, the morphisms*

$$S_n^X = \frac{1}{n!} \sum_{\sigma \in P_n} \Pi_n^X(\sigma), \\ A_n^X = \frac{1}{n!} \sum_{\sigma \in P_n} \text{sgn}(\sigma) \Pi_n^X(\sigma)$$

satisfy

$$\begin{aligned} \Pi_n^X(\sigma) \circ S_n^X &= S_n^X \circ \Pi_n^X(\sigma) = S_n^X, \\ \Pi_n^X(\sigma) \circ A_n^X &= A_n^X \circ \Pi_n^X(\sigma) = \text{sgn}(\sigma) A_n^X \end{aligned}$$

for all $\sigma \in P_n$ and are thus orthogonal projections in the $*$ -algebra $\text{End } X^{\otimes n}$.

Proof. Straightforward computations. ■

DEFINITION 419. The subobjects (defined up to isomorphism) of $X^{\otimes n}$ corresponding to the idempotents S_n^X and A_n^X are denoted by $S_n(X)$ and $A_n(X)$, respectively.

The following was proven both in [Doplicher and Roberts, 1989] and [Deligne, 1990]:

PROPOSITION 420. *Let \mathcal{C} be an even STC*. For any $X \in \mathcal{C}$ we have*

$$(62) \quad \text{Tr}_{X^{\otimes n}} A_n^X = \frac{d(X)(d(X) - 1)(d(X) - 2) \cdots (d(X) - n + 1)}{n!} \quad \forall n \in \mathbb{N}.$$

Proof. (*Sketch*) Making crucial use of the fact that \mathcal{C} is even, i.e. $\Theta(X) = \text{id}_X$ for all $X \in \mathcal{C}$, one can prove

$$\text{Tr}_{X^{\otimes n}} \Pi_n^X(\sigma) = d(X)^{\#\sigma} \quad \forall X \in \mathcal{C}, \sigma \in P_n,$$

where $\#\sigma$ is the number of cycles into which the permutation σ decomposes. (The reader familiar with tangle diagrams will find this formula almost obvious: Triviality of the twist $\Theta(X)$ implies invariance under the first Reidemeister move. Thus the closure of the permutation σ is equivalent to $\#\sigma$ circles, each of which contributes a factor $d(X)$.) Now the result follows at once from the definition of A_n^X and the formula

$$\sum_{\sigma \in P_n} \text{sgn}(\sigma) z^{\#\sigma} = z(z - 1)(z - 2) \cdots (z - n + 1),$$

which holds for all $n \in \mathbb{N}$ and $z \in \mathbb{C}$, as one can prove by induction over n . ■

COROLLARY 421. *In an STC* we have $d(X) \in \mathbb{N}$ for every non-zero $X \in \mathcal{C}$.*

Proof. Assume first that \mathcal{C} is even, and let $X \in \mathcal{C}$. Since \mathcal{C} has subobjects there exist an object $A_n(X) \in \mathcal{C}$ and a morphism $s : A_n(X) \rightarrow X^{\otimes n}$ such that $s^* \circ s = \text{id}_{A_n(X)}$ and $s \circ s^* = A_n^X$. Then by part 1 and 2 in Proposition 339, we get

$$\text{Tr}_{X^{\otimes n}} A_n^X = \text{Tr}_{X^{\otimes n}}(s \circ s^*) = \text{Tr}_{A_n(X)}(s^* \circ s) = \text{Tr}_{A_n(X)} \text{id}_{A_n(X)} = d(A_n(X)).$$

Since the dimension of any object in a $*$ -category is non-negative we thus conclude that $\text{Tr}_{X^{\otimes n}} A_n^X \geq 0$ for all $n \in \mathbb{N}$. From the right-hand side in the formula (62)

for $Tr_{X^{\otimes n}} A_n^X$ we see that $Tr_{X^{\otimes n}} A_n^X$ will become negative for some $n \in \mathbb{N}$ unless $d(X) \in \mathbb{N}$.

If \mathcal{C} is odd, the above argument gives integrality of the dimensions in the bosonized category $\tilde{\mathcal{C}}$. Since the categorical dimension is independent of the braiding, we have $d_{\mathcal{C}}(X) = d_{\tilde{\mathcal{C}}}(X)$ and are done. ■

Let \mathcal{C} be an STC^* and $X \in \mathcal{C}$ non-zero and set $d = d(X) \in \mathbb{N}$. Consider the subobject $A_d(X)$ of $X^{\otimes d}$, introduced in the proof of Corollary 421, which corresponds to the orthogonal projection $A_d^X \in \text{End } X^{\otimes d}$ defined in Lemma 418. Then

$$d(A_d(X)) = Tr_{X^{\otimes d}} A_d^X = \frac{d!}{d!} = 1,$$

we see that $A_d(X)$ is an irreducible and invertible object of \mathcal{C} (with inverse $\overline{A_d(X)}$).

DEFINITION 422. The isomorphism class of $A^{d(X)}(X)$ is called the *determinant* $\det X$ of X .

LEMMA 423. Let \mathcal{C} be an STC^* and $X, Y \in \mathcal{C}$. Then

- (i) $\det \overline{X} \cong \overline{\det(X)}$.
- (ii) $\det(X \oplus Y) \cong \det X \otimes \det Y$.
- (iii) $\det(X \oplus \overline{X}) \cong \mathbf{1}$.

Proof. (i) Let $(\overline{X}, r, \bar{r})$ be a standard left inverse of X . By inductive use of Lemma 338 one obtains standard left inverses $(\overline{X}^{\otimes n}, r_n, \bar{r}_n)$ of $X^{\otimes n}$ for any $n \in \mathbb{N}$. If now $\sigma = \sigma_{i_1} \cdots \sigma_{i_r} \in P_n$, one can verify that

$$\Pi_n^{\overline{X}}(\sigma') = r_n^* \otimes \text{id}_{\overline{X}^{\otimes n}} \circ \text{id}_{\overline{X}^{\otimes n}} \otimes \Pi_n^X(\sigma) \otimes \text{id}_{\overline{X}^{\otimes n}} \circ \text{id}_{\overline{X}^{\otimes n}} \otimes \bar{r}_n,$$

where $\sigma' = \sigma_{n-i_r}^{-1} \cdots \sigma_{n-i_1}^{-1}$. In particular, $\text{sgn } \sigma' = \text{sgn } \sigma$, implying

$$A_n^{\overline{X}} = r_n^* \otimes \text{id}_{\overline{X}^{\otimes n}} \circ \text{id}_{\overline{X}^{\otimes n}} \otimes A_n^X \otimes \text{id}_{\overline{X}^{\otimes n}} \circ \text{id}_{\overline{X}^{\otimes n}} \otimes \bar{r}_n,$$

for any $n \in \mathbb{N}$. Now the claim follows from Lemma 337.

(ii) For any $X \in \mathcal{C}$ we abbreviate $d_X = d(X)$ and $A^X = A_{d_X}^X \in \text{End } X^{\otimes d_X}$. Let $u : X \rightarrow Z, v : Y \rightarrow Z$ be isometries implementing $Z \cong X \oplus Y$. Then $X^{\otimes d_X}$ is a subobject of $Z^{\otimes d_X}$, and similarly for $Y^{\otimes d_Y}$. By definition, $\det Z$ is the subobject of $Z^{\otimes d_Z}$ corresponding to the projector $A^Z \in \text{End } Z^{\otimes d_Z}$. On the other hand, $\det X \otimes \det Y$ is the subobject of $X^{\otimes d_X} \otimes Y^{\otimes d_Y}$ corresponding to the projector $A^X \otimes A^Y$, and therefore it is isomorphic to the subobject of $Z^{\otimes d_Z}$ corresponding to the projector

$$u \otimes \cdots \otimes u \otimes v \otimes \cdots \otimes v \circ A^X \otimes A^Y \circ u^* \otimes \cdots \otimes u^* \otimes v^* \otimes \cdots \otimes v^* \in \text{End } Z^{\otimes d_Z},$$

where there are d_X factors u and u^* and d_Y factors v and v^* . This equals

$$\frac{1}{d_X!d_Y!} \sum_{\substack{\sigma \in P_{d_X} \\ \sigma' \in P_{d_Y}}} \text{sgn}(\sigma)\text{sgn}(\sigma') u \otimes \cdots \otimes u \otimes v \otimes \cdots \otimes v \\ \circ \Pi_{d_X}^X(\sigma) \otimes \Pi_{d_Y}^Y(\sigma') \circ u^* \otimes \cdots \otimes u^* \otimes v^* \otimes \cdots \otimes v^*.$$

By naturality of the braiding, this equals

$$\frac{1}{d_X!d_Y!} \sum_{\substack{\sigma \in P_{d_X} \\ \sigma' \in P_{d_Y}}} \text{sgn}(\sigma)\text{sgn}(\sigma') \Pi_{d_X}^Z(\sigma) \otimes \Pi_{d_Y}^Z(\sigma') \circ p_X \otimes \cdots \otimes p_X \otimes p_Y \otimes \cdots \otimes p_Y,$$

where $p_X = u \circ u^*, p_Y = v \circ v^*$. With the juxtaposition $\sigma \times \sigma' \in P_{d_X+d_Y} = P_{d_Z}$ of σ and σ' this becomes

$$(63) \quad \frac{1}{d_X!d_Y!} \sum_{\substack{\sigma \in P_{d_X} \\ \sigma' \in P_{d_Y}}} \text{sgn}(\sigma \times \sigma') \Pi_{d_Z}^Z(\sigma \times \sigma') \circ p_X \otimes \cdots \otimes p_X \otimes p_Y \otimes \cdots \otimes p_Y.$$

On the other hand,

$$\begin{aligned} A^Z &= \frac{1}{d_Z!} \sum_{\sigma \in P_{d_Z}} \text{sgn}(\sigma) \Pi_{d_Z}^Z(\sigma) \\ &= \left(\sum_{\sigma \in P_{d_Z}} \text{sgn}(\sigma) \Pi_{d_Z}^Z(\sigma) \right) \circ (p_X + p_Y) \otimes \cdots \otimes (p_X + p_Y). \end{aligned}$$

Of the 2^{d_Z} terms into which this can be decomposed, only those with d_X factors p_X and d_Y factors p_Y are nonzero since $A_n^X = 0$ for $n > d_X$ and $A_n^Y = 0$ for $n > d_Y$. We are thus left with a sum of $d_Z!/d_X!d_Y!$ terms, and working out the signs we see that they all equal to $d_X!d_Y!/d_Z!$ times (63), thus the sum equals (63). This proves the isomorphism $\det Z \cong \det X \otimes \det Y$.

Finally, (iii) follows from

$$\det(X \oplus \overline{X}) \cong \det X \otimes \det \overline{X} \cong \det X \otimes \overline{\det X} \cong \det X \otimes (\det X)^{-1} \cong \mathbf{1},$$

where we have used (i) and (ii) of this lemma, $d(\det X) = 1$ and (iii) of Lemma 341. ■

For later use we state a computational result:

LEMMA 424. *Let X satisfy $\det X \cong \mathbf{1}$ and write $d = d(X)$. If $s : \mathbf{1} \rightarrow X^{\otimes d}$ is an isometry for which $s \circ s^* = A_d^X$ then*

$$(64) \quad s^* \otimes \text{id}_X \circ \text{id}_X \otimes s = (-1)^{d-1} d^{-1} \text{id}_X.$$

Proof. We abbreviate $x = s^* \otimes \text{id}_X \circ \text{id}_X \otimes s$ and observe that by non-degeneracy of the trace it is sufficient to show that $\text{Tr}_X(ax) = (-1)^{d-1}d^{-1}\text{Tr}_X(a)$ for all $a \in \text{End}X$. In order to show this, let (\bar{X}, r, \bar{r}) be a standard solution of the conjugate equations and compute

$$\begin{aligned}
 \text{Tr}_X(ax) &= \text{Diagram 1} = (-1)^{d-1} \text{Diagram 2} \\
 &= (-1)^{d-1} \text{Diagram 3} = (-1)^{d-1} \text{Diagram 4}
 \end{aligned}$$

We have in turn used the total antisymmetry of s (Lemma 418), the naturality properties of the braiding and the triviality of the twist Θ_X . Now,

$$\begin{aligned}
 s^* \circ a \otimes \text{id}_{X^{\otimes d-1}} \circ s &= \text{Tr}_1(s^* \circ a \otimes \text{id}_{X^{\otimes d-1}} \circ s) \\
 &= \text{Tr}_{X^{\otimes d}}(a \otimes \text{id}_{X^{\otimes d-1}} \circ s \circ s^*) = \text{Tr}_{X^{\otimes d}}(a \otimes \text{id}_{X^{\otimes d-1}} \circ A_d^X).
 \end{aligned}$$

In order to complete the proof we need to show that this equals $d^{-1}\text{Tr}_X a$, which is done by suitably modifying the proof of Proposition 420. By the same argument as given there, it suffices to prove $\text{Tr}_{X^{\otimes d}}(a \otimes \text{id}_{X^{\otimes d-1}} \circ \Pi_d^X(\sigma)) = d^{\#\sigma-1}\text{Tr}_X a$. Again, the permutation σ decomposes into a set of cyclic permutations, of which now precisely one involves the index 1. It is therefore sufficient to prove $\text{Tr}_{X^{\otimes n}}(a \otimes \text{id}_{X^{\otimes n-1}} \circ \Pi_n^X(\sigma)) = \text{Tr}_X a$ for every cyclic permutation σ of all n indices. Inserting a at the appropriate place, the calculation essentially proceeds as before. The only difference is that instead of $\text{Tr}_X \text{id}_X = d(X)$ one is left with $\text{Tr}_X a$, giving rise to the desired result. ■

REMARK 425. Objects with determinant $\mathbf{1}$ were called special in [Doplicher and Roberts, 1989], where also all results of this subsection can be found.

This concludes our discussion of antisymmetrization and determinants, and we turn to symmetrization and the symmetric algebra. It is here that we need the Ind-category that was introduced in Subsection A.7.

B.10 The symmetric algebra

In “ordinary” algebra one defines the symmetric algebra $S(V)$ over a vector space V . Unless $V = \{0\}$, this is an infinite direct sum of non-trivial vector spaces. We will need a generalization of this construction to symmetric tensor categories other than Vect. While infinite direct sums of objects make sense in the setting of C^* -tensor categories (Definition 345), a more convenient setting for the following considerations is given by the theory of abelian categories.

LEMMA 426. *Let \mathcal{C} be an STC* and $X \in \mathcal{C}$. For every $n \in \mathbb{N}$ choose an object $S_n(X)$ and an isometry $u_n : S_n(X) \rightarrow X^{\otimes n}$ such that $u_n \circ u_n^* = S_n^X$. Also, let $u_0 = \text{id}_{\mathbf{1}}$, interpreted as a morphism from $S_0(X) = \mathbf{1}$ to $X^0 = \mathbf{1}$. The morphisms $m_{i,j} : S_i(X) \otimes S_j(X) \rightarrow S_{i+j}(X)$ defined by*

$$m_{i,j} : S_i(X) \otimes S_j(X) \xrightarrow{u_i \otimes u_j} X^{\otimes i} \otimes X^{\otimes j} \equiv X^{\otimes(i+j)} \xrightarrow{u_{i+j}^*} S_{i+j}(X)$$

satisfy

$$m_{i+j,k} \circ m_{i,j} \otimes \text{id}_{S_k(X)} = m_{i,j+k} \circ \text{id}_{S_i(X)} \otimes m_{j,k}$$

for all $i, j, k \in \mathbb{Z}_+$. Furthermore,

$$m_{i,j} = m_{j,i} \circ c_{S_i(X), S_j(X)} \quad \forall i, j$$

and $m_{i,0} = m_{0,i} = \text{id}_{S_i(X)}$.

Proof. As a consequence of $S_n^X \circ \Pi_n^X(\sigma) = S_n^X(\sigma)$ for all $\sigma \in P_n$, cf. Lemma 418, we have

$$S_{i+j+k}^X \circ S_{i+j}^X \otimes \text{id}_{X^{\otimes k}} \circ S_i^X \otimes S_j^X \otimes \text{id}_{X^{\otimes k}} = S_{i+j+k}^X \circ S_{i+j}^X \otimes \text{id}_{X^{\otimes k}} = S_{i+j+k}^X,$$

$$S_{i+j+k}^X \circ \text{id}_{X^{\otimes k}} \otimes S_{j+k}^X \circ \text{id}_{X^{\otimes i}} \otimes S_j^X \otimes S_k^X = S_{i+j+k}^X \circ \text{id}_{X^{\otimes i}} \otimes S_{j+k}^X = S_{i+j+k}^X.$$

Multiplying all this with u_{i+j+k}^* on the left and with $u_i \otimes u_j \otimes u_k$ on the right and using $u_i^* \circ S_i^X = u_n^*$ and $S_i^X \circ u_i = u_i$ this implies

$$\begin{aligned} u_{i+j+k}^* \circ S_{i+j}^X \otimes \text{id}_{X^{\otimes k}} \circ u_i \otimes u_j \otimes u_k &= u_{i+j+k}^* \circ u_i \otimes u_j \otimes u_k \\ &= u_{i+j+k}^* \circ \text{id}_{X^{\otimes k}} \otimes S_{j+k}^X \circ u_i \otimes u_j \otimes u_k. \end{aligned}$$

Using again that $S_{i+j}^X = u_{i+j} \circ u_{i+j}^*$, we have the first identity we wanted to prove. Furthermore,

$$\begin{aligned} m_{j,i} \circ c_{S_i(X), S_j(X)} &= u_{i+j}^* \circ u_j \otimes u_i \circ c_{S_i(X), S_j(X)} = u_{i+j}^* \circ c_{X^{\otimes i}, X^{\otimes j}} \circ u_i \otimes u_j \\ &= u_{i+j}^* \circ \Pi_{i+j}^X(\sigma) \circ u_i \otimes u_j = u_{i+j}^* \circ S_{i+j}^X \circ \Pi_{i+j}^X(\sigma) \circ u_i \otimes u_j \\ &= u_{i+j}^* \circ S_{i+j}^X \circ u_i \otimes u_j = u_{i+j}^* \circ u_i \otimes u_j = m_{i,j}, \end{aligned}$$

where $\sigma \in P_{i+j}$ is the permutation exchanging the first i with the remaining j strands. The last claim is obvious in view of $S_0(X) = \mathbf{1}$. ■

In view of Lemma 353, \mathcal{C} (with a zero object thrown in) is an abelian category, thus there exists an abelian \mathbb{C} -linear strict symmetric tensor category $\text{Ind } \mathcal{C}$ containing \mathcal{C} as a full subcategory and complete w.r.t. filtered inductive limits. Therefore, for any object X in the STC^* \mathcal{C} , there exists an object

$$S(X) = \lim_{n \rightarrow \infty} \bigoplus_{i=0}^n S_n(X)$$

together with monomorphisms $v_n : S_n(X) \rightarrow S(X)$.

PROPOSITION 427. *Let \mathcal{C} be an STC^* and $X \in \mathcal{C}$. Then there exists a morphism $m_{S(X)} : S(X) \otimes S(X) \rightarrow S(X)$ such that*

$$m_{S(X)} \circ v_i \otimes v_j = v_{i+j} \circ m_{i,j} : S_i(X) \otimes S_j(X) \rightarrow S(X)$$

and $(S(X), m_{S(X)}, \eta_{S(X)} \equiv v_0)$ is a commutative monoid in $\text{Ind } \mathcal{C}$.

Proof. This amounts to using

$$\text{Hom}_{\text{Ind } \mathcal{C}}(S(X) \otimes S(X), S(X)) = \varinjlim_m \varinjlim_n \text{Hom}_{\mathcal{C}} \left(\bigoplus_{i,j=0}^m S_i(X) \otimes S_j(X), \bigoplus_{k=0}^n S_k(X) \right)$$

to assemble the morphisms $m_{i,j} : S_i(X) \otimes S_j(X) \rightarrow S_{i+j}(X)$ into one big morphism $S(X) \otimes S(X) \rightarrow S(X)$. We omit the tedious but straightforward details. Associativity ($m_{S(X)} \circ m_{S(X)} \otimes \text{id}_{S(X)} = m_{S(X)} \circ \text{id}_{S(X)} \otimes m_{S(X)}$) and commutativity ($m_{S(X)} = m_{S(X)} \circ c_{S(X), S(X)}$) then follow from the respective properties of the $m_{i,j}$ established in Lemma 426. The unit property $m_{S(X)} \circ \text{id}_{S(X)} \otimes v_0 = \text{id}_{S(X)} \otimes v_0 = \text{id}_{S(X)}$ follows from $m_{i,0} = m_{0,i} = \text{id}_{S_i(X)}$. ■

We now study the interaction between the operations of symmetrization and antisymmetrization, i.e. between determinants and symmetric algebras, that lies at the core of the embedding theorem. We begin by noting that given two commutative monoids (Q_i, m_i, η_i) , $i = 1, 2$ in a strict symmetric tensor category, the triple $(Q_1 \otimes Q_2, m_{Q_1 \otimes Q_2}, \eta_{Q_1 \otimes Q_2})$, where $\eta_{Q_1 \otimes Q_2} = \eta_1 \otimes \eta_2$ and

$$m_{Q_1 \otimes Q_2} = m_1 \otimes m_2 \circ \text{id}_{Q_1} \otimes c_{Q_2, Q_1} \otimes \text{id}_{Q_2},$$

defines a commutative monoid, the direct product $(Q_1, m_1, \eta_1) \times (Q_2, m_2, \eta_2)$. The direct product \times is strictly associative, thus multiple direct products are unambiguously defined by induction.

LEMMA 428. *Let \mathcal{C} be a STC and assume $Z \in \mathcal{C}$ satisfies $\det Z \cong \mathbf{1}$. We write $d = d(Z)$ and pick $s : \mathbf{1} \rightarrow Z^{\otimes d}$, $s' : Z^{\otimes d} \rightarrow \mathbf{1}$ such that $s' \circ s = \text{id}_{\mathbf{1}}$ and $s \circ s' = A_d^Z$. Let $S(Z)$ be the symmetric tensor algebra over Z with the canonical embeddings $v_0 : \mathbf{1} \rightarrow S(Z), v_1 : Z \rightarrow S(Z)$. Consider the commutative monoid structure on $Q = S(Z)^{\otimes d}$ given by*

$$(Q, m_Q, \eta_Q) = (S(Z), m_{S(Z)}, \eta_{S(Z)})^{\times d}.$$

Define morphisms $f : \mathbf{1} \rightarrow Q$ and $u_i : Z \rightarrow Q$, $t_i : Z^{\otimes(d-1)} \rightarrow Q$, $i = 1, \dots, d$ by

$$f = \underbrace{v_1 \otimes \dots \otimes v_1}_{d \text{ factors}} \circ s,$$

$$u_i = \underbrace{v_0 \otimes \dots \otimes v_0}_{i-1 \text{ factors}} \otimes v_1 \otimes \underbrace{v_0 \otimes \dots \otimes v_0}_{d-i \text{ factors}},$$

$$t_i = (-1)^{d-i} \underbrace{v_1 \otimes \dots \otimes v_1}_{i-1 \text{ factors}} \otimes v_0 \otimes \underbrace{v_1 \otimes \dots \otimes v_1}_{d-i \text{ factors}}.$$

Then s, f, u_i, t_j satisfy

$$(65) \quad m_Q \circ t_j \otimes u_i \circ s = \delta_{ij} f \quad \forall i, j \in \{1, \dots, d\}.$$

Proof. First note that $s : \mathbf{1} \rightarrow Z^{\otimes d}$ as required exists since $\det Z \cong \mathbf{1}$ and that f is a composition of monics, thus non-zero. We compute

$$\begin{aligned} m_Q \circ t_i \otimes u_i \circ s &= (-1)^{d-i} \text{id}_{S(Z)^{\otimes(i-1)}} \otimes c_{S(Z)^{\otimes(d-i)}, S(Z)} \circ v_1 \otimes v_1 \otimes \dots \otimes v_1 \circ s \\ &= (-1)^{d-i} v_1 \otimes v_1 \otimes \dots \otimes v_1 \circ \text{id}_{Z^{\otimes(i-1)}} \otimes c_{Z^{\otimes(d-i)}, Z} \circ s \\ &= v_1 \otimes v_1 \otimes \dots \otimes v_1 \circ s \\ &= f. \end{aligned}$$

In the first equality we used the definition of (Q, m_Q, η_Q) as d -fold direct product of $(S(Z), m_{S(Z)}, \eta_{S(Z)})$ and the fact that $v_0 = \eta_{S(Z)}$ is the unit, naturality of the braiding in the second and Lemma 418 in the third. To see that $m_Q \circ t_j \otimes u_i \circ s = 0$ if $i \neq j$ consider $j = d - 1, i = d$. Then $m_Q \circ t_j \otimes u_i \circ s : \mathbf{1} \rightarrow S(Z)^{\otimes d} \cong Q$ is the composite

$$\mathbf{1} \xrightarrow{s} Z^{\otimes d} \xrightarrow{\underbrace{v_1 \otimes \dots \otimes v_1}_{d-2 \text{ factors}} \otimes v_0 \otimes v_1 \otimes v_1} S(Z)^{\otimes(d+1)} \xrightarrow{\text{id}_{S(Z)^{\otimes(d-1)}} \otimes m_{S(Z)}} S(Z)^{\otimes d}.$$

Now,

$$\begin{aligned}
 & \text{id}_{S(Z)^{\otimes(d-1)}} \otimes m_{S(Z)} \circ v_1 \otimes \cdots \otimes v_1 \otimes v_0 \otimes v_1 \otimes v_1 \circ s \\
 &= \text{id}_{S(Z)^{\otimes(d-1)}} \otimes (m_{S(Z)} \circ c_{S(Z),S(Z)}) \circ v_1 \otimes \cdots \otimes v_1 \otimes v_0 \otimes v_1 \otimes v_1 \circ s \\
 &= \text{id}_{S(Z)^{\otimes(d-1)}} \otimes m_{S(Z)} \circ \text{id}_{S(Z)^{\otimes(d-1)}} \otimes c_{S(Z),S(Z)} \\
 &\quad \circ v_1 \otimes \cdots \otimes v_1 \otimes v_0 \otimes v_1 \otimes v_1 \circ s \\
 &= \text{id}_{S(Z)^{\otimes(d-1)}} \otimes m_{S(Z)} \circ v_1 \otimes \cdots \otimes v_1 \otimes v_0 \otimes v_1 \otimes v_1 \circ \text{id}_{Z^{\otimes(d-2)}} \otimes c_{Z,Z} \circ s \\
 &= - \text{id}_{S(Z)^{\otimes(d-1)}} \otimes m_{S(Z)} \circ v_1 \otimes \cdots \otimes v_1 \otimes v_0 \otimes v_1 \otimes v_1 \circ s,
 \end{aligned}$$

where we used the commutativity of $m_{S(Z)}$ in the first step and the total antisymmetry of s in the last. Thus $m_Q \circ u_d \otimes t_{d-1} \circ s = -m_Q \circ u_d \otimes t_{d-1} \circ s = 0$. For general $i \neq j$ the argument is exactly the same, but becomes rather tedious to write up in detail. ■

REMARK 429. Lemma 428 and Proposition 430 below, both taken from [Bichon, 1998], are the crucial ingredients in our approach to the reconstruction theorem.

B.11 Construction of an absorbing commutative monoid

Throughout this subsection, let \mathcal{C} be an even STC^* with monoidal generator Z . Consider the commutative monoid $(Q, m, \eta) = (S(Z), m_{S(Z)}, \eta_{S(Z)})^{\times d(Z)}$ in $\text{Ind } \mathcal{C}$ and the morphisms s, s', f, u_i, t_j as defined in Lemma 428. Then $m_0 \in \text{End } Q$ defined by

$$m_0 = m_Q \circ \text{id}_Q \otimes (f - \eta_Q) = m_Q \circ \text{id}_Q \otimes f - \text{id}_Q$$

is a Q -module map, thus $m_0 \in \text{End}_Q((Q, m_Q))$. Then its image $j = \text{im } m_0 : (J, \mu_J) \rightarrow (Q, m_Q)$ (in the abelian category $Q\text{-Mod}$) defines an ideal $j : (J, \mu_J) \rightarrow (Q, m)$ in (Q, m, η) . This ideal is proper iff j is not an isomorphism iff m_0 is not an isomorphism. Postponing this issue for a minute, we have:

PROPOSITION 430. *Let \mathcal{C} be an even symmetric STC^* and let $Z \in \mathcal{C}$ be such that $\det Z \cong \mathbf{1}$. Let (Q, m, η) and s, s', f, u_i, t_j be as defined in Lemma 428 and m_0 as above. Let $j' : (J', \mu') \rightarrow (Q, m)$ be any proper ideal in (Q, m, η) containing the ideal $j : (J, \mu) \rightarrow (Q, m)$, where $j = \text{im } m_0$. Let (B, m_B, η_B) be the quotient monoid. Then there is an isomorphism*

$$(B \otimes Z, m \otimes \text{id}_Z) \cong d(Z) \cdot (B, m_B)$$

of B -modules.

Proof. Since the ideal is proper, the quotient (B, m_B, η_B) is nontrivial and we have an epi $p : Q \rightarrow B$ satisfying

$$(66) \quad p \circ m_Q = m_B \circ p \otimes p,$$

$$(67) \quad p \circ f = p \circ \eta_Q = \eta_B.$$

In order to prove the claimed isomorphism $B \otimes Z \cong d B$ of B -modules we define morphisms $\tilde{q}_i \in \text{Hom}(\mathbf{1}, B \otimes Z)$, $\tilde{p}_i \in \text{Hom}(Z, B)$, $i = 1, \dots, d$ as the following compositions:

$$\begin{aligned} \tilde{q}_i &: \mathbf{1} \xrightarrow{s} Z^{\otimes d} \cong Z^{\otimes(d-1)} \otimes Z \xrightarrow{t_i \otimes \text{id}_Z} Q \otimes Z \xrightarrow{p \otimes \text{id}_Z} B \otimes Z, \\ \tilde{p}_i &: Z \xrightarrow{u_i} Q \xrightarrow{p} B. \end{aligned}$$

Using, first (66), then (65) and (67) we compute

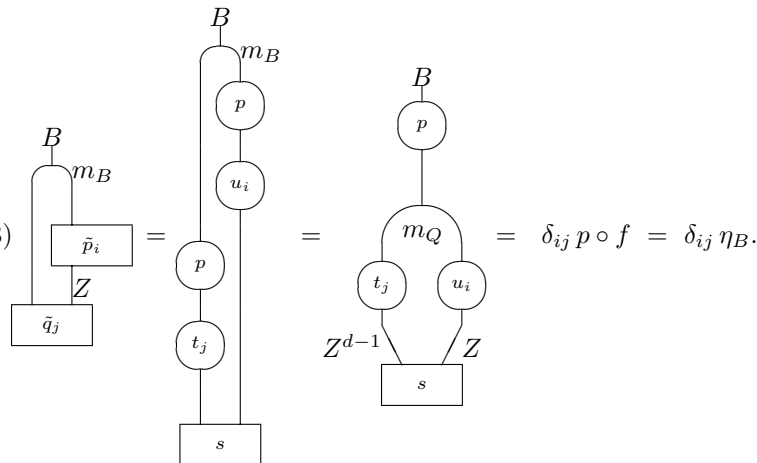
(68) 

Defining, for $i = 1, \dots, d$,

$$q_i = \text{Diagram with } B \text{ and } Z \text{ inputs and } B \text{ output, containing } m_B \text{ and } \tilde{q}_i \text{ boxes.}$$

$$p_i = \text{Diagram with } B \text{ and } Z \text{ inputs and } B \text{ output, containing } m_B \text{ and } \tilde{p}_i \text{ boxes.}$$

we find

$$p_i \circ q_j = \text{Diagram with } B \text{ and } B \text{ inputs and } B \text{ output, containing } m_B \text{ and } \tilde{q}_j \text{ boxes.} = \delta_{ij} m_B \text{ diagram} = \delta_{ij} \text{id}_B,$$

where in the next to last step we used (68). It is obvious from their definitions that p_i, q_i are morphisms of B -modules. We have thus shown that the B -module $(B \otimes Z, m_B \otimes \text{id}_Z)$ has d direct summands (B, m_B) , and therefore

$$(B \otimes Z, m_B \otimes \text{id}_Z) \cong \underbrace{(B, m_B) \oplus \dots \oplus (B, m_B)}_{d \text{ summands}} \oplus (N, \mu_N).$$

It remains to be shown that $N = 0$ or, equivalently, $\sum_{i=1}^d q_i \circ p_i = \text{id}_{B \otimes Z}$. A short argument to this effect is given in [Deligne, 1990; Bichon, 1998], but since it is somewhat abstract we give a pedestrian computational proof. We calculate

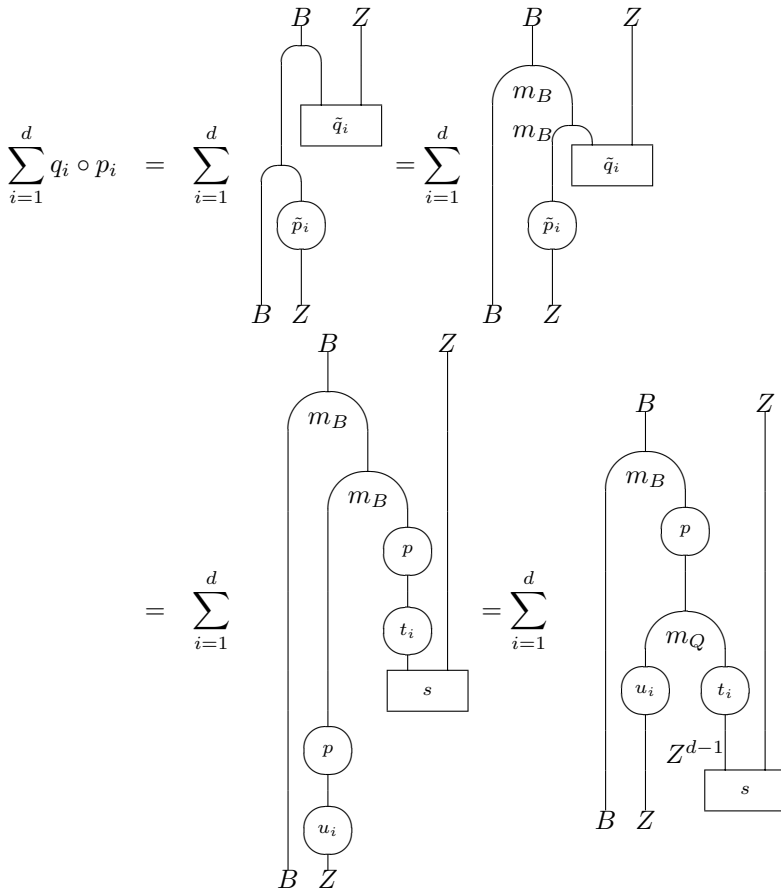

Composition with $\eta_B \otimes \text{id}_Z$ shows that this equals $\text{id}_{B \otimes Z}$ iff

$$(69) \quad \sum_{i=1}^d \begin{array}{c} B \\ \circ \\ p \\ \circ \\ m_Q \\ \circ \\ \begin{array}{cc} u_i & t_i \\ \circ & \circ \end{array} \\ \begin{array}{c} | \\ Z^{d-1} \\ \square \\ s \end{array} \\ Z \end{array} = \begin{array}{c} B \quad Z \\ \circ \quad | \\ \eta_B \quad Z \end{array}$$

In view of the definition of (Q, m_Q, η_Q) , the left hand side of (69) equals

$$(70) \quad \begin{aligned} & \sum_{i=1}^d (-1)^{d-i} (p \circ c_{S(Z), S(Z)^{\otimes(i-1)}} \otimes \text{id}_{S(Z)^{\otimes(d-i)}} \circ v_1 \otimes \cdots \otimes v_1) \\ & \otimes \text{id}_Z \circ \text{id}_Z \otimes s \\ & = (p \circ v_1 \otimes \cdots \otimes v_1) \otimes \text{id}_Z \\ & \circ \left(\sum_{i=1}^d (-1)^{d-i} c_{Z, Z^{\otimes(i-1)}} \otimes \text{id}_{Z^{\otimes(d-i)}} \otimes \text{id}_Z \circ \text{id}_Z \otimes s \right). \end{aligned}$$

Writing $K_i = c_{Z, Z^{\otimes(i-1)}} \otimes \text{id}_{Z^{\otimes(d-i+1)}} \circ \text{id}_Z \otimes s$, where $i \in \{1, \dots, d\}$, one easily verifies

$$\Pi_{d+1}^Z(\sigma_j) \circ K_i = \begin{cases} K_{i-1} & : j = i - 1 \\ K_{i+1} & : j = i \\ -K_i & : \text{otherwise} \end{cases}$$

for all $j \in \{1, \dots, i - 1\}$. This implies that the morphism $Z \rightarrow Z^{\otimes(d+1)}$ in the large brackets of (70) is totally antisymmetric w.r.t. the first d legs, i.e. changes its sign upon multiplication with $\Pi_{d+1}^Z(\sigma_j)$, $j = 1, \dots, d - 1$ from the left. We can thus insert $A_d^Z = s \circ s'$ at the appropriate place and see that (70) equals

$$\begin{aligned} & = (p \circ v_1 \otimes \cdots \otimes v_1) \otimes \text{id}_Z \circ (s \circ s') \otimes \text{id}_Z \\ & \circ \left(\sum_{i=1}^d (-1)^{d-i} c_{Z, Z^{\otimes(i-1)}} \otimes \text{id}_{Z^{\otimes(d-i)}} \otimes \text{id}_Z \circ \text{id}_Z \otimes s \right) \\ & = (p \circ v_1 \otimes \cdots \otimes v_1 \circ s) \otimes \text{id}_Z \\ & \circ \left(\sum_{i=1}^d (-1)^{d-i} s' \otimes \text{id}_Z \circ c_{Z, Z^{\otimes(i-1)}} \otimes \text{id}_{Z^{\otimes(d-i)}} \otimes \text{id}_Z \circ \text{id}_Z \otimes s \right). \end{aligned}$$

Now, $p \circ v_1 \otimes \cdots \otimes v_1 \circ s = p \circ f = \eta_B$. On the other hand, by the total antisymmetry of s we have $s' \circ c_{Z, Z^{\otimes(i-1)}} \otimes \text{id}_{Z^{\otimes(d-i)}} = (-1)^{i-1} s'$ and thus

$$\begin{aligned} & \sum_{i=1}^d (-1)^{d-i} s' \otimes \text{id}_Z \circ c_{Z, Z^{\otimes(i-1)}} \otimes \text{id}_{Z^{\otimes(d-i)}} \otimes \text{id}_Z \circ \text{id}_Z \otimes s \\ & = \sum_{i=1}^d (-1)^{d-i} (-1)^{i-1} s' \otimes \text{id}_Z \circ \text{id}_Z \otimes s \\ & = d(-1)^{d-1} s' \otimes \text{id}_Z \circ \text{id}_Z \otimes s = \text{id}_Z, \end{aligned}$$

where the last equality is provided by Lemma 424. Thus (69) is true, implying $\sum_{i=1}^d q_i \circ p_i = \text{id}_{B \otimes Z}$ and therefore the claimed isomorphism $B \otimes Z \cong d(Z)B$ of B -modules. ■

LEMMA 431. *Let \mathcal{C}, Z and the monoid (Q, m, η) be as in Lemma 428. Then the commutative algebra $\Gamma_Q = \text{Hom}(\mathbf{1}, Q)$ is \mathbb{Z}_+ -graded and has at most countable dimension.*

Proof. By construction of Q we have

$$\Gamma_Q = \text{Hom}(\mathbf{1}, Q) = \lim_n \bigoplus_{i=0}^n \text{Hom}(\mathbf{1}, S_i(Z)) = \bigoplus_{i \geq 0} \text{Hom}(\mathbf{1}, S_i(Z)).$$

Each of the direct summands on the right hand side lives in \mathcal{C} and thus has finite dimension. It follows that Γ_Q has at most countable dimension. That Γ_Q is a \mathbb{Z}_+ -graded algebra is evident from the definition of m_Q in terms of the morphisms $m_{i,j} : S_i(X) \otimes S_j(X) \rightarrow S_{i+j}(X)$ of Lemma 426. ■

THEOREM 432. *Let $Z \in \mathcal{C}$ be such that $\det Z \cong \mathbf{1}$. Then there exists a commutative monoid (B, m_B, η_B) in $\text{Ind } \mathcal{C}$ such that $\dim \text{Hom}_{\text{Ind } \mathcal{C}}(\mathbf{1}, B) = 1$ and there is an isomorphism $B \otimes Z \cong d(Z)B$ of B -modules.*

Proof. Let (Q, m, η) and the ideal $j = \text{im } m_0 : (J, \mu) \rightarrow (Q, m)$ as before. Assume that j is an isomorphism, thus epi. Then m_0 is epi and thus an isomorphism by Lemma 366. In particular, the map $\Gamma_Q \rightarrow \Gamma_Q$ given by $s \mapsto s \bullet (f - \eta)$ is an isomorphism, thus $f - \eta \in \Gamma_Q$ is invertible. This, however, is impossible since Γ_Q is \mathbb{Z}_+ -graded and $f - \eta \in \Gamma_Q$ is not in the degree-zero part. Thus the ideal j is proper. By Lemma 362 there exists a maximal ideal $\tilde{j} : (\tilde{J}, \tilde{\mu}) \rightarrow (Q, m)$ containing $j : (J, \mu) \rightarrow (Q, m)$. If the monoid (B, m_B, η_B) is the quotient of (Q, m, η_Q) by $\tilde{j} : (\tilde{J}, \tilde{\mu}) \rightarrow (Q, m)$, Proposition 430 implies the isomorphism $B \otimes Z \cong d(Z) \cdot B$ of B -modules. By Lemma 364, the quotient module (B, m_B, η_B) has no proper non-zero ideals, thus by Lemma 365, the commutative \mathbb{C} -algebra $\text{End}_B((B, m_B))$ is a field extending k . By Lemma 358, $\text{End}_B((B, m)) \cong \text{Hom}(\mathbf{1}, B) =: \Gamma_B$ as a \mathbb{C} -algebra. By Lemma 371, the unit $\mathbf{1} \in \text{Ind } \mathcal{C}$ is projective, thus Lemma 363 implies that Γ_B is a quotient of Γ_Q , and by Lemma 431 it has at most countable dimension. Now Lemma 433 below applies and gives $\Gamma_B = \mathbb{C}$ and therefore $\dim \text{Hom}(\mathbf{1}, B) = 1$ as desired. ■

LEMMA 433. *Let $K \supset \mathbb{C}$ a field extension of \mathbb{C} . If $[K : \mathbb{C}] \equiv \dim_{\mathbb{C}} K$ is at most countable then $K = \mathbb{C}$.*

Proof. Assume that $x \in K$ is transcendental over \mathbb{C} . We claim that the set $\{\frac{1}{x+a} \mid a \in \mathbb{C}\} \subset K$ is linearly independent over \mathbb{C} : Assume that $\sum_{i=1}^N \frac{b_i}{x+a_i} = 0$, where the a_i are pairwise different and $b_i \in \mathbb{C}$. Multiplying with $\prod_i (x+a_i)$ (which is non-zero in K) we obtain the polynomial equation $\sum_{i=1}^N b_i \prod_{j \neq i} (x+a_j) = 0 =$

$\sum_{k=0}^{N-1} c_k x^k$ for x . Since x is transcendental, we have $c_k = 0$ for all $k = 0, \dots, N-1$. This gives us N linear equations $\sum_{i=1}^N M_{ki} b_i = 0$, $k = 1, \dots, N$, where $M_{ki} = \sum_{\substack{S \subset \{1, \dots, N\} - \{i\} \\ \#S = k-1}} \prod_{s \in S} a_s$. This matrix can be transformed into the matrix $(V_{ki} = a_i^{k-1})$ by elementary row transformations. By Vandermonde's formula, $\det V = \prod_{i < j} (a_j - a_i) \neq 0$, thus the only solution of $M\mathbf{b} = 0$ is $b_1 = \dots = b_N = 0$, proving linear independence. Since \mathbb{C} is uncountable this contradicts the assumption that K has countable dimension over \mathbb{C} . Thus K/\mathbb{C} is algebraic and therefore $K = \mathbb{C}$ since \mathbb{C} is algebraically closed. ■

Finally we have:

Proof of Theorem 411. If \mathcal{C} is an even STC^* with monoidal generator Z , Lemma 423 allows us to assume $\det Z \cong \mathbf{1}$ (replacing Z by $Z \oplus \bar{Z}$). Now Theorem 432 provides a monoid (B, m, η) in $\text{Ind } \mathcal{C}$ satisfying the assumptions of Corollary 415, which gives rise to a symmetric fiber functor $E : \mathcal{C} \rightarrow \text{Vect}_{\mathbb{C}}$. ■

REMARK 434. It seems instructive to point out the main difference of our proof of Theorem 411 w.r.t. the approaches of [Deligne, 1990; Bichon, 1998]. In [Deligne, 1990], a commutative monoid (Q, m, η) for which there is an isomorphism $Q \otimes Z \cong d(Z)Q$ of Q -modules is constructed by a somewhat complicated inductive procedure. The explicit construction of the monoid that we gave is due to [Bichon, 1998]. Deligne proceeds by observing that, for every $X \in \mathcal{C}$, the k -vector space $\text{Hom}(\mathbf{1}, Q \otimes X)$ is a module over the commutative ring $\Gamma_Q := \text{End}_Q((Q, m)) \cong \text{Hom}(\mathbf{1}, Q)$, and the functor $\tilde{E} : X \mapsto \text{Hom}(\mathbf{1}, Q \otimes X)$ is monoidal w.r.t. the tensor product of $\Gamma_Q - \text{Mod}$ (rather than that of $\text{Vect}_{\mathbb{C}}$). Now, a quotienting procedure w.r.t. a maximal ideal J in Γ_Q is used to obtain a tensor functor $E : \mathcal{C} \rightarrow K - \text{Vect}$, where $K = \Gamma_Q/J$ is a field extension of the ground field k . If $\text{Hom}(\mathbf{1}, Q)$ is of at most countable dimension then $[K : k] \leq \aleph_0$, and if k is uncountable and algebraically closed it follows that $K = k$.

Our approach differs in two respects. Less importantly, our insistence on $\det Z \cong \mathbf{1}$ makes the construction of the monoid (Q, m, η) slightly more transparent than in [Bichon, 1998]. More importantly, we perform the quotienting by a maximal ideal inside the category of Q -modules in $\text{Ind } \mathcal{C}$ rather than in the category of Γ_Q -modules, yielding a monoid (Q', m', η') in $\text{Ind } \mathcal{C}$ with $\Gamma_{Q'} = \mathbb{C}$. Besides giving rise to a symmetric fiber functor $E : \mathcal{C} \rightarrow \text{Vect}_{\mathbb{C}}$ in a more direct fashion, this has the added benefit, as we will show in the final subsection, of allowing to recover the group $\text{Nat}_{\otimes} E$ without any reference to the fiber functor and its natural transformations! The ultimate reason for this is that, due to uniqueness of the embedding functor, the monoid (Q', m', η') in $\text{Ind } \mathcal{C}$ is nothing but the monoid $(\pi_l, \tilde{m}, \tilde{\eta})$ in $\text{Rep } G$ that arises from the left regular representation of G , cf. [Mürger and Tuset, 2006].

B.12 Addendum

In the previous subsection we have concluded the proof of the existence of a fiber functor and, by the concrete Tannaka theorem, of the equivalence $\mathcal{C} \simeq \text{Rep}_f(G, k)$, where (G, k) is a compact supergroup. However, we would like to show how the group $\text{Nat}_{\otimes} E$, and in some cases also G , can be read off directly from the monoid (Q, m, η) , bypassing fiber functors, natural transformations etc.

DEFINITION 435. The automorphism group of a monoid (Q, m, η) in a strict tensor category \mathcal{C} is

$$\text{Aut}(Q, m, \eta) = \{g \in \text{Aut } Q \mid g \circ m = m \circ g \otimes g, g \circ \eta = \eta\}.$$

PROPOSITION 436. Let \mathcal{C} be an STC* and (Q, m, η) a monoid in $\text{Ind } \mathcal{C}$ satisfying

- (i) $\dim \text{Hom}_{\text{Ind } \mathcal{C}}(\mathbf{1}, Q) = 1$.
- (ii) For every $X \in \mathcal{C}$, there is $n(X) \in \mathbb{Z}_+$ such that $n(X) \neq 0$ whenever $X \not\cong 0$ and an isomorphism $\alpha_X : (Q \otimes X, m \otimes \text{id}_X) \rightarrow n(X) \cdot (Q, m)$ of Q -modules.

Then the group $\text{Nat}_{\otimes} E$ of monoidal natural automorphisms of the functor constructed in Proposition 413 is canonically isomorphic to the group $\text{Aut}(Q, m, \eta)$.

Proof. Let $g \in \text{Aut}(Q, m, \eta)$. For every $X \in \mathcal{C}$ define $g_X \in \text{End } E(X)$ by

$$g_X \psi = g \otimes \text{id}_X \circ \psi \quad \forall \psi \in E(X) = \text{Hom}(\mathbf{1}, Q \otimes X).$$

From the definition of $(g_X)_{X \in \mathcal{C}}$ and of the functor E it is immediate that $(g_X)_{X \in \mathcal{C}}$ is a natural transformation from E to itself. We must show this natural transformation is monoidal, i.e.

$$\begin{array}{ccc} E(X) \otimes E(Y) & \xrightarrow{d_{X,Y}} & E(X \otimes Y) \\ g_X \otimes g_Y \downarrow & & \downarrow g_{X \otimes Y} \\ E(X) \otimes E(Y) & \xrightarrow{d_{X,Y}} & E(X \otimes Y) \end{array}$$

commutes. To this end consider $\phi \in E(X) = \text{Hom}(\mathbf{1}, Q \otimes X), \psi \in E(Y) = \text{Hom}(\mathbf{1}, Q \otimes Y)$ and $g \in \text{Aut}(Q, m, \eta)$ with $(g_X)_{X \in \mathcal{C}}$ as just defined. Then the image of $\phi \boxtimes \psi \in E(X) \otimes E(Y)$ under $g_{X \otimes Y} \circ d_{X,Y}$ is

$$g \otimes \text{id}_{X \otimes Y} \circ m \otimes \text{id}_{X \otimes Y} \circ \text{id}_Q \otimes \phi \otimes \text{id}_Y \circ \psi,$$

whereas its image under $d_{X,Y} \circ g_X \otimes g_Y$ is

$$m \otimes \text{id}_{X \otimes Y} \circ g \otimes g \otimes \text{id}_{X \otimes Y} \circ \text{id}_Q \otimes \phi \otimes \text{id}_Y \circ \psi.$$

In view of $g \circ m = m \circ g \otimes g$, these two expressions coincide, thus $(g_X) \in \text{Nat}_{\otimes} E$. It is very easy to see that the map $\sigma : \text{Aut}(Q, m, \eta) \rightarrow \text{Nat}_{\otimes} E$ thus obtained is a group homomorphism.

We claim that σ is an isomorphism. Here it is important that we work in $\text{Ind } \mathcal{C}$ rather than any category $\widehat{\mathcal{C}}$, since this implies that Q is an inductive limit of objects in \mathcal{C} . The assumptions (i),(ii) then give $\text{Hom}(X, Q) \cong \text{Hom}(\mathbf{1}, Q \otimes \overline{X}) \cong \mathbb{C}^{n(\overline{X})}$ for all $X \in \mathcal{C}$ and thus (using $n(X) = n(\overline{X}) = \dim E(X)$)

$$(71) \quad Q \cong \varinjlim_{S \subset I} \bigoplus_{i \in S} n(X_i)X_i \quad \text{and} \quad \text{End } Q \cong \prod_{i \in I} \text{End } E(X_i),$$

where S runs through the finite subsets of I . Assume now that $\sigma(g)$ is the identity natural transformation, i.e. $g \otimes \text{id}_X \circ \phi = \phi$ for all $X \in \mathcal{C}$ and $\phi \in \text{Hom}(\mathbf{1}, Q \otimes X)$. Be the existence of conjugates in \mathcal{C} , this is equivalent to $g \circ s = s$ for all $Y \in \mathcal{C}$ and $s \in \text{Hom}(Y, Q)$. Since Q is an inductive limit of objects in \mathcal{C} , this implies $g = \text{id}_Q$.

If now $\alpha \in \text{Nat}_{\otimes} E$, we first observe that α is a natural isomorphism by 396. By the isomorphisms $\text{Nat } E \cong \prod_{i \in I} \text{End } E(X_i)$ (cf. the proof of Proposition 375) and (71), we have a map $\text{Nat}_{\otimes} E \rightarrow \text{Aut } Q$. Reversing the preceding computations shows that every $\alpha \in \text{Nat}_{\otimes} E$ gives rise to an element of $\text{Aut}(Q, m, \eta)$. ■

REMARK 437. This result shows that the group $\text{Nat}_{\otimes} E$ can be recovered directly from the absorbing monoid (Q, m, η) in $\text{Ind } \mathcal{C}$. In general the compact group G as defined in Subsection B.1 is a true subgroup of $\text{Nat}_{\otimes} E$, the latter being the pro-algebraic envelope of G . (In the cases of $G = U(1), SU(2), U(2)$, e.g., that would be $\mathbb{C}^\times, SL(2, \mathbb{C}), GL(2, \mathbb{C})$, respectively.) But if \mathcal{C} is finite (i.e. has finitely many isomorphism classes of simple objects) then $\text{Nat}_{\otimes} E$ is finite and $G = \text{Nat}_{\otimes} E$. Interestingly, even in the case of finite \mathcal{C} , where the monoid (Q, m, η) actually lives in \mathcal{C} , there seems to be no way to recover G without using $\text{Ind } \mathcal{C}$ at an intermediate stage.