

Electrodynamic Measurements, Especially on Diamagnetism

W. Weber

Abstract

English translation of Wilhelm Weber's 1852 paper "Elektrodynamische Maassbestimmungen insbesondere über Diamagnetismus", [Web52a]. This work is the third of Weber's eight major Memoirs on "Elektrodynamische Maassbestimmungen", *Electrodynamic Measurements*.

Posted in March 2020 at www.ifi.unicamp.br/~assis

Contents

1	Electrodiamagnetism and Measurement of the Moment of an Electrodiamagnet	6
2	Electrodiamagnetic Measuring Device	7
3	Experiments and Measurements	13
4	Computation of the Experiments	18
5	The Most Convenient Device to Observe Diamagnetic Polarity	21
6	Diamagnetolectricity and Measurement of Diamagnetic Induced Electric Currents	24
7	Description of the Diamagnetic Inductor	24

	2
8 Experiments	29
9 Computation of the Measurements	39
10 Comparison of the Two Determinations of the Strength of an Electrodiamagnet from its Magnetic and Magnetoelectric Effects	42
11 The Experiments of Faraday	48
12 The Experiments and the Theory of Feilitzsch	51
13 On the Connection Between the Theory of Diamagnetism with the Theory of Magnetism and Electricity	53
14 On the Way How to Examine the Causes of Diamagnetism	53
15 Classification of Internal Causes which Can Give Rise to the Given Effects of an Ideal Distribution	55
16 Dependence of the Ideal Distribution on the Magnetic Separating Force According to the Difference of the Four Above Mentioned Possible Internal Causes	56
17 Internal Cause of Diamagnetism	58
18 Determination of the Electromagnetic Separating Force in a Galvanic Spiral	58
19 Determination of Electrodiamagnetism Using the Electromagnetic Separating Force	61
20 Comparison of the Interaction of Diamagnetic Molecules with the Interaction of Magnetic Molecules	63
21 Distinction of Magnetic and Diamagnetic Materials with the Help of Positive and Negative Values of a Constant	65
22 On the Existence of Magnetic Fluids	68
23 On the Dependence of the Magnetic and Diamagnetic Moment on the Size of the Separating Force	71

24 Connection Between the Existence of a Maximal Value of the Magnetic Moment and the Assumption that the Molecules Are Rotatable	73
25 Experiments to Prove the Existence of a Maximal Value of the Magnetic Moment	75
26 The Law of the Dependence of the Magnetic Moment on the Size of the Separating Force According to the Assumption of Rotatable Molecules and Its Comparison with Experiments	79
27 Application Made to the Comparison in Section 10	83
References	87

By Wilhelm Weber^{1,2,3}

Diamagnetism in the few years since its discovery became the topic of various researches. These not only broadened the field but also led to the discovery and examination of several other new natural phenomena. Therefore, the interest on these researches grew continuously. However, the field of *diamagnetism* still needs a *fundamental law*, in order to become comparable to magnetism, electromagnetism, and magnetoelectricity, to which it is closely related. To obtain such a *fundamental law* seemed since its beginning doable, because Faraday managed to find a very simple and general expression concerning the major facts discovered by him, namely the diamagnetic *repulsion* and the *equatorial position* of diamagnetic materials in the vicinity of a strong magnet. Even if his general expression cannot be considered as a fundamental law, it seems to be closely related to one. Faraday namely deduced these diamagnetic actions from the laws of *variable magnets* (iron magnets), by comparing the actions of diamagnetic materials to the ones of magnetized iron for which North magnetism and South magnetism were interchanged. The relation between diamagnetism and magnetism after that is the *law of diamagnetic polarity* found by Faraday.

To make it clear what *magnetic* or *diamagnetic polarity* means, we explain how this notion is used in this paper. It is well-known that Gauss proved,⁴ that all actions by which a magnet (or a material which contains galvanic currents) effects other materials, can be deduced from two magnetic fluids, which are distributed on *its surface* in a specific manner. Gauss called this distribution *the ideal distribution of magnetic fluids*. Hence we refer in this paper by *magnetic* or *diamagnetic polarity* to the state of a material through which it can effect forces to other materials in such a way that these forces can be explained in terms of *the ideal distribution of magnetic fluids*.

Therefore the law of *diamagnetic polarity* implies, that all actions of a diamagnetic material can be explained in terms of *an ideal distribution of the two magnetic fluids* on its surface. Since the law of the *magnetic polarity* requires the same for magnetic materials, it follows under the assumption that there exists really a *diamagnetic polarity* in this sense,

diamagnetic materials do not distinguish themselves essentially

¹[Web52a].

²Translated by U. Frauenfelder, urs.frauenfelder@math.uni-augsburg.de, and edited by U. Frauenfelder and A. K. T. Assis, www.ifi.unicamp.br/~assis

³The Notes by Wilhelm Eduard Weber are represented by [Note by WEW:]; the Notes by H. Weber, the Editor of Volume 3 of Weber's *Werke*, are represented by [Note by HW:]; while the Notes by A. K. T. Assis are represented by [Note by AKTA:].

⁴[Note by AKTA:] [Gau39], [Gau41a] and [GT14].

from *magnetic* ones in terms of their *actions*, but how they are *generated* and how they *change*.

Namely suppose that before their generation (or transformation) we have an *ideal distribution*, then all the actions are given, independent if it is *magnetism*, *galvanism*, or *diamagnetism* which leads to that *ideal distribution*.

If the law of *diamagnetic polarity* is really universally true, it is not just applicable to the phenomena first discovered by Faraday, namely the interaction of the diamagnetic material with the magnet due to whose influence it became diamagnetic, but to all phenomena a material can effect other materials due to a certain distribution of its magnetic fluids. All these different kinds of phenomena can be classified into *purely magnetic* ones, *electromagnetic* ones, and *magnetolectric* ones. Therefore it is highly interesting to detect the actual occurrence of these *different modes of effects*. If the *second* effect really existed for diamagnetic materials, it would lead to the fundamental experiment of *electrodiamagnetism*. The *third* effect would lead to the fundamental experiment of *diamagnetolectricity* (or the diamagnetic induction of electric currents). On the other hand, if not all these effects occurred, this would imply that the law of *diamagnetic polarity* is not universally valid, so that it would lose its importance and theoretical significance.

Concerning the occurrence of these different modes of effects the results of different researchers do not yet agree with each other. This is easily explained, if one takes into account how weak necessarily the later kinds of effects have to be. Therefore it can easily happen that not all researchers can detect them especially since they do not use exactly the same kind of devices. In particular, Faraday did not succeed in convincing himself of the (inducing) effect of diamagnetic materials, despite the fact that he repeated the corresponding experiments with great diligence and care.

How weak for example the effect of a diamagnetic material on a magnetic compass is, can be easily understood by noting that even the forces of a strong electromagnet also in small distance to a diamagnetic material are very weak, although they are proportional to the large forces of electromagnets. If one considers instead of the interaction of a somehow diamagnetic material with a strong electromagnet the interaction of a diamagnetic material with a weak magnetic compass, one easily understands that from this last interaction in the same distance a force occurs which in the same proportion is smaller although the force in the first interaction was already pretty small.

Under these circumstances where one can see *a priori* that the interactions in question, if they exist, are extremely weak, one needs special arrangements to distinguish them from other small actions in order to prove their existence. It does not suffice to improve and refine the observational equip-

ments, but one has to get a deeper understanding of the size of the effects in question which can be observed so that one can be sure that the *observed* ones really corresponds to the thing one was *looking for*. To say it shortly the observation of such small effects needs *quantitative control* to produce results on a sound basis. But such a quantitative control was missing completely so far. In particular, the question about the existence or non-existence of a *diamagnetic induction of electric currents* which is one of the major issues can only be decided by experiment, if the *size of the current*, which has to be induced diamagnetically, can roughly be estimated. Indeed, only after that one can decide about the means needed to check it.

However, in order to achieve such a *quantitative control* of these considerations one has to discuss more carefully the consideration which led to the conjecture of a *magnetic induction of electric currents*. According to this consideration one assumes that all effects of a diamagnetic material can be explained in terms of a certain distribution of the two magnetic fluids on its surface and that on the other hand a diamagnetic material has all effects of the magnetic fluids distributed in this way. It follows from this that one has to associate to each diamagnetic material a *magnetic moment*. Moreover, each kind of diamagnetic action has to be used in order to determine the size of this magnetic moment so that one can predict precisely or to good approximation all kinds of diamagnetic effects. If this consideration is true it opens the way to infer from known diamagnetic phenomena to unknown ones and predict their size so that each experiment which does not have the required accuracy can be discarded immediately. On the other hand each experiment which has the required accuracy but does not give the result or a completely different one can be used to falsify the whole consideration. A serious decision can only be reached in this way.

During the whole paper I tried to follow this way and I believe that the results obtained here leave no doubt, although it is desirable that in the future the quantitative measurements can be carried out with even higher precision. If I had more funding I could have easily obtained better equipments and gotten more precise results, what is definitely desirable, although the main result does not seem to be in doubt.

1 Electrodiamagnetism and Measurement of the Moment of an Electrodiamagnet

In the same way how one distinguishes *usual* iron magnets, i.e., iron magnets whose magnetism is due to the influence of other magnets, from electromag-

nets, one can distinguish *usual* diamagnets (whose diamagnetism is caused by magnetic influence) from electrodiamagnets. However, between electromagnets and electrodiamagnets there is a huge for the observation important difference. Namely if two equal galvanic currents go around a bar of iron and a bar of bismuth, iron acts by magnetic forces in the distance compared to which the forces of the galvanic current almost vanish, while the diamagnetic forces of bismuth almost vanish compared to the ones of the galvanic current. This is the reason that the *existence of electrodiamagnetism* is difficult to prove. However, this difficulty can be overcome and it even follows from this that the force of an electrodiamagnet is much more suitable to the actual *measurements* than the one of a usual diamagnet. However, for that a special device is needed, in order to get rid of the influence of the galvanic current. Here I *first* want to describe the *device* using that I got the *pure* action of an *electrodiamagnet* so that I could compare the size of its force with the one of an *electromagnet*. *After that* I describe the *results* I obtained in the experiments using that device.

2 Electrodiamagnetic Measuring Device

The goal was to observe the effect of an electrodiamagnet on a magnetic needle one puts in some distance. It was already mentioned before, how small the expected effect of a diamagnetic material on a usual magnetic needle is, especially if this needle is some inches away from the diamagnet. The smaller the expected effect was, the finer methods of observation have to be applied. Therefore a small magnetometer was used, whose needle was 100 millimeters long and carried a mirror in order to be observable according to the method of Gauss using telescope and scale. With this method deflections of the needle of single arc minutes could be measured exactly. The sensitivity of such a needle depends as is well known on the size of the horizontal deflecting force exerted by terrestrial magnetism. If the deflecting force of terrestrial magnetism was not weakened the oscillation period of the needle was 7.687 seconds. To augment the sensitivity the deflecting force was weakened in such a way that the oscillation period increased to 18.45 seconds. This can be achieved in a quite simple way with the help of a strong magnetic bar *SN* of Figure 2, which one puts with reversed poles in direction of the needle *NS* in appropriate distance. With the help of a small displacement of this magnetic bar, the sensitivity of the needle could be regulated as one pleases. However, a too high sensitivity puts the precision of the observation in slight danger. Furthermore it turned out that the above mentioned sensitivity was sufficient. It is worth mentioning that the needle was furnished with a damper

made of copper which had the effect to reduce the oscillation arcs according to the proportion 3:2 or more precisely the *decrementum logarithmicum*⁵ was

$$= 0.17887 .$$

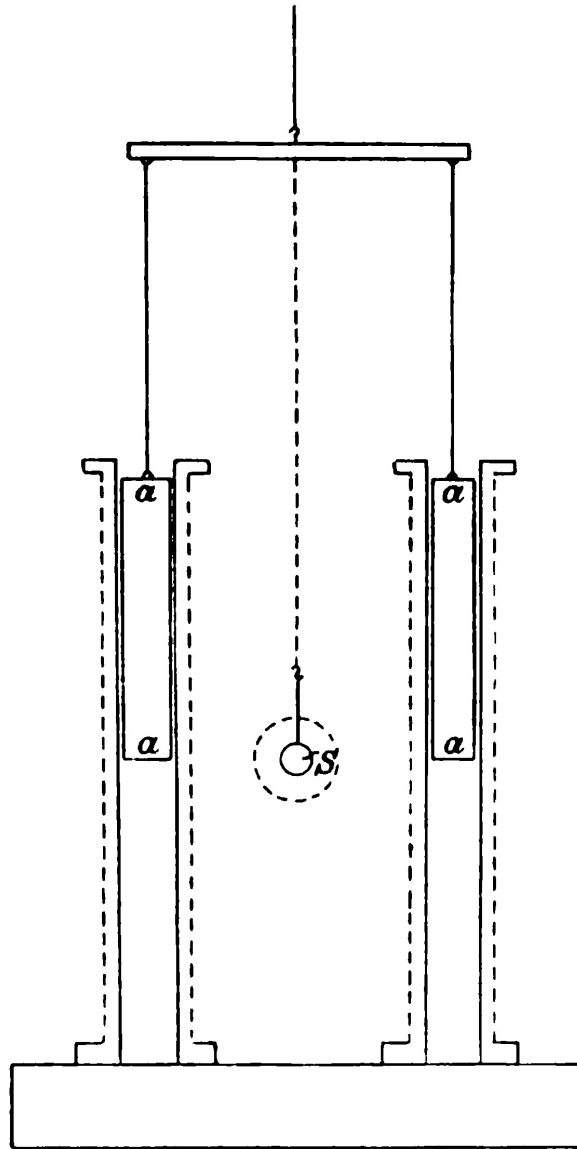

Fig. 1.

After this description of the magnetic measuring device we now proceed with the presentation of the electrodiamagnet and its deployment. The

⁵[Note by AKTA:] That is, the logarithmic decrement.

electromagnet *first* consisted of two equal cylinders made of bismuth whose length was 92 millimeters, whose width was 16 millimeters, and whose combined weight was 343 500 milligrams. They were connected to each other in vertical position at a distance of 100 millimeters, as represented by *aa* in Figure 1. Using a simple crank mechanism they could be lifted and lowered. *Secondly* the electromagnet consisted of spiraling copper wires. Each of these spirals had a length of 190 millimeters, an interior diameter of 17 millimeters and consisted of four layers, each layer containing 146 windings. Like columns, they were vertically mounted on a stand at a distance of 100 millimeters and their wires were connected to each other in such a way that a current which went from one to the other passed through them in opposite direction. Both cylinders of bismuth could be lowered simultaneously into these two spirals and were transformed into electrodiamagnets due to the galvanic current. One North pole turned upwards and one North pole turned downwards. To represent the current six Grove's elements⁶ were used.

⁶[Note by AKTA:] *Grove'schen Bechern* in the original German text.

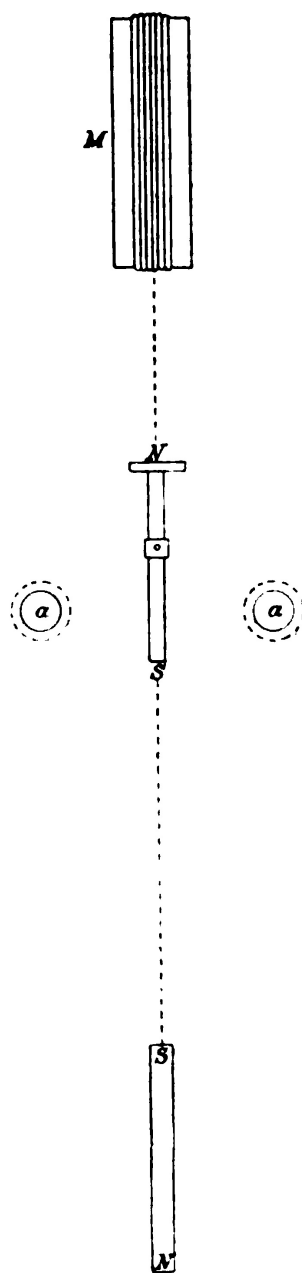

Fig. 2.

These two spirals were now positioned in such a way that a horizontal plane through the needle bisected them. The southern end S of the needle was floating precisely in the middle between the two spirals. In Figure 2 one can see a horizontal section of the position of the needle NS and of the two spirals around aa . The two cylinders consisting of bismuth were either lowered in the spirals to such an extent that their upper end reached the

level of the needle or they were lifted to such an extent that their lower end reached the level of the needle.

The reasons for this deployment are the following. *Firstly* it was important that the galvanic current which went through both spirals did not affect directly the needle despite it was strong and close to the needle and despite the sensitivity of the needle. Due to the symmetric position of the two spirals to the same amount above and below the horizontal plane through the needle, the deflections cancelled. Due to the same distance of the two spirals to the needle and thanks to the opposite direction of their currents, the vertical forces cancelled as well. Otherwise the vertical forces would cause the needle to oscillate. However, since a complete symmetry cannot be achieved in practice a special deployment was needed to compensate the small unavoidable deviations. For this purpose a third wire was used which winded 18 times around a quadrangular frame M and was incorporated into the circuit. This frame had a length of 244 millimeters, a height of 146 millimeters and was erected vertically in the plane of the needle. The same current who went through the two spirals exerted a torque⁷ on the needle by passing through the third wire. By moving the frame closer or farther away, the torque could easily be made bigger or smaller until the intended compensation was reached perfectly.

Secondly the two cylinders consisting of bismuth were put alternatively into the lower and the upper position. In the lower position their upper ends influenced the needle more strongly and in the upper position it was their lower ends which had the stronger influence. It was important to achieve this in such a way that *the strength of the diamagnetism changed without inducing through this movement a current in the conductor bismuth*. Here the advantage of a *diamagnet* compared to a *usual* one became manifest. In fact, a *usual* diamagnetic material whose diamagnetism is due to the vicinity of a magnetic pole changes its diamagnetism after each displacement. Moreover, if the material is a conductor, currents are always induced in it. This is quite different for an electrodiamagnet, where the diamagnetic cylinder of bismuth is enclosed by the galvanic spiral. When this spiral winds uniformly and is so long that the cylinder of bismuth has always some distance to the ends of the spiral, the electromagnetic force of the spiral is almost constant in space according to the known laws of electromagnetism. Therefore one can move the cylinder of bismuth inside the spiral without changing its diamagnetism and without inducing galvanic currents in it. Furthermore the material becomes *uniformly* diamagnetized. In the usual case where the diamagnetism is caused by the vicinity of a magnetic pole, such a thing does not happen. The

⁷[Note by AKTA:] *Drehungsmoment* in the original German text.

reason is that the parts which are closest to the pole become much stronger than the other ones. This fact prevents all measurements.

If in the set-up described there was no direct influence of the current on the needle and no current was induced in the cylinders of bismuth, the deflection of the needle which one observed had to be a pure effect of the *diamagnetic force* of the bars of bismuth. Moreover, this deflection had, according to the law of *diamagnetic polarity*, to be either *positive* or *negative* depending if the bars of bismuth are in *upper* or *lower position* inside the wire spirals. It follows the lucky circumstance for closer examination that one can increase the deflection by *multiplication*, namely by changing the position of the bars of bismuth always in the moment when the needle reaches the end of its oscillation arc. This is repeated so long until due to the effect of the damper the oscillation arc of the needle during each oscillation decreases in the same amount as it increases due to the diamagnetic effect of the bars of bismuth. The corresponding *limit* can be computed with great accuracy by taking into account the sequence of observed oscillation arcs. If the damping is known, it can be used as a *measure of the strength of the electrodiamagnetism* of the bars of bismuth.

If one uses instead of the bars of bismuth an iron cylinder of the same length and repeats the same experiments, one can *compare the strength of an electrodiamagnet with the one of an electromagnet*. It is clear that due to the high sensibility of the apparatus one has to weaken the effect of the electromagnet as far as possible by using a very *thin* iron bar. In the following experiments the iron bar was so thin that its weight was only the 59200th part of the weight of the two bars of bismuth. Even in this case its effect was much stronger than the one of the two bars of bismuth together.

Finally, the *third* major point in these experiments is to determine the *direction* of the deflection for every position of the bars of bismuth and to compare it with the direction the deflection had for the iron bars positioned at the same place. Therefore we kept track in the observations of the position of the bars for every oscillation period. The result was always as the following experiments show, that if the bars of iron and the bars of bismuth had the same position, the deflection of the needle was in *opposite direction*. Hence for *electrodiamagnets* the northern and southern magnetic fluid under the same conditions for the currents have to be thought as *opposite* compared to *electromagnets* as is shown by these experiments. The same phenomenon was known for *usual diamagnets* from different effects.

3 Experiments and Measurements

The experiments and measurements using the above described devices were made by different people in order to remove the uncertainty a single observer faces with such weak effects. Besides me the following gentlemen kindly agreed to repeat the same measurements at different days, namely Professor Listing, Professor Sartorius von Waltershausen, Dr. von Quintus Icilius and Dr. Riemann. For example instead of the data of my own measurements I provide here all datas of the measurements of Professor Listing, which were carried out with extreme care. I just remark, that my own ones as well as all the others closely agree with the ones of Professor Listing.

Göttingen 1851. June 21.

Observer: Professor Listing.

Galvanic Current of six Grove platin-zinc elements.

1. Experiments with Both Bars of Bismuth

No. of the oscillation	position of the bars	position of the needle at the beginning and the end of each oscillation	equilibrium position of the needle	oscillation arc of the needle
		500.0		
1.	above	467.0	487.6	-40.0
2.	below	513.9	488.3	-50.4
3.	above	459.9	488.3	-56.3
4.	below	518.5	489.2	-58.5
5.	above	460.0	487.3	-55.2
6.	below	512.0	489.3	-46.5
7.	above	471.1	484.9	± 29.7
8.	above	489.7	487.3	± 7.0
9.	below	494.2	489.3	-8.9
10.	above	480.9	488.9	-15.6
11.	below	498.9	482.7	-30.0
12.	above	457.0	483.1	-50.4
13.	below	516.0	487.2	-57.8
14.	above	459.3	484.2	-50.9
15.	below	504.4	487.6	± 35.6
16.	below	478.3	483.1	± 12.4
17.	above	476.9	485.6	-14.7
18.	below	504.9	485.7	-36.6
19.	above	459.6	480.6	-42.6
20.	below	499.4	479.6	-39.6
21.	above	460.1	484.1	-46.6
22.	below	513.9	488.2	-51.7
23.	above	464.2	486.8	-45.9
24.	below	506.2	480.0	-50.6
25.	above	446.9	474.1	-55.2
26.	below	498.0	476.4	± 44.5
27.	below	460.0	465.6	± 15.5
28.	above	453.1	462.5	-16.8
29.	below	479.8	464.6	-29.8
30.	above	446.9	467.8	-40.3
31.	below	494.6	471.8	-46.0
32.	above	450.4	471.3	-42.2
33.	below	490.5	468.2	-44.0
34.	above	442.6		

2. Experiments with One Bar of Iron

In order to decrease the effect of the iron to the sensitive needle we only used a simple little bar and made two series of measurements where the little bar was first moved in the first spiral back and forth and then in the second one. The little iron bar had the same length as the little bars of bismuth but its weight was just 5.8 milligram, i.e., it was 59200 times lighter than the two little bars of bismuth together. Nevertheless the effect was so strong that the deflection could only be measured in a simple way *without multiplication*.

<i>First series</i>				
no.	position of the iron bar	elongation of the needle	rest position of the needle	average
1.	below	428.1	300.4	302.0
		215.2		
		362.8		
		261.0		
		301.7		
2.	above	451.2	571.7	571.0
		652.0		
		515.0		
		609.9		
		544.4		
3.	below	435.5	298.2	300.6
		206.7		
		364.7		
		254.6		
		336.9		
4.	above	503.2	560.1	560.7
		598.0		
		536.9		

<i>Second series</i>				
no.	position of the iron bar	elongation of the needle	rest position of the needle	average
1.	above	524.0	563.9 565.8	564.9
		590.5		
		549.3		
2.	below	227.4	323.2 320.1 324.9	322.7
		387.1		
		275.4		
		357.9		
3.	above	450.9	577.4 579.9 570.1	575.8
		661.8		
		525.3		
		600.0		
4.	below	217.8	322.4 318.9 317.6	319.6
		392.2		
		270.0		
		349.4		
5.	above	439.7	559.2 553.0 555.3	555.8
		638.8		
		495.8		
		595.0		

It is worth mentioning that the intensity of the current produced by six Grove's elements was measured with a tangent galvanometer⁸ whose ring

⁸[Note by AKTA:] *Tangentenboussole* in the German original text.

had a diameter of 211 millimeters. The current deflected the compass by an amount of $28^\circ 21'$ from which the intensity of the current (the horizontal part of the terrestrial magnetic force = 1.8) becomes

$$= 105.5 \cdot \frac{1.8}{2\pi} \cdot \text{tang } 28^\circ 21' = 16.31 .$$

4 Computation of the Experiments

In the Table containing the experiments with the two *bars of bismuth* the positions of the needle observed at the beginning and the end of an oscillation are written in the *third* column. From each three of these consecutively observed positions of the needle there are computed in the *fourth* and *fifth* column the corresponding state of rest and the oscillation arc with respect to the damping. A *positive* sign in front of the oscillation arc means that the needle went in case of the *upper position* of the bars of bismuth from smaller to larger scales, respectively in case of the *lower scale* from larger to smaller ones. The opposite holds for the *negative* sign. After the position of the bars of bismuth was changed several times at the end of each oscillation and the oscillation arc almost reached its limit, a break was produced by keeping the positions of the bars of bismuth during two oscillations unchanged. After that they were changed again after every oscillation. The *negative* oscillation arc was transformed in this way into a *positive* one, which however quickly decreased to zero and very soon became *negative* again. In this way one understood the direction of the deflection caused by the bars of bismuth most clearly. — If one counts the oscillation arcs starting from the one which is closest to zero, one can easily reduce the observed values using the well-known *decrementum logarithmicum* to the *limit* and deduce in this way a more accurate mean value of the limit. In the case at hand the *decrementum logarithmicum* is close to $= \log \frac{3}{2}$ and therefore it suffices to divide the value of the oscillation arc by $(1 - (\frac{2}{3})^n)$ or more precisely since the *decrementum logarithmicum* = 0.17887 by $(1 - 0.6624^n)$. Using this procedure one obtains the following reduced values.

No.	observed	reduced	average
1.	-40.0	-63.4	-61.8
2.	-50.4	-66.6	
3.	-56.3	-67.1	
4.	-58.5	-65.5	
5.	-55.2	-59.4	
6.	-46.5	-48.8	
11.	-30.0	-47.5	-59.8
12.	-50.4	-66.6	
13.	-57.8	-68.5	
14.	-50.9	-56.8	
19.	-42.6	-67.5	-56.1
20.	-39.6	-52.3	
21.	-46.6	-55.5	
22.	-51.7	-57.9	
23.	-45.9	-49.4	
24.	-50.6	-53.1	
25.	-55.2	-57.0	
30.	-40.3	-63.9	-55.8
31.	-46.0	-60.2	
32.	-42.2	-50.0	
33.	-44.0	-49.3	

Combining all the observations one obtains the following limit

$$x = -58.4 .$$

The *negative* sign means, that the needle at the *lower position* of the bars of bismuth was driven to a *larger* scale division, while at the *upper position* to a *smaller* one. Moreover, from these experiments carried out according to the *method of multiplication* it follows from the *limit* of the oscillation arcs found to be $= x$ that the *deflection E corresponding to the equilibrium of the needle*

$$E = \frac{x}{2} \cdot \frac{1 - e^{-\lambda}}{1 + e^{-\lambda}} ,$$

according to my rule in the previous paper.⁹ Here $\log e^\lambda$ denotes the logarithmic decrement, i.e., $\log e^\lambda = 0.17887$. From that the *deflection corresponding to the equilibrium of the needle* follows to be

$$E = -5.93 .$$

⁹[Note by AKTA:] [[Web52b](#), p. 440 of Weber's *Werke*].

From the experiments with the *little iron bar* carried out without multiplication the following equilibria of the needle were obtained alternately for the *upper* and *lower* position:

	first series	second series
above	–	564.9
below	302.0	322.7
above	571.0	575.8
below	300.6	319.6
above	560.7	555.8

From that the values of the deflection E follow immediately:

first series	second series
+134.50	+121.10
+135.20	+126.55
+130.05	+128.10
	+118.10

Hence averaging both columns one obtains for the deflection

$$E' = +128.4 .$$

The *positive* sign means, that the needle at the *lower position* of the iron bars was driven to a *smaller* scale division while at the *upper position* to a *larger* one, i.e., *just opposite as in the case of the bars of bismuth*.

Therefore, the *moment of the magnetism* of the little iron bar compared to the moment of the *diamagnetism* of both bars of bismuth behaves as

$$+128.4 : -5.93 ,$$

i.e., the moment of the iron equals 21.7 times the one of bismuth with opposite sign, despite the fact that the mass of the iron was 59200 times smaller. Hence reducing to equal masses the *diamagnetism of bismuth* becomes 1285000 times smaller than the *magnetism of iron*.

From a similar series of experiments carried out by Professor Sartorius von Waltershausen, the *limit*

$$x = -48.2 ,$$

was obtained, from a third one due to Dr. Quintus Icilius

$$x = -47.3 ,$$

from a fourth one of Dr. Riemann

$$x = -45.0 ,$$

and from the one carried out by me

$$x = -55.8 .$$

The average of all these experiments is therefore

$$x = -50.9 ,$$

$$E = -5.17 ,$$

and therefore the *diamagnetism* of bismuth becomes 1470000 times smaller, than the magnetism of iron.

The above experiments allow one to prove the existence of the *electro-diamagnetism* of bismuth. Its derived *size* can only be considered as an approximate one of course. However, such an approximate value is a sufficiently firm base for the following examination of the *diamagnetic induction of galvanic currents*.

5 The Most Convenient Device to Observe Diamagnetic Polarity

The previous experiments prove three things:

- (i) For the representation of diamagnets as for the representation of magnets, the purely magnetic forces can be replaced by *electromagnetic forces* of galvanic currents.
- (ii) In the same way as the *magnetic polarity* of an iron bar magnetized by the same current, the *diamagnetic polarity* of a uniformly diamagnetized bar of bismuth can be observed clearly and for sure with the help of the electromagnetic force of a galvanic spiral in which it is put by observing opposite torques¹⁰ it effects on a magnetic needle depending on the way the bar approaches the needle with one end or with the other.

¹⁰[Note by AKTA:] *Entgegengesetzted Drehungskräfte* in the original German text. It can be translated as “opposite torques” or “opposite rotational forces”.

- (iii) Under the circumstances described the torque of a diamagnetic bar of bismuth on a magnetic needle can be determined and compared to the torques of a magnetized iron bar exerted on the same magnetic needle. It follows that the *direction* of the torque is always *opposite*, while the determination of its *magnitude* leads to a *comparison of the magnetic and diamagnetic moments corresponding to each other*.

All these experiments can be carried out with simple means if they are used appropriately. This is even more remarkable by taking into account that the forces under examination are extremely tiny as mentioned in the introduction. Therefore one could think that the observation of clearly recognizable effects of these small forces requires the application of highly sophisticated devices what is in fact not the case. Indeed, a pile of Grove or Bunsen of six to eight elements and some pound of copper wire of appropriate strength are objects needed for many different experiments. Apart from that one just needs in addition a little magnetic needle endowed with a mirror in order to be observed by a telescope (where a sextant telescope is sufficient) as in the case of a magnetometer.

I invented a device in order to make as easy as possible the implementation of these experiments, which are of crucial importance for the justification of the theory of diamagnetism. In particular, I wanted to minimize the pain to install the apparatus. In particular, I recommend it as the most convenient one for the repetition of the experiments. Its essential feature is that instead of two galvanic spirals which were put into vertical position in the experiments described above in Section 2, so that one of the poles of a *straight* magnetic needle lay symmetrically between them, the new device only requires a *single* spiral.¹¹ This single spiral is installed symmetrically in the middle of two poles of a horseshoe-shaped magnetic needle. In Figure 3 the cross section of this spiral is represented by A , which lies symmetrically between the poles N and S of the horseshoe-shaped bent magnetic needle NBS . This magnetic needle is kept by the clip DE , in whose middle C the thread is attached. Figure 4 and Figure 5 illustrate the instrument in a lateral view.

¹¹[Note by AKTA:] That is, a single solenoid.

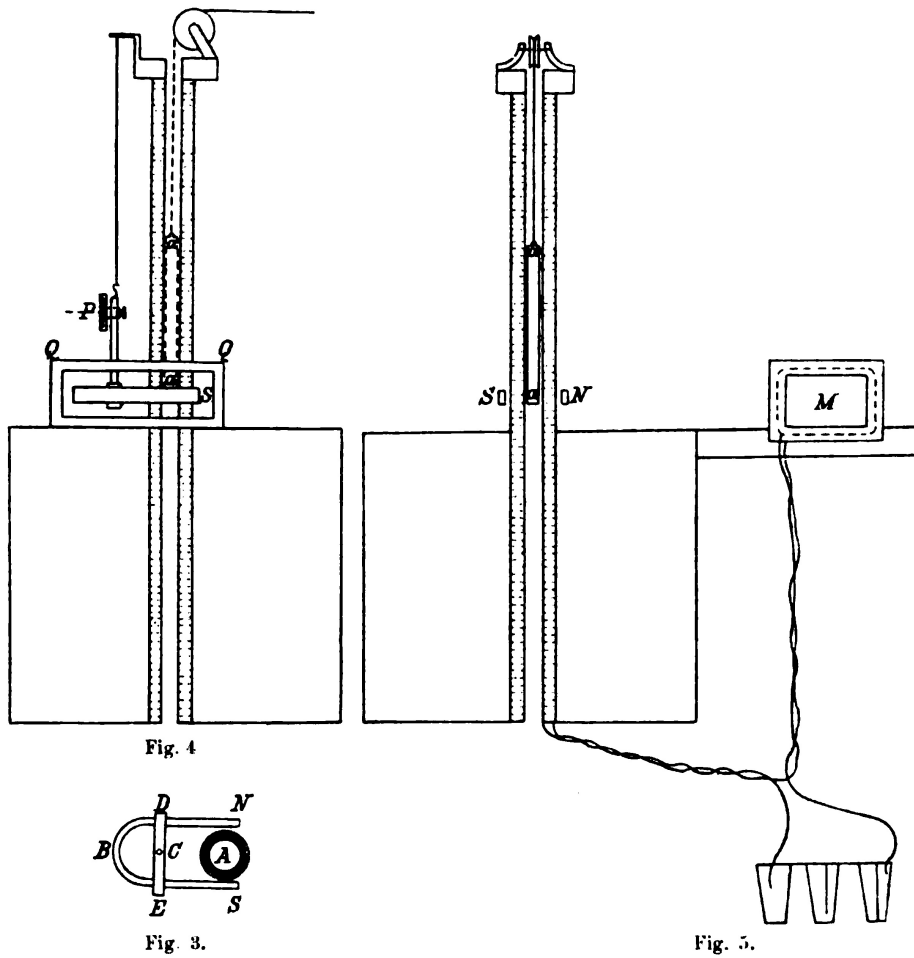

It is advantageous to give the spiral a considerable length, for example from 400 to 500 millimeters, which makes it easier to control the mounting of the needle. In particular, one would like to achieve that the spiral is hovering in the horizontal plane which divides the length of the spiral into two equal halves so that the current going through the spiral does not effect any torque on the needle. In case there is a small torque, it can be easily compensated as explained in Section 2 by a multiplier M consisting of few windings (see Figure 5). To observe the needle it is necessary to supply it with a mirror P as in Figure 4, in which one observes the mirror image of a remote scale. In addition the magnetic needle is encompassed with a damper QQ as in Figure 4. The bar of bismuth aa is suspended vertically in the spiral with a thread (Figure 4 and Figure 5). It can be lifted or lowered so that either, as represented in Figure 4 and Figure 5, its lower end lies between the poles of the magnetic needle or its upper end. The observations can be carried out in the most convenient way if using coils or a simple crank

mechanism the observer himself at the telescope is able to lower or lift the bar of bismuth by lifting or lowering the pedestal. When the current is closed and the magnetic needle at complete rest, if one lifts the bar of bismuth then one observes a small movement of the needle. As soon as the needle attains its largest elongation, the bar of bismuth is lowered again and the magnetic needle moves back with a higher speed. As soon as it attains its largest elongation on this side, the bar of bismuth is lifted again and so on. Between two elongations one notes the position which the bar of bismuth had during the elapsed time. If one interchanges the bar of bismuth with a very thin wire of iron of the same length, one can convince oneself that the deflection of the needle happens in the opposite direction.

6 Diamagnetolectricity and Measurement of Diamagnetic Induced Electric Currents

The experiments about *diamagnetic induction* are obviously more difficult than the previous experiments on *electrodiamagnetism*, because its observation is more subtle. It requires special techniques to set up the experiments in order to actually reach the goal with limited means. The following experiments show how this is possible. Even if the effects obtained with the help of these means are tiny, they show such an agreement that by taking into account the circumstances they are quite remarkable, if the task at hand is to justify the fact of *diamagnetic induction* and to make sure that one is not deceived by external influences. As we will see the effects can be used for *quantitative* determinations of the *strength* of diamagnetic induction which are applicable to such verifications for which a lesser degree of accuracy is sufficient. Only the desire to give these quantitative determinations the necessary precision for some special examinations will make it necessary in the future to apply more sophisticated instruments. I first describe the diamagnetic inductor and then proceed with the experiments carried out with its help.

7 Description of the Diamagnetic Inductor

Here I describe a different magnetic inductor than the one with the help of which I found a weak trace of diamagnetic induction (*Berichte* 1847 and

Poggendorff's *Annalen* 1848, Vol. 73),^{12,13} which however did not have the desirable fineness and accuracy for these experiments. That device was essentially the same which Faraday later used and described in the *Philos. Transact. 1850, P. I.*¹⁴ However, Faraday did not succeed to detect magnetic induction with that device, although he made various different interesting applications with it. The reason for that mixed success probably lies in the finer galvanometric instruments I used. I would have not been able to observe such a diamagnetic induction either, if I had not a galvanometer at my disposal whose needle is observed with mirror and telescope as the magnetometers of Gauss. Nevertheless as well my experiments carried out with that device cannot be considered as sufficient, since the weak effects seem to be combined with other effects from which they hardly can be separated. Moreover, the circumstances do not admit a *quantitative control*. The here described inductor differs from the previous one essentially in the following points.

1. Instead of a usual magnet, an *electromagnet* is used for the induction, whose moment due to the previous examination at least approximately is known. This allows the prediction of the ratio of the inducing effect of the device for a bar of bismuth compared to a bar of iron.
2. The induction is produced by the *mere movement* of the diamagnetic material in a wire spiral at rest. Through this the diamagnetism remains *unchanged* and one avoids the induction of galvanic currents in bismuth as a conductor. Otherwise these galvanic currents can easily be confused with the diamagnetic induced currents.

The Electrodiamagnet Used for the Induction

The *electrodiamagnet* used for the induction consisted of a bar of bismuth in a long wire spiral, *ccc* of Figure 6 A through which a current of eight coal-zinc elements of Bunsen was conducted. The bar of bismuth was 186 millimeters long and weighed 339300 milligrams. The wire spiral consisted of copper wire spanned with wool and additionally insulated with a capping of gutta-percha. The pure copper wire was 2.3 millimeters thick and the wire consisted of eight layers each having 120 windings. The whole spiral was 383 millimeters long and had 23.9 millimeter interior and 70 millimeter exterior diameter.

¹²[Note by HW:] Wilhelm Weber's *Werke*, Vol. III, p. 255.

¹³[Note by AKTA:] [[Web48a](#)], [[Web48b](#), p. 255 of Weber's *Werke*], [[Web52c](#)] and [[Web66](#)].

¹⁴[Note by AKTA:] [[Far50](#)].

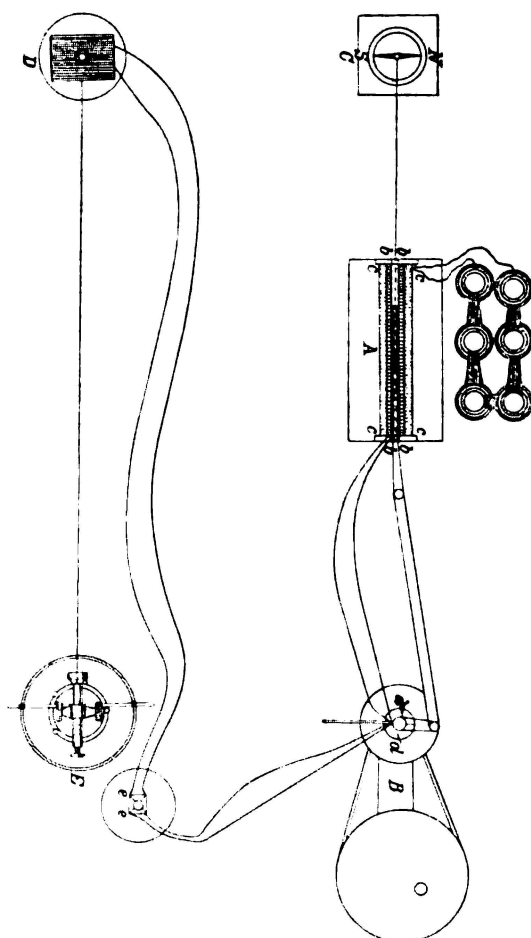

Fig. 6.

The Induction Spiral

The induction spiral *bbbb* of Figure 6 *A* is that spiral in which due to the movement of the *electrodiamagnet* a current is induced. This spiral has to be carefully insulated from the one belonging to the electromagnet through which the current of the galvanic pile flows and has to be connected to the multiplier of the galvanometer in order to observe the induced current. This spiral consisted of a copper wire which was 1 millimeter thick and spanned with silk building three layers each having 294 windings. The length was 383 millimeters, the interior diameter 19, the exterior one 23 millimeters. After it was wrapped with thin gutta-percha for better insulation it was locked tightly in the further tube of the spiral belonging to the electromagnet or more precisely the spiral was wound around it.

The essential point to be noted for this spiral is that it decomposes into two completely symmetric halves. That means that the wire does not uniformly wind in the same direction, rather the spiral decomposes into two halves in which the wire is wound in opposite directions. This is necessary if through the movement of a diamagnetic bar of bismuth or a magnetic iron bar a current has to be induced in this spiral which can be observed with the galvanometer connected to it. Namely if the inducing bar is put in the middle of the spiral and then moved, the induction force in one half of the spiral exerted from its northern end is just opposite to the one exerted from its southern end. The effect of both would cancel out if both halves of the spiral were wound in the same direction. Since they are wound in opposite directions, the induction forces do not cancel each other out but double.

This mechanism necessary for the purpose of induction has another important advantage for the practical implementation. It is clear that the current of the galvanic pile in the spiral of the electrodiamagnet as long as it is *constant* does not exert an inducing force on the induction spiral with respect to that it has a firm, unchanging position. However, due to the slightest *change of its intensity* a current would be induced in the spiral which would be much stronger than the diamagnetic induced current and would disturb the observation of the latter. However, it is obvious that the same mechanism of the induction spiral through which the diamagnetic induction in both halves get doubled as well leads to a cancellation of the induction forces of the current in the galvanic pile so that if the symmetry of both halves is perfect even huge changes of the intensity of the current in the galvanic pile have no influence at all. Moreover, firstly it is very easy to check if this cancellation happens exactly by switching off or commuting the whole current instead of producing small changes. Secondly if it turns out that the cancellation is not perfect, it is easy to make it perfect by winding one end of the induction spiral once or several times around the spiral through which the current of the galvanic pile flows. In this way it is no big problem to free the effects of the diamagnetic induction from all exterior influences.

The Remaining Parts of the Inductor

Concerning the implementation of the remaining parts of the induction device which more or less are left to the taste of the observer I add just the following remarks. In order to move the bar of bismuth in the induction spiral back and forth I connect it with the crank of a wheel, see Figure 6 *B*. Moreover, in order that the induced current when moving the bar of bismuth back has the same direction as when moving the bar of bismuth forward, a *commutator dd* is attached to the wheel, *which turns itself with the wheel*

so that after each half turn of the wheel (in the moment, where the bar of bismuth reaches the initial or endpoint of its orbit) the connection of the ends of the wires of the induction spiral with the ones of the multiplier of the galvanometer are interchanged. Therefore the always same direction in which all induced currents through the multiplier of the galvanometer go would deflect the needle always to the same side. In order to enable the observer to produce as well a deflection of the needle to the other side next to the telescope in Figure 6 *E* a second commutator *ee* is installed, which only from the observer himself is changed. This commutator is referred to as the *auxiliary commutator*. It connects the two wire ends of the multiplier with the two ends of the conductors coming from the *rotating commutator*. By the way one should observe especially the following points. Firstly one tries to intensify the induction more through the acceleration of the turning of the wheel than through the size of the path on which one moves the bar of bismuth back and forth. In the following experiments the bar of bismuth was moved back and forth in a just 58.2 millimeters long path. However, it traversed this path 10.58 times each second. If the path were longer, a part of the bar of bismuth would have approached the end of the spiral through which the current of the galvanic pile went. This would not just change the strength of its diamagnetism but as well induce in it as a conductor a current which produces a secondary induced current in the induction spiral. This has to be avoided if one wants to obtain a pure effect of diamagnetic induction. Secondly the rotating commutator needs special attention, since in it easily a thermomagnetic current is created. Therefore one has to arrange the commutator in such a way that equal metals (brass to brass) rub each other. By this the thermomagnetic currents get just weakened but not avoided completely. The different thermomagnetic currents cancel each other more or less. However, since this cancellation happens in general not completely one has to get rid of their influence by taking it into account. This can be achieved easily if the observer immediately before and after makes the same observations where the rotating commutator is moved without the bar of bismuth. By the way one can arrange the observations as well easily in such a way that the small effects of the thermomagnetic currents alternatively increase and decrease the effects of the diamagnetic induction, which leads to an average value independent of the thermomagnetic current. This is achieved by changing from time to time the direction of the current in the galvanic pile which reverses the diamagnetism in the bar of bismuth. For the galvanometer in Figure 6 *D* I used as in the case of the electrodiamagnetic measuring device a little magnetometer set up by Gauss which was supplied with a very strong multiplier. The length of the needle was reduced to 30 millimeters. The deflecting force of terrestrial magnetism was reduced as be-

fore. The needle also was surrounded by a thick copper ring as a damper. It barely needs to be mentioned that the induction device has to be removed so far from the galvanometer that the current of the galvanic pile used does not influence directly the needle. If there is not enough room to do this, one has to bring the induction device by a special orientation in such a position that its deflecting force on the needle becomes zero or at least very small. Finally, to get a rough estimate of the strength of the current of the galvanic pile itself, a usual compass (Figure 6 *C*) was installed in an appropriate distance of the spiral through which the current went. In this way the deflection of the compass produced by the current could be used to determine the intensity of the current.

8 Experiments

The following experiments as well were not carried out by me alone but Professor Listing, Professor Sartorius von Waltershausen, Dr. Quintus Icilius, and Dr. Riemann participated as in the previous electrodiamagnetic part. As an example I convey here as well the full record of the experiments carried out by Professor Listing with which all the others closely agree.

The inductor was installed in such a way that the vertical plane going through the middle of the galvanometer and through the middle of the wire spiral had an angle of 45 degrees to the magnetic meridian. The axis of that wire spiral was perpendicular to the magnetic meridian. It follows from the laws of electromagnetism confirmed by experience that with this set-up the current does not deflect the needle of the galvanometer. Under these circumstances it was most advantageous to install the compass used to determine the intensity of the current in the direction of the extended axis of the wire spiral through which the current went. This happened in a distance of 708 millimeters from the center on the western side. That current through which the northern end of the compass is deflected *westward* is referred to as *normal current* the one in which the northern part is deflected *eastward* is referred to as *reversed current*. Furthermore, the displacement of the bar of bismuth in the induction device in direction from West to East is called *normal displacement* and in direction from East to West *reversed displacement*. Finally the position the *rotating oscillator* had during the normal displacement of the bar of bismuth is called *normal position* and the one during the reversed displacement is called *reversed position*. A pendulum clock regulated the rotation of the balance wheel and it turned out that the bar of bismuth traversed its path 10.58 times per second. The horizontal distance of the mirror of the magnetic needle from the scale of the galvanometer was 1400

scale divisions. The oscillation period of the galvanometer which for the full deflecting force of terrestrial magnetism was close to 9 seconds was brought to 20.437 seconds through partial cancellation of the force of terrestrial magnetism thanks to the above described method. The logarithmic decrement for the decrease of the oscillation arcs was $= 0.12378$.

The needle of the galvanometer was deflected thanks to diamagnetic induction in the same way when the bar of bismuth moved from West to East as when it moved from East to West, because of the change of the *rotation commutator* in between. This happened without changing the direction of the current in the galvanic pile in the spiral of the electrodiamagnet and the position of the auxiliary commutator. The deflection occurred by moving quickly back and forth in the same way as the one produced by a constant current. However, if the position of the *auxiliary commutator* is changed the deflection of the needle occurs to the opposite side. This implies that in order to get more accurate observations the deflection of the needle can be increased through multiplication by changing the position of the auxiliary commutator always in the moment where the needle attained the end of the oscillation arc, so long, until finally through damping of the needle its oscillation arc is decreased during each oscillation by the same amount as the increase due to the induced current. Therefore between two observed elongations of the needle the by + or – denoted position of the auxiliary commutator was recorded. If the needle at the beginning of the observations was already in swing one started with that position of the auxiliary commutator at which the induced current created a decrease of the present oscillation arc, which than by a continuous change decreased until zero and than started increasing until it attained its limit. When the needle went from smaller to larger scale divisions during the by + designated position of the auxiliary commutator, in the following aggregation of data the + sign was put in front of the oscillation arc, in the opposite case the – sign. The signs of the oscillation arcs turned out to be *opposite* by the *diamagnetic* induction of bismuth compared to the *magnetic* induction of iron. Moreover, the latter oscillation arcs were much bigger, although the bar of iron was much thinner than the bar of bismuth. In fact having the same length the bar of iron weighed 790.86 milligrams where the one of bismuth was 339300 milligrams. Therefore, to measure the effect of the magnetoelectric induction it was not necessary to move the bar of iron back and forth in the same speed as the bar of bismuth. Instead of that a single translation was sufficient during each swing of the needle in the moment when the swinging needle passed its rest position. The two commutators stayed in their normal position and during each two observations of the elongation one always noted the direction into which the bar of iron was displaced. The direction from West to East was

denoted by + and the one from East to West by −, which allowed the comparison to the bar of bismuth. As already mentioned one observed *opposite* effects for the same translations of the bar of iron and the bar of bismuth.

The experiments started by checking 1. if there was an influence of the *thermomagnetic* current and how big it was. For that purpose one started by putting the rotation commutator into motion without moving the bar of bismuth back and forth. The effect was multiplied by changing the auxiliary commutator at each elongation. 2. the *bar of bismuth* was put simultaneously into motion and a bunch of observations were carried out for *normal current*. 3. the same series was done for *reversed current*. 4. the same series again for *normal current*. 5. for *reversed current* and 6. finally again for *normal current*. After that 7. it was checked again if there was an influence of the *thermomagnetic* current and 8. the bar of bismuth was exchanged with the *iron bar* and the induction effect of the latter was measured.

Göttingen 1851. July 13.

Observer: Professor Listing.

Galvanic Current of eight Bunsen coal-zinc elements.

1. Thermomagnetic current.				
no. of the oscillation	position of the auxiliary commutator	position of the needle at the beginning and end of each oscillation	rest position of the needle	oscillation arc of the needle
1.	+	497.0		
2.	−	496.2	496.45	−0.5
3.	+	496.4	496.35	−0.1
4.	−	496.4	496.30	+0.2
5.	+	496.0	496.15	+0.3
		496.2		

According to this Table basically no influence of the thermomagnetic current was there.

2. Induction of the bar of bismuth for <i>normal current</i> .					
no. of the oscillation	position of the auxiliary commutator	position of the needle at the beginning and end of each oscillation	rest position of the needle	oscillation arc of the needle	deflection of the compass
1.	—	475.3			
2.	+	472.8	474.65	+ 3.70	32° 10'
3.	—	477.7	475.00	+ 5.40	westward
4.	+	471.8	475.20	+ 6.80	
5.	—	479.5	475.32	+ 8.35	
6.	+	470.5	475.33	+ 9.65	
7.	—	480.8	475.52	+10.55	
8.	+	470.0	475.70	+11.40	
9.	—	482.0	475.87	+12.25	
10.	+	469.5	475.85	+12.70	
11.	—	482.4	475.90	+13.00	
		469.3			

3. for <i>reversed current</i> .					
no. of the oscillation	position of the auxiliary commutator	position of the needle at the beginning and end of each oscillation	rest position of the needle	oscillation arc of the needle	deflection of the compass
1.	+	503.5			
2.	-	515.9	511.15	+ 9.50	31° 50'
3.	+	509.3	511.13	+ 3.65	eastward
4.	-	510.0	510.62	-1.25	
5.	+	513.2	510.82	-4.75	
6.	-	506.9	510.58	-7.35	
7.	+	515.3	510.85	-8.90	
8.	-	505.9	510.70	-9.60	
9.	+	515.7	510.72	-9.95	
10.	-	505.6	510.53	-9.85	
		515.2			

no. of the oscillation	4. for <i>normal current</i> .				
	position of the auxiliary commutator	position of the needle at the beginning and end of each oscillation	rest position of the needle	oscillation arc of the needle	deflection of the compass
1.	+	480.5			
2.	-	471.0	474.57	-7.15	31° 48'
3.	+	475.8	474.40	-2.80	westward
4.	-	475.0	474.58	+0.85	
5.	+	472.5	474.40	+3.80	
6.	-	477.6	474.47	+6.25	
7.	+	470.2	474.23	+8.05	
8.	-	478.9	474.27	+9.25	
9.	+	469.1	474.10	+10.00	
10.	-	479.3	473.93	+10.75	
11.	+	468.0	473.65	+11.30	
12.	-	479.3	473.65	+11.30	
		468.0			

5. for <i>reversed current</i> .					
no. of the oscillation	position of the auxiliary commutator	position of the needle at the beginning and end of each oscillation	rest position of the needle	oscillation arc of the needle	deflection of the compass
1.	+	501.5			
2.	-	515.0	509.93	+10.15	32° 13'
3.	+	508.2	510.35	+ 4.30	eastward
4.	-	510.0	510.02	-0.05	
5.	+	511.9	510.20	-3.40	
6.	-	507.0	509.80	-5.60	
7.	+	513.3	509.68	-7.25	
8.	-	505.1	509.42	-8.65	
9.	+	514.2	509.38	-9.65	
10.	-	504.0	509.05	-10.10	
11.	+	514.0	508.72	-10.55	
12.	-	502.9	508.40	-11.00	
13.	+	513.8	508.15	-11.30	
14.	-	502.1	507.83	-11.45	
15.	+	513.3	567.67	-11.25	
		502.0			

no. of the oscillation	6. for <i>normal current</i> .				
	position of the auxiliary commutator	position of the needle at the beginning and end of each oscillation	rest position of the needle	oscillation arc of the needle	deflection of the compass
1.	+	486.0			
2.	-	461.0	471.20	-20.40	31° 39'
3.	+	476.8	470.60	-12.40	westward
4.	-	467.8	470.87	-6.15	
5.	+	471.1	470.48	-1.25	
6.	-	471.9	470.52	+ 2.75	
7.	+	467.2	470.08	+ 5.75	
8.	-	474.0	470.45	+ 7.10	
9.	+	466.6	470.25	+ 7.30	
10.	-	473.8	469.92	+ 7.75	
11.	+	465.5	469.83	+ 8.90	
12.	-	475.0	470.02	+ 9.70	
13.	+	465.1	470.13	+10.05	
14.	-	575.3	470.17	+10.25	
15.	+	465.0	470.08	+10.15	
16.	-	475.0	469.95	+10.10	
		464.8			

7. for <i>thermomagnetic current</i> .					
no. of the oscillation	position of the auxiliary commutator	position of the needle at the beginning and end of each oscillation	rest position of the needle	oscillation arc of the needle	deflection of the compass
1.	+	486.1			
2.	-	486.5	486.30	+ 0.40	
3.	+	486.1	486.22	+ 0.25	
4.	-	486.2	486.25	-0.10	
5.	+	486.5	486.35	-0.30	
6.	-	486.2	486.20	0.00	
7.	+	485.9	486.25	+ 0.70	
8.	-	487.0	486.48	+ 1.05	
9.	+	486.0	486.72	+ 1.45	
10.	-	487.9	487.05	+ 1.70	
11.	+	486.4	487.35	+ 1.90	
		488.7			

8. induction of the iron bar for <i>normal current</i> .					
no. of the oscillation	position of the auxiliary commutator	position of the needle at the beginning and end of each oscillation	rest position of the needle	oscillation arc of the needle	deflection of the compass
1.	+	461.0			
2.	-	457.2	464.85	-15.30	31° 48'
3.	+	484.0	467.17	-33.65	westward
4.	-	443.5	466.30	-45.60	
5.	+	494.2	466.73	-54.95	
6.	-	435.0	466.10	-62.20	
7.	+	500.2	466.47	-67.45	
8.	-	430.5	466.25	-71.50	
9.	+	503.8	466.55	-74.50	
10.	-	428.1	466.55	-76.90	
11.	+	506.2	466.90	-78.60	
12.	-	427.1	467.05	-79.90	
13.	+	507.8	467.38	-80.85	
14.	-	426.8	467.35	-81.10	
15.	+	508.0	467.35	-81.30	
16.	-	426.6	467.35	-81.50	
17.	+	508.2	467.33	-81.75	
		426.3			

9 Computation of the Measurements

If one starts counting the oscillation arcs starting from the one closest to zero, the ones coming closest to the limit can be reduced to the *limit* by dividing the n 'th oscillation arc by $(1 - 0.752^n)$ in view of the well-known logarithmic decrement of the decrease of oscillation arcs = 0.12378. Hence the following reduced values are obtained for the experiments carried out for bismuth:

	oscillation arc	observed	reduced	average
2.	8.	+11.40	+13.20	+13.60
	9.	+12.25	+13.65	
	10.	+12.70	+13.75	
	11.	+13.00	+13.80	
3.	8.	-9.60	-14.12	-13.08
	9.	-9.95	-13.10	
	10.	-9.85	-12.02	
4.	9.	+10.00	+13.17	+13.06
	10.	+10.75	+13.12	
	11.	+11.30	+13.08	
	12.	+11.30	+12.88	
5.	10.	-10.10	-12.33	-12.16
	11.	-10.55	-12.21	
	12.	-11.00	-12.25	
	13.	-11.30	-12.24	
	14.	-11.45	-12.15	
	15.	-11.25	-11.76	
6.	11.	+8.90	+10.86	+10.95
	12.	+9.70	+11.23	
	13.	+10.05	+11.20	
	14.	+10.25	+11.10	
	15.	+10.15	+10.77	
	16.	+10.10	+10.56	

If one denotes the small influence by x , which the *thermomagnetic* current had on the result of these measurements, one obtains from the values above the *limit* corresponding to the diamagnetic induction alone reduced to *normal current*:

from 2.	+13.60 + x	+13.34
from 3.	+13.08 - x	+13.07
from 4.	+13.06 + x	+12.61
from 5.	+12.16 - x	+11.555
from 6.	+10.95 + x	

Hence on average

$$= +12.644 .$$

From this *limit* of the oscillation arcs found according to the method of multiplication *for uniform distribution* of the induction pulses on the whole swinging period of the needle, it is now easy to derive the limit value, which would have been obtained by the same method of multiplication if all induction pulses instead of being distributed on the whole oscillation period were concentrated at the *moment*, where the needle passed its rest position. In this way the result obtained for *bismuth* can be compared to the one obtained for *iron*. Namely, by using the well-known logarithmic decrement of the decrease of swinging arcs $0.12378 = \lambda \log e$, where e denotes the unit of the natural logarithm, one finds from the above limit the desired one by multiplication with

$$\frac{\sqrt{\pi^2 + \lambda^2}}{1 + e^{-\lambda}} \cdot e^{-\frac{\lambda}{\pi} \arctan \frac{\pi}{\lambda}} = 1.574235 .$$

Hence the desired limit is

$$+1.574235 \cdot 12.644 = +19.905.^{15}$$

¹⁵[Note by WEW:] If there are many induction pulses distributed uniformly on the whole oscillation period, they act as a constant current on the needle. In this case the rule mentioned on pp. 440 and 487, [[Web52b, p. 440 of Weber's *Werke*] and [Web52a, p. 487 of Weber's *Werke*] which is equivalent of page 19 of this translation], can be applied to the *limit* x found according to the method of multiplication. According to this rule one has $x = 2E \cdot (1 + e^{-\lambda}) / (1 - e^{-\lambda})$, where E is the deflection corresponding to the equilibrium of the needle in case of a constant current and $\lambda \log e$ denotes the logarithmic decrement of the decrease of oscillation arcs. At this equilibrium position of the needle the deflecting force equals the directive force of the needle, which is given by $\pi^2 / T^2 \cdot E$, where T is the oscillation period without the influence of damping. It τ denotes the actual oscillation period taking damping into account, then the velocity the needle obtains is $= \pi^2 / T^2 \cdot E \tau$. This happens under the assumption that the current force evenly distributed on the whole oscillation period acts concentrated at one moment. From this velocity one can compute

The reduction to the *limit* of the experiments carried out with *iron* leads to the following results:

oscillation arc	observed	reduced	average
8.	-71.50	-84.98	
9.	-74.50	-84.60	
10.	-76.90	-84.47	
11.	-78.60	-84.28	
12.	-79.90	-84.16	
13.	-80.85	-84.04	-83.876
14.	-81.10	-83.50	
15.	-81.30	-83.10	
16.	-81.50	-82.85	
17.	-81.75	-82.78	

From this one obtains for the ratio of the two limits corresponding to the *bar of bismuth* and the *bar of iron*

$$+19.905 : -83.876 .$$

Similar experimental series were carried out in the same way by myself, Dr. von Quintus Icilius and Dr. Riemann, where the following ratios were found

$$+18.158 : -83.82 ,$$

$$+15.357 : -82.80 ,$$

$$+14.890 : -83.45 .$$

Averaging all series one obtains the ratio

$$+16.956 : -83.49 .$$

the *limit* of the oscillation arcs, which one approximates according to the method of multiplication in case that the concentrated force always acts on the needle when it passes its rest position. In fact, if one denotes the limit by y , then according to the rule given in the previous article on p. 440, [[Web52b, p. 440 of Weber's *Werke*]], by plugging in the value $= \pi^2/T^2 \cdot E\tau$ for the velocity one obtains

$$\frac{\pi^2}{T^2} \cdot E\tau = \frac{y}{2} \cdot \frac{\pi}{T} (1 - e^{-\lambda}) e^{\frac{\lambda}{\pi} \arctan \frac{\pi}{\lambda}} .$$

Comparing the value of y with the above given value of x leads to the proportion

$$y : x = \frac{\pi\tau}{T} e^{-\frac{\lambda}{\pi} \arctan \frac{\pi}{\lambda}} : (1 + e^{-\lambda}) ,$$

where according to the theory of *damping* the quotient τ/T can be replaced by $\sqrt{1 + \lambda^2/\pi^2}$.

Now the intensity of the currents induced from the *bar of bismuth* and the *bar of iron* is directly proportional to these limits und inversely proportional to the *number* of induction pulses during an oscillation, i.e., the number $10.58 \cdot 20.437 = 216.2$ for the *bar of bismuth* and 1 for the *bar of iron*. Hence the electric currents induced from the *diamagnetic bar of bismuth* are according to their direction *opposite* to the ones induced from the *magnetic bar of iron* and the ratio of their intensities is

$$16.956 : 83.49 \cdot 216.2 = 1 : 1064.5 ,$$

despite the fact that the bar of bismuth weighed 339300 milligrams where the bar of iron just weighed 790.86 milligrams. From that one computes that if the bar of bismuth had the same small weight as the bar of iron, the strength of the *diamagnetically* induced current would have been 456700 times less than that from the bar of iron *magnetically* induced current.

10 Comparison of the Two Determinations of the Strength of an Electrodiagnet from its Magnetic and Magnetolectric Effects

After we considered in the previous two Sections the *magnetic* and *magnetolectric* action of an *electrodiagnet* individually, we finally compare *quantitatively* the two kinds of action. It could seem that this comparison can be carried out quite easily by just first expressing the observed *magnetic* action of an electrodiagnet in terms of the as well observed *magnetic* action of the electromagnet. Then one expresses the observed *magnetolectric* action of an electrodiagnet in terms of the as well observed *magnetolectric* action of the electromagnet. This was already done above and led to the following results

1. $\frac{\text{magnetic action of the electrodiagnet}}{\text{magnetic action of the electromagnet}} = \frac{1470000}{1}$
2. $\frac{\text{magnetolectric action of the electrodiagnet}}{\text{magnetolectric action of the electromagnet}} = \frac{1}{456700} .$

This simple comparison would only be correct if first *the same electrodiagnet* used for the representation of the magnetic effects would have been used as well for the representation of the magnetolectric effects and secondly *the same electromagnet* would have been applied for the representation of both kinds of effects. Finally it would be necessary that the electrodiagnet as

well as the electromagnet acted from a larger *distance* compared to its own size and the one of the material acted on. However, these conditions were not met in the experiments described above and it was impossible to meet them since the representation of the magnetoelectric effects requires the application of quite different devices than the magnetic ones which forced us to make the distances of the materials acting on each other as small as possible.

However if one uses, as was actually the case, *different electrodiamagnets* and *different electromagnets* for the representation of the magnetic and magnetoelectric effects no equality in the mentioned ratios is expected even if they are acting from larger distances. The disparity, namely, that one ratio was about three times larger than the other one, would have been even much larger unless already for the determination of these ratios one took account of the difference of the *masses* of bismuth and iron used for the different electrodiamagnets and electromagnets. By taking into account the inequality of the masses, the coarsest occurring difference was balanced. It is interesting to remark that by taking this into account the above mentioned ratios actually got so close to each other that they can be considered as *quantities of the same order*.

The task at hand is now to detect and determine the other differences which after the difference in mass have the largest influence in order to check how the above ratios change and if they get *closer* to equality.

The reason why this examination is important is that if the used electrodiamagnets and electromagnets were not different at all and acted from a larger distance, the two ratios would have been *quite the same* according to *the laws of diamagnetic polarity discussed in the Introduction*. Since this equality cannot be directly checked in practice, it is important to check at least if one *approximates* this equality the more one takes into account the difference of the electrodiamagnets and electromagnets and the influence the small distance they are acting from has on the *ratio* of their actions. In this way one achieves the same *by approximation* as if one were able to check the claimed equality directly.

The following survey and discussion of all possible differences in question serves this purpose.

In view of the small distance the observed effects refer to, first the *ideal distribution of the magnetic fluids* on the surface of the bar of bismuth compared to the one of the bar of iron should be known more closely. Since this is not the case, it is obvious that such a comparison even if the exactness of the observations were perfect only gives a rough estimate, because the actions effected at small distances have to be put proportional to the *moments*, what strictly speaking is only the case for actions acting at larger distances.

Secondly for the above experiments *two different iron bars* were used, one

had a weight of just 5.8 milligrams where the other one was 790.86 milligrams. We cannot assume that the iron of both little bars behaves in magnetic respect quite the same. Therefore the magnetism of both little bars subject to the same galvanic current was compared and indeed for small intensity of this current the ratio of the magnetic moments differed considerably from the ratio of their masses. However, for increasing intensity of the current, this disparity disappeared and the magnetism of both little bars turned out soon to be almost exactly proportional to their masses. It follows that for our experiments where even more intense currents were used, a reduction due to the heterogeneity of iron was not necessary.

Thirdly in the above experiments *different bars of bismuth* were used, namely two smaller ones for the observation of the magnetic effects and a larger one for the magnetoelectric effects. It cannot be supposed that they behave completely the same in diamagnetic respect. Therefore the latter one was divided into two halves which compared to the former two ones almost coincided in terms of length and thickness. Then with both pairs alternately some experiments to compare diamagnetism were carried out from which a not quite insignificant difference turned out. The effect of the first pair compared to the second one was like 1266 : 1000. Hence if from the induction effects of the larger bar according to the two previous Sections the diamagnetic moment of bismuth compared to the magnetic moment of iron turns out to be = 1/456700, then one obtained for bismuth of the other bar = 1/360740, which does not decrease the difference of this ratio from the one deduced from magnetic actions but even increases it.

Fourthly one should consider the *difference of the electromagnetic separating force*¹⁶ of the two devices used. This difference can be deduced with sufficient exactness from the designations of these devices and it turned out that the electromagnetic separating force of the inductor was 4.8 times larger than the one of the electrodiamagnetic measuring device.¹⁷ At the same time

¹⁶[Note by AKTA:] *Elektromagnetischen Scheidungskraft* in the original German text.

¹⁷[Note by WEW:] The wire spiral of the electrodiamagnetic measuring device according to Section 2 had four layers each consisting of 146 turns and was 190 millimeters long. Its interior diameter was 17 its exterior one 26 millimeters and the intensity of the current was according to Section 3 = 16.31. It follows from this that the electromagnetic separating force in its middle is quite close

$$= \frac{4 \cdot 146 \cdot 2\pi \cdot 16.31}{\frac{1}{2} \cdot 190} = 629.9 .$$

On the other hand the wire spiral of the inductor according to Section 7 had eight layers each consisting of 120 turns and was 383 millimeters long. Its interior diameter was 23.9 its exterior one 70 millimeters and the deflection of a compass laying 708 millimeters to the West was according to the experiments in Section 7 around 32° where one has to put

it follows that in both devices the electromagnetic separating force had such a *strength* that according to the interesting experiments of Müller¹⁸ the magnetic moment of the *little iron bar* could not differ considerably from its maximal value,¹⁹ so that the 4.8 times larger separating force of the inductor did

the intensity of the horizontal part of terrestrial magnetism = 1.8. From this one can first compute the intensity of the current i and the result is quite close to

$$i = \frac{383}{S} \cdot \frac{1.8 \cdot \tan 32^\circ}{\frac{1}{(708 - \frac{1}{2} \cdot 383)^2} - \frac{1}{(708 + \frac{1}{2} \cdot 383)^2}},$$

where S denotes the area enclosed by the spiral which was found = 1793200 square millimeters, hence $i = 95.6$. The separating force of the spiral in question follows from this very closely = $\frac{8 \cdot 120 \cdot 2\pi \cdot 95.6}{\frac{1}{2} \cdot 383} = 3012$. However 3012 : 629.9 equals in very good approximation 4.8 : 1.

¹⁸[Note by AKTA:] [Mül51b] and [Mül51a].

¹⁹[Note by WEW:] A soft iron bar attains a weaker and a stronger magnetism off and on depending on the size of the magnetic or electromagnetic separating force acting on it. Professor Joh. Müller in Freiburg published an interesting examination of the dependence of the magnetism of such iron bars on the strength of the separating forces acting on them in “Berichte über die neuesten Fortschritte der Physik”, Braunschweig 1850, p. 494 et seq., [Mül51a]. An interesting point of this publication is that the magnetism of iron bars has been determined for different, even very large, separating forces. From that the remarkable result followed that the magnetism of the iron bar is not at all always proportional to the separating force acting on the iron, but that it approaches a *limit* for increasing separating forces. Müller summarized the results he measured with an electromagnetic spiral in the following formula

$$s = 0.016 \cdot d^{\frac{3}{2}} \cdot \tan \frac{m}{0.00108 \cdot d^2},$$

where, if i denotes the intensity of the current of the electromagnetic spiral in terms of absolute measure (according to page 252 *ibid*)

$$i = 66.813 \cdot s,$$

and (according to p. 511) if M denotes the magnetism of the iron bar in the electromagnetic spiral according to absolute measure, then

$$M = 5426021 \cdot m.$$

The iron bars used by Müller were 330 millimeters long (according to p. 502) and laid in a wire spiral which was 300 millimeters long protruding on both sides 15 millimeters. d denotes the thickness of the iron bar. The wire spiral consisted of five layers each having 76 turns. Its interior diameter was 49 millimeters and the thickness of the wire was 2.8 millimeters. Consequently, the strength of the *separating force* the current of one layer of turns whose radius = r exerts on a point in the iron bar laying at a distance = a from the spiral is given by the following expression

$$\frac{2 \cdot 76}{300} \pi r^2 i \int_{a-150}^{a+150} \frac{dx}{(r^2 + x^2)^{\frac{3}{2}}} = \frac{152}{300} \pi i \left\{ \frac{a+150}{\sqrt{(a+150)^2 + r^2}} - \frac{a-150}{\sqrt{(a-150)^2 + r^2}} \right\}.$$

This implies that on average for the whole iron bar the strength of the force is given by

$$\begin{aligned} & \frac{152 \cdot \pi i}{300 \cdot 330} \int_{-165}^{+165} \left[\frac{a + 150}{\sqrt{(a + 150)^2 + r^2}} - \frac{a - 150}{\sqrt{(a - 150)^2 + r^2}} \right] da \\ &= \frac{304 \cdot \pi i}{99000} \left\{ \sqrt{315^2 + r^2} - \sqrt{15^2 + r^2} \right\}. \end{aligned}$$

Finally for all five layers

$$\frac{304 \cdot \pi i}{99000} \cdot \frac{5}{14} \int_{24.5}^{38.5} \left[\sqrt{315^2 + r^2} - \sqrt{15^2 + r^2} \right] dr = 13.562 \cdot i.$$

This force differs from the *terrestrial magnetic* force only by its strength and can therefore be determined according to the same *absolute measure*, what also happened here. We denote the strength of this force by X , so that

$$X = 13.562i.$$

Plugging these values into Müller's equation one obtains

$$X = 14.498 \cdot d^{\frac{3}{2}} \cdot \tan \frac{M}{5860 \cdot d^2}.$$

This formula is just valid for iron bars of length 330 millimeters. To apply it to bars with a different length the arc $M/(5860 \cdot d^2)$ has to be multiplied by 330 and divided by the length ℓ of the bar, hence

$$X = 14.498 \cdot d^{\frac{3}{2}} \cdot \tan \frac{M}{17.76 \cdot d^2 \ell}.$$

However, Müller himself remarked that the influence of the length taken into account in this way does not completely coincide with experience and has to be checked in more detail. If one applies this rule deduced from the experiments by Müller, to determine the magnetism of the two little bars of iron, which were in the above described spirals of the *electrodiamagnetic measuring device* and the *induction apparatus*, one gets for the *first* little bar $\ell = 92$ and in addition for its absolute weight = 5.8 milligram and its specific weight = 7.78, from which for its thickness $d = 0.1016$. The value of X for this little bar was determined in the previous Note $X = 629.9$. Therefore one obtains for this little bar

$$\frac{M}{d^2 \ell} = 17.75 \text{arc tang } 89^\circ 57' 23'' = 27.886.$$

For the *second* little bar one has $\ell' = 186$. In addition its absolute weight = 790.86 milligrams and its specific weight = 7.78, so that one finds for its thickness $d' = 0.1016$. The value of X' for this little bar is determined in the previous Note $X' = 3012$. One obtains

$$\frac{M'}{d'^2 \ell'} = 17.76 \text{arc tang } 89^\circ 47' 23'' = 27.834.$$

Noting that $d^2 \ell$ and $d'^2 \ell'$ are proportional to the masses of the two little iron bars, one obtains an almost equal ratio between magnetism and mass of the two little bars, although on the second little bar a 4.8 times larger separating force was acting. A more thorough treatment one finds in Sections 24 until 26 where as well the doubts expressed by Buff and Zamminer against the experiments by Müller are discussed.

not induce a stronger magnetism in the little iron bar than it obtained from the ordinary force. A different behaviour show the *bars of bismuth* whose diamagnetic moment has to be assumed even for the largest representable separating forces as proportionally increasing.²⁰ Hence if one reduces the result obtained from the induction effects to a 4.8 times weaker separating force in order to make it comparable to the results obtained from the magnetic action, the diamagnetic moment of bismuth has to be assumed to be 4.8 times smaller while the magnetic moment of iron remains unchanged. One then obtains for the former moment compared to the latter one instead of $1/360740$ merely $1/4.8 \cdot 360740 = 1/1731560$.

This result deduced from the *magnetolectric* action can now be compared directly to the one found in Section 4 according to which the diamagnetic moment of bismuth compared to the magnetic moment of iron was obtained to be $= 1/1470000$.

The difference of the two considered ratios which before was 200 percent is reduced to 17 until 18 percent by taking into account the mentioned difference. This approximation of equality has to seem even more satisfactory since the comparison is only rough due to the fact that the mentioned reason of that difference could not be considered. One should also observe that the last mentioned far most influential reason of this difference is capable of a closer consideration, if instead on the above quoted experiments by Müller the analysis is based on the more precise results described in Section 24 until Section 26. By doing that the ratio $1/1470000$ is reduced to $1/1593000$ as explained in Section 27 so that only a difference of about 8 percent remains compared to the other ratios.

²⁰[Note by WEW:] There is no known fact which shows a deviation of the law of proportionality of diamagnetism with the magnetic separating force. Instead of that, although measurements are missing, different facts in favour of this law can be mentioned. The most important one and as well in different aspects the most interesting one is the fact discovered and examined more closely by Plücker, according to which *the same magnetic pole depending on the distance induces in the same material* for example charcoal *diamagnetism or magnetism*. The closer examination which Plücker communicated in Poggendorff's *Annalen* 1848, Vol. 73, pp. 616 et seq., [Plü52], proves, that here *the different distance of the magnetic pole has not to be considered directly* but just *indirectly, as a decrease of the force corresponds to a larger distance*. Plücker namely proved that *the magnetism of charcoal is transformed to diamagnetism by the mere increase of the magnetic force acting on the charcoal*. The simplest explanation for this interesting fact is the above mentioned law of proportionality of diamagnetism with the magnetic separating force, as soon as one assumes the law proved by Müller for the magnetism of iron as well for charcoal. Indeed, if the magnetism of charcoal for increasing separating force approximates a *limit* while the diamagnetism of charcoal increases uniformly, it is obvious that diamagnetism finally has to outmatch the magnetism, meaning that the magnetism of charcoal is transformed into diamagnetism.

After this comparison of the ratio of the magnetic and electromagnetic effects of an *electrodiamagnet* with the ratio of the magnetic and magneto-electric effects of an *electromagnet* the result is confirmed that in the nature of diamagnetism the *electrodiamagnetic* and the *diamagnetolectric* efficacy is actually justified in the same way as in the nature of magnetism the *electromagnetic* and *magnetolectric* one. In fact, the diamagnetic effects in their magnitude have the same ratio as the magnetic ones as far as this can be checked. This proves that between *diamagnetic and magnetic efficacy* in manifold aspects *there is no difference*. This gives a proof of the law mentioned in the Introduction of *diamagnetic polarity*.

It only remained to use the results of the above experiments to determine the ratio between the *strength* of diamagnetism of bismuth and the strength of iron magnetism. The previous discussions make it clear that in general one cannot speak of a *definite* ratio between the diamagnetism of bismuth and the magnetism of iron. Indeed, even if one supposes that the bars of bismuth and iron have the same size and form, this ratio heavily depends on the strength of the magnetic *separating force*. While the diamagnetism is increasing uniformly with increasing separating force, the magnetism approaches a limit. Therefore such a ratio can only be determined under the constraint that the magnetic separating forces are so *small* that the deviation of the magnetism of iron is roughly proportional to these forces. Under this constraint it could be determined the ratio of the *diamagnetism of bismuth* to the *magnetism of iron* using the law of Müller referred to in the footnote 19 of this Section. However, it is advantageous to postpone this determination in order to take into account for the magnetism of iron as well the experiments we get to know in Section 25 and Section 26 where we add the determination of this ratio.

11 The Experiments of Faraday

We do not discuss here the former experiments of Faraday which led him to the assumption which Plücker phrased in the shortest way by saying: “In Bismuth each North pole of a magnet induces a North pole and each South pole a South pole”. Plücker says about this assumption that each physicist has to come up with it and that *diamagnetic polarity* is a necessary consequence of it. We restrict ourselves here to these experiments, which Faraday recently carried out to disprove the by him first conjectured *diamagnetic polarity*.

In fact soon after it was realized how important the actual proof of *diamagnetic polarity* is, many and various facts were found and communicated so that this polarity seemed almost to be beyond doubt. In my first arti-

cle (*Berichte der Königl. Sächs. Gesellschaft der Wissenschaften 1847*, p. 346 and Poggendorff's *Annalen 1848*, Vol. 73, p. 242)^{21,22} I stressed in particular the evidence the experiment of Reich has in this aspect.²³ According to this experiment, if North and South pole act from the same side to a piece of bismuth, they repel it in no way with the sum of the forces they are exerting individually, but rather with the difference of these forces. I added other experiments which allowed to recognize *both poles* of a bar of bismuth in a diamagnetic state by the contrast of *attraction* and *repulsion*. Finally, I added the experiments with the device mentioned in Section 7 which seemed to detect similar *electromotive forces* exerted from *diamagnetic poles* as well as from *magnetic poles*. Some experiments by Poggendorff, *Annalen 1848*, Vol. 73, pp. 475)²⁴ followed immediately, which on the one hand served as a confirmation, on the other hand as a supplement. In particular, they provided evidence for the two *diamagnetic poles* by the contrast of the effect which the *galvanic current* is exerting on them. They downright proved that a bar of bismuth in equatorial position would be an actual *transversal magnet*, which turns the line of its North poles to the North pole and the line of its South pole to the South pole of the magnet. Plücker (*Annalen 1848*, Vol. 73, p. 613) found this confirmed by a very smart application based on that, which provided a simple and practically important mean to intensify considerably the diamagnetism of swinging bodies. Plücker himself declared it beyond doubt that the *diamagnetism* consists of a *polar excitement*. Before that he discarded this theory due to the enormous difficulties to justify it. After polarity was confirmed in such a decisive manner he revived the theory. Finally in this article Plücker overcame one of the most important difficulties mentioned by him, namely the difficulty due to the for many materials observed *magnetic* behaviour in *larger* distance from the magnetic pole and the *diamagnetic* behaviour in *smaller* distance (see the footnote 20 in the previous Section). In view of his closer examination he himself said that

“the by him not believed, but from a theoretical point of view expected result instead of the former difficulties found a remarkable confirmation of the adopted theory of diamagnetism from Faraday, Reich, Weber, and Poggendorff, to which he now became as well a resolute supporter”.

All this confirmations of *diamagnetic polarity* first conjectured by Faraday complemented each other quickly and appeared in the same Volume 73

²¹[Note by HW:] Wilhelm Weber's *Werke*, Vol. III, p. 255.

²²[Note by AKTA:] [[Web48a](#)], [[Web48b](#)], [[Web52c](#)] and [[Web66](#)].

²³[Note by AKTA:] [[Rei48](#)] and [[Rei49](#)].

²⁴[Note by AKTA:] [[Pog48](#)].

of Poggendorff's *Annalen*. However, Faraday himself contradicts it in his 23. series of experiments,²⁵ whose closer consideration is of importance as well for the here described experiments.

In view of the very well deserved authority this great scientist has and the interest his works stir everywhere we can assume that his experiments to disprove *diamagnetic polariy* are well-known. Moreover, there is no doubt on the validity of these experiments in view of Faraday's acknowledged experimental skills. The question is just if and how far these experiments disprove *diamagnetic polarity* as defined here right at the beginning. There are mainly three points to consider. *Firstly*, Faraday did not repeat all experiments carried out to prove diamagnetic polarity. *Secondly*, despite his outstanding skills Faraday restricted himself in the accuracy of the instruments he used. *Thirdly*, Faraday tried to explain in a different way many phenomena which are in the opinion of other physicists due to *diamagnetic polarity*. Therefore it is even not clear if Faraday really contradicts *diamagnetic polarity* in the sense we defined it at the beginning.

Concerning the experiments which are not repeated and considered by Faraday, I first mention that in paragraph 2689 of his article an experiment carried out by me seems to be confused with a one carried out by Reich. Therefore it happened that Faraday completely overlooked the experiment by Reich whose evidence for *diamagnetic polarity* I stressed in particular. According to this experiment North and South pole acting simultaneously from the same side on a piece of bismuth do not repel it with the sum of their individual forces but with their difference. This experiment was carried out by Reich with the most accurate instrument available, namely the torsion balance he used for the classical repetition of the experiments by Cavendish. I can only repeat here what I said in my first article on this experiment, that through it alone it can be deduced with high probability that the reason for the diamagnetic force lies in a moveable imponderable ingredient existing in bismuth which is moved and distributed in different ways when a magnetic pole is approximating it. The simultaneous approximation of two opposite poles from the same side has then namely the effect that the imponderable ingredient neither can assume the one or the other movement or distribution responsible for the appearance of the diamagnetic force, which explains the vanishing of this force. Furthermore one has to mention in this context the experiments carried out by Poggendorff and described in the same volume 73 of his *Annalen* (p. 475–479), through which he obtained by a simple convincing experiment in two ways the same result without the help of subtle measuring devices. There is no difficulty to repeat the experiments by

²⁵[Note by AKTA:] [Far50].

Poggendorff and many observers carried this out.

Among the devices which allow an even higher degree of fineness and accuracy than the ones used by Faraday are mainly the *magnetometer* and the *galvanometer* arranged according to the instructions of Gauss. I would not have been able at all to carry out my experiments without these instruments. When Faraday repeated these experiments without the help of these instruments it is easily explainable that he was not able to see the very weak effects I observed. Faraday's major concern against my observations described in volume 73 of Poggendorff's *Annalen* is, that I did not mention the by him with great care observed *secondary Volta induction*, which I should have been able to see the more clearly the finer my instruments are. Therefore I mention here, that the above article in Poggendorff's *Annalen* borrowed from the "Berichten der Königl. Sächs. Gesellschaft der Wissenschaften"²⁶ was just a preliminary note of my work, where the more specialized discussion was postponed to a later article. It should be sufficient to add here that in those experiments I tried to eliminate the influence of the secondary Volta induction as far as possible by a proper combination of the experiments, that it is however not highly preferable at all to remove this influence completely as happened in the experiments described in this article.

Let us briefly summarize which influence the investigation of Faraday had on the question of *diamagnetic polarity* in the sense as defined at the beginning. This influence should be of minor importance. Faraday namely overlooked several experiments by Reich and Poggendorff. Concerning different experiments, namely the ones by Plücker, he just gave an explanation based on different premises, where it is not clear if these premises contradict *diamagnetic polarity* as defined here at the beginning. Finally, related to the doubt Faraday mentions about the validity of the results of my experiments, *firstly* this doubt should be removed by the remark above, *secondly* it has no application to the experiments described in this article.

12 The Experiments and the Theory of Feilitzsch

In Section 3 and Section 4 it was proved that a bar of bismuth in a galvanic spiral as an *electrodiamagnet* exerts on a magnetic needle a torque in *opposite direction* than an iron bar exerts in the same spiral as an *electromagnet*. This contradicts a result of Feilitzsch who, inspired by a different theory, expected a different result and tried to confirm it by experiments (see Poggendorff's

²⁶[Note by AKTA:] [Web48b], [Web48a], [Web52c] and [Web66].

Annalen 1851, Vol. 82, p. 90–110).²⁷ Namely he thought that:

“bismuth inside the electric spiral receives a weaker, but equally directed polarity, as soft iron.”

The reason for this contraction as I believe lies in a very essential difference of the devices used by me and Feilitzsch. Feilitzsch mentioned that “the spiral was deployed at a distance of about 200 millimeters on the western side from a small compass suspended on a cocon thread and the needle was brought back to its initial position *by an auxiliary magnet on the eastern side*”. In contrast to that I used two spirals and deployed them symmetrically with respect to the compass so that no *auxiliary magnet* was necessary to bring back the needle to its initial position. The crucial difference of the two arrangements is that in Feilitzsch’s case the needle only for a *determined current intensity* lies in the magnetic meridian, but is deflected to either side for each *variation* of the current intensity. On the other hand in my case the variations of the current intensities have no influence on the position at rest of the needle. However, this *independence of the position at rest of the needle from the variations of the current intensity in the spiral* is necessary if the deflection of the needle has to be associated to *the immediate effect of the bar of bismuth on the needle* when the bar of bismuth is put into the spiral. Namely putting the bar of bismuth into the spiral effects a small change of the intensity of the current and this might be in Feilitzsch case the reason for the deflection of the needle. Namely putting the *cold* bar of bismuth into the spiral *heated* by the current leads to a *cooling* of the spiral and therefore an *increase* of the current intensity, which necessarily creates a *deflection of the needle in the direction observed by Feilitzsch*. A long time ago I carried out several experiments according to the same method as Feilitzsch and found similar results. However, a closer examination showed, that the observed force did *not* appear *instantaneously* in the moment the bar of bismuth entered, but rather *gradually*. Also when pulling out the bar the force disappeared *gradually*, what is a sufficient proof that it is not a matter of an *instantaneous* action of the bar of bismuth. One could also increase, decrease, or reverse these influences through a mere cooling or heating of the bar of bismuth. It is likely, that as well the deflections of the needle observed by Feilitzsch are due to the influences of temperature on the intensity of the current.

Concerning the *theory of diamagnetism* which Feilitzsch tried to give in this context, I just want to mention the following. Feilitzsch wants to explain the diamagnetic phenomena from a certain distribution of magnetic fluids,

²⁷[Note by AKTA:] [Fei48].

too. However, he assumes that this distribution is due to the *separation of magnetic fluids in the same direction as in iron* and that the only difference is that this separation in an iron bar *decreases* from the middle to the ends, while in the bar of bismuth it *increases*. It follows from this *increase* between the middle and the end of the bar a dispersion of opposite free magnetism as at the end, and if this opposite between the middle and end dispersed free magnetism *were stronger*, than the one at the end, the diamagnetic phenomena could be explained. However, if Feilitzsch examined the conditions more closely which lead to an explanation of the diamagnetic phenomena according to his own presentation, he would have found that this case is only possible, if the magnetic fluids in the middle of the bar are not separated in the same but in opposite directions as at its ends, which contradicts his assumptions. Anyway, one easily sees that it is impossible to explain the diamagnetic phenomena from a distribution of magnetic fluids arising from the *same separation as in iron according to the direction*.

13 On the Connection Between the Theory of Diamagnetism with the Theory of Magnetism and Electricity

In the first two parts of this paper I tried to establish the law of *diamagnetic polarity* in more generality, mainly by showing that it is valid as well for *electrodiamagnetic* and *diamagnetic* actions. This law alone even if it is general does not establish yet a *theory of diamagnetism*. This is because it only defines diamagnetism in view of its *effects*. However for the foundations of a theory of diamagnetism it is necessary to define it not just in view of its effects but as well in view of its *causes*. Therefore, I will add in this part the necessary complement to the theory on the *causes* of diamagnetism in more generality than what I did in my previous paper.

14 On the Way How to Examine the Causes of Diamagnetism

In the theory of magnetism one distinguishes two types of magnets, namely *permanent* ones and *variable* ones. For example a magnet made of glass-hard steel is a permanent one, while a magnet made of soft iron is a variable one. Strictly speaking in reality there is not a strict distinction between permanent and variable magnets, since even the most permanent ones become variable

under the influence of strong forces, and in the same way all magnets even the ones made of the most soft iron become permanent under the influence of very small forces. However, since one usually chooses for physical experiments magnets and conditions under which either the permanent or variable aspect of the magnet does not show up, one can assume without loss of generality this simple distinction. For the sequel we point out the following difference between the two kinds of magnets. The permanent ones can only be examined in view of its *effects*, while the variable ones in two ways, namely in terms of its *effects* as well as in terms of its *causes*.

If one tries to apply this distinction to diamagnets, one sees, that *permanent diamagnets* do not exist, or more precisely, that they cannot be distinguished from permanent magnets. Therefore, one only needs to consider *variable diamagnets* and these can be examined in two ways partly by their *effects* and partly by their *causes*.

It is known, that by examining the effect of a magnet on other materials one can obtain the *ideal distribution* of the magnetic fluids on its surface. Gauss has shown that if one knows the *ideal distribution* one can predict all *effects* of the magnet.²⁸ Many researches take great profit that through its knowledge one does not need any hypothesis about the interior of the material, particularly, if the causes of these effects are unknown and first have to be examined. It is obvious from this that by examining the effects one cannot get further than to the knowledge of the ideal distribution which has to be distinguished necessarily from the true nature of the interior of the magnet. For example, it is not possible by examining the effects to get to know the actual distribution of the magnetic fluids in the magnet or the actual number, strength and position of the electric currents inside.

The same is therefore true as well for the effects of a diamagnet. One could get knowledge of the *ideal distribution* of magnetic fluids at the surface of the diamagnet and this replaced the knowledge of its whole true internal state concerning the consideration of all its effects. On the other hand one would not get information about the true internal state of the diamagnet nor the actual nature of diamagnetism nor its generation and transformation. To get a clue of these one must not restrict oneself to the consideration of the *effects* and the *ideal distribution* depending on it, but it is necessary to take into account different points of view which are independent of these effects.

All possible *causes* of *diamagnetism*, as well as of magnetism, can be classified into *internal* and *external* ones. The *external* cause, as the effects, is given through observation. It is the same for magnetism and diamagnetism, namely *a magnetic or electromagnetic separating force having determined size*

²⁸[Note by AKTA:] [[Gau39](#)], [[Gau41a](#)] and [[GT14](#)].

and direction. Would we know apart from this external cause the internal one in the material itself, then diamagnetism would be determined. Conversely, this opens a way to determine the unknown internal cause if, in addition to the known external cause, the diamagnetism resulting from both is already known from its effects. If one follows the way sketched here and lists as well for iron and bismuth the known magnetic separating forces together with the from the effects deduced ideal distribution, one observes that the same separating force leads to opposite ideal distributions or conversely the same ideal distribution for iron and bismuth gives rise to opposite separating forces. The reason that opposite external causes produce the same effects in iron and bismuth has to be contained in the difference of *internal* causes in iron and bismuth themselves. To determine more closely the *difference of internal causes* in iron and bismuth it is necessary to classify all possible internal causes which can have such effects explainable in terms of an ideal distribution. After that one has to check if among these possible internal causes there are some which can give rise to the above mentioned differences in magnetic and diamagnetic materials.

15 Classification of Internal Causes which Can Give Rise to the Given Effects of an Ideal Distribution

One can give *four* essentially different kinds of *internal* causes contained in the materials which can give rise to such effects explainable in terms of an ideal distribution of magnetic fluids.

1. The internal cause of such effects can be due to the existence of two *magnetic* fluids which are more or less *movable independently from their ponderable carrier*.

2. It can be due to the existence of two *magnetic* fluids which are only *movable with the molecules of their ponderable carrier*, i.e., rotating molecular magnets.

3. It can be due to the existence of *permanent molecular currents built from the two electric fluids*, which can be rotated with the molecules.

4. It can be due to the existence of two *movable electric fluids*, which can become a molecular current.

These four here mentioned possible internal causes of the effects due to an ideal distribution at the surface are the only ones which are known and can be examined. The *first* case is the base of the theory of magnetism developed by Coulomb and Poisson. The *third* case is the base of the theory

of magnetism using electrodynamics developed by Ampère. The *second* case can be reduced to the third one in view of the theorem due to Ampère that molecular magnets and molecular currents coincide in all their effects if one substitutes the first one for the latter one. It therefore just remains the *fourth* case which was not noticed and discussed before.

16 Dependence of the Ideal Distribution on the Magnetic Separating Force According to the Difference of the Four Above Mentioned Possible Internal Causes

For each of these four cases one easily obtains a connection between the type of *ideal distribution* and the *direction of the magnetic separating force* giving rise to the distribution. For the *first* case it follows according to the theory of Poisson, that if one denotes the direction of the magnetic separating force as the *positive* one in which the North pole of a magnetic needle points and if one determines the barycenters of the northern and southern fluid corresponding to the separating force of the corresponding ideal distribution, the former of these two barycenters is displaced in the *positive* direction with respect to the latter one. For the *third* case this connection was developed by Ampère and it follows that it leads to the same dependence of the ideal distribution from the magnetic separating force. It is obvious that the same dependence holds as well for the *second* case since the second case can be deduced from the third one as mentioned above. It therefore remains to discuss just the *fourth* case.

This *fourth* case assumes the existence of *electric fluids* which can become molecular currents. The possibility that such molecular currents develop is based on the assumption that in single molecules or around them there are closed orbits in which the fluids are movable *without resistance*. It follows from this, that only a *current-inducing force*, i.e., a force which acts on the positive and negative fluid in opposite directions, in the direction of this orbit is required to actually move the fluids in this orbit. The theory of magnetoelectricity implies that due to an increasing or decreasing intensity of the magnetic separating force actually an *electromotive force* is given, which acts on the two movable electric fluids in opposite direction and therefore has to induce a current. The *direction of the molecular current* is given by the fundamental law of magnetic induction depending on the increase or decrease of the magnetic separating force. Moreover, the *ideal distribution* is given in

its dependence of the molecular currents according to the connection between electrostatics and the theory of magnetism discovered by Ampère for the third case. It follows from that the connection between the *ideal distribution* and the *increase or decrease of the magnetic separating force* corresponding to the distribution.

Moreover, it is clear from this that *in each moment* where an increase or decrease of the magnetic separating force occurs, such a molecular current is induced. Therefore the induced currents, if they do not cancel each other, have to be summed up. However, these currents do not disappear by themselves. Indeed, Ampère has shown that one has to associate to electrical molecular currents *permanence*, i.e., that the electric fluids on their circular motions around the ponderable molecules are not subject to such a *resistance* like the electric fluids flowing through a conductor which gives rise to an explanation for the quick disappearance of the electric currents in these conductors. (This *permanence* proved by Ampère for the molecular currents is the reason for the above mentioned theorem that the *possibility* to put electric fluids in a molecular current has as its hypothesis that there exist *closed orbits* in the individual molecules in which fluids can move *without resistance*.) It follows from this that through *continued* increase of the magnetic separating force *in the ideal distribution*, there has to occur a *continued* increase of magnetic fluids as well. It follows from this, that to *each given strength of the magnetic separating force there coincides a certain amount of ideally distributed fluids*. However, this summation only takes place for *molecular currents*, since only for them the movement of electric fluids has *no resistance*. The other currents, which are induced from the same separating force in additional orbits, which however due to the *resistance* they are subject in these orbits disappear quickly, only have magnetic effects on other materials *in the moment they are induced*. These effects immediately vanish as soon as the separating force, which was the reason for the *change*, becomes *constant*. Therefore they are in no determined ratio to the *existing* separating force, what would be necessary, if they should account for the observed magnetic effect for which therefore only *molecular currents* are useful. If one develops this dependence on the *molecular currents* more carefully according to the laws of *magnetic induction*, one finds, that when one denotes this direction as the *positive* one to which the North pole of a magnetic needle points and when one determines the ideal distribution of the barycenters of the northern and southern fluid depending on the separating force, that the former one of these two barycenters is displaced with respect to the latter one in the *negative* direction, i.e., *opposite to the other three cases*.

17 Internal Cause of Diamagnetism

This remarkable result can now be applied to justify the theory of diamagnetic phenomena which explains the internal state of a diamagnetic material and the forces responsible for it. Such a justification was not available before. In fact, it does not suffice for such a theory that one is able to represent the diamagnetic state of a material in connection with all its effects by an *ideal distribution* of magnetic fluids on its surface as already argued above. But it is essential to justify as well these *forces* through which that state occurred and, moreover, *on what* these forces act and *according to which laws* they act.

From the compilation and consideration of the possible cases above, through which a state of a material can occur representable by an *ideal distribution* of magnetic fluids, we found *only one [case]* compatible with the *fundamental phenomena* during the *emergence* of diamagnetism. It follows from this, that one can explain the emergence of a diamagnetic state of a material only if one assume that this case *really exists*. Namely the case where the diamagnetic state emerges due to the induced forces which acted on the material and *the electric fluids in the material which move without resistance on circular orbits*. Therefore one assumes that a bar of bismuth consists of molecules which *contain closed orbits* (or canals), *in which the electric fluids can move without resistance*, while in all other orbits they can only move after overcoming a resistance proportional to its velocity. The occurrence of a *pure* diamagnetism not intermingled with magnetism also requires, that the molecules together with those orbits or canals *cannot be rotated*. Otherwise *rotating molecular currents* would emerge leading to a *magnetic state*, if during the rotation their intensity does not change, as proved by Ampère.

18 Determination of the Electromagnetic Separating Force in a Galvanic Spiral

According to the presentation given above it is not the *magnetic or electromagnetic separating force* itself which is responsible for the diamagnetic state of a material, but this separating force determines diamagnetism only indirectly as far as *the sum of the electromotive forces* is concerned which before acted on the diamagnetic material and put the electric fluids into motion around the individual molecules. *The strength of the now existing (induced) molecular currents* which is the nature of *diamagnetism* depends on the *sum* of the electromotive forces having acted on the diamagnetic material. In this way the determination of the *intensity* of the *existing* magnetic or elec-

tromagnetic separating force is used only *indirectly* to the determination of *diamagnetism* since it gives rise to the *integral value of all changes* to which the magnetic or electromagnetic separating force was subject. To this integral value the sum of the electromotive forces and consequently the strength of the now existing (induced) molecular currents is proportional.

Suppose the wire of a galvanic current spirals uniformly around a cylindrical tube. Denote the *electromagnetic separating force* of the current at the midpoint of the tube in direction of the axis by X . According to the known electromagnetic laws it is given by

$$X = \frac{2\pi ni}{d}$$

where n is the number of windings, i is the intensity of the current, and $2d$ the diagonal of the tube (i.e., when $2a$ is the length of the tube and $2r$ is the diameter, then $d = \sqrt{a^2 + r^2}$).²⁹ If the intensity of the current i is expressed according to the in the previous paper on electrodynamic measurements (page 321 of this Volume)³⁰ determined absolute mass, then in the expression above the *electromagnetic separating force* is given by the same measure, which Gauss used for the determination of the *intensity of terrestrial magnetism*.³¹ Strictly speaking the stated value of the *electromagnetic separating force* is valid only for the midpoint of the spiral. In most cases this value can be used with sufficient accuracy for a very large part of the space surrounded by the spiral, in particular, if the diameter of the spiral

²⁹[Note by WEW:] In fact if r is the radius of a winding, x is the distance of its midpoint from the midpoint of the spiral, $r d\varphi$ the length of a current element and i the current intensity, it is well-known that $ir^2 d\varphi / (r^2 + x^2)^{\frac{3}{2}}$ is the expression for the force due to the current element in the midpoint of the spiral in direction of the axis. It follows from this that the expression of the force due to the whole winding is $2\pi r^2 i / (r^2 + x^2)^{\frac{3}{2}}$, and the expression for n windings of the spiral whose length is $2a$ becomes $2\pi r^2 i \cdot \frac{n}{2a} \int_{-a}^{+a} \frac{dx}{(r^2 + x^2)^{\frac{3}{2}}}$, i.e., if one sets $\sqrt{a^2 + r^2} = d$ one obtains $\frac{2\pi ni}{d}$.

³⁰[Note by AKTA:] [Web52b, p. 321 of Weber's *Werke*].

³¹[Note by AKTA:] Gauss's work on the intensity of the Earth's magnetic force reduced to absolute measure was announced at the Königlichem Societät der Wissenschaften zu Göttingen in December 1832, [Gau32]. The original paper in Latin was published only in 1841, although a preprint appeared already in 1833 in small edition, [Gau41b] and [Rei19]. Several translations have been published. There are two German versions, one by J. C. Poggendorff in 1833 and another one in 1894 translated by A. Kiel with notes by E. Dorn; a French version by Arago in 1834; two Russian versions, one by A. N. Drašusov of 1836 and another one by A. N. Krylov in 1952; an Italian version by P. Frisiani in 1837; an English extract was published in 1935, while a complete English translation by S. P. Johnson and edited by L. Hecht appeared in 1995; and a Portuguese version by A. K. T. Assis in 2003: [Gau33], [Gau34], [Gau36], [Gau37], [Gau94], [Gau35], [Gau52], [Gau75], [Gau95] and [Ass03].

compared to its length is very small. For example if one considers a point on the axis which has the distance b to the midpoint of the spiral one obtains for this point

$$X = \frac{\pi ni}{a} \left[\left(1 + \frac{r^2}{(a-b)^2} \right)^{-\frac{1}{2}} + \left(1 + \frac{r^2}{(a+b)^2} \right)^{-\frac{1}{2}} \right],$$

or if one replaces a by $\sqrt{d^2 - r^2}$ and r/d by ρ

$$X = \frac{2\pi ni}{d} \left[1 - \frac{3d^2 - b^2}{2(d^2 - b^2)^2} \cdot \rho^2 b^2 + \dots \right].$$

If the difference of the electromagnetic separating force and its maximal value at the midpoint shall be less than a small fraction m times the maximal value one sets

$$\frac{3d^2 - b^2}{2(d^2 - b^2)^2} \cdot \rho^2 b^2 = m$$

or

$$\frac{b^2}{d^2} = 1 + \frac{\rho^2}{4m + 2\rho^2} \left(1 \pm \sqrt{\frac{16m}{\rho^2} + 9} \right).$$

Hence if the diameter is for example the 40th part of length, then in more than $\frac{7}{8}$ of the whole from the spiral enclosed space the electromagnetic separating force is up to 1 percent constant and in almost $\frac{2}{3}$ of this space it is constant up to $\frac{1}{10}$ percent.

Therefore such spirals can be used to provide in an easy way an arbitrarily long space in which the electromagnetic separating force has an exactly known, arbitrarily big and everywhere constant magnitude. The representation of such a space is however of great importance for many studies and the experiments described in the previous two Sections can serve as examples for this. In fact without using spirals it would have not been possible to carry out these experiments.

Strictly speaking the discussion above deals only with the points laying on the axis of the spiral. However, the result found can easily be extended to the remaining space enclosed by the spiral using a general theorem of Gauss in the “General theory of terrestrial magnetism” (Resultate aus den Beobachtungen des magnetischen Vereins im Jahre 1838), article 38.^{32,33}

³²[Note by HW:] Gauss’ *Werke*, Volume 5, p. 170.

³³[Note by AKTA:] [[Gau39](#)], [[Gau41a](#)] and [[GT14](#)].

19 Determination of Electrodiamagnetism Using the Electromagnetic Separating Force

The integral value of the electromotive force on a circle of radius r for the time needed to move the circle from the perpendicular position with respect to the separating force to a parallel one was determined in the previous paper on electrodynamic measurements (page 323 of this Volume).³⁴ For the electromagnetic separating force given by $X = 2\pi ni/d$ one obtains

$$= \pi r^2 X .$$

This integral is the *product* of the *intensity* with the *element of time* during which the force with this intensity is acting.

The expression is unchanged if instead of turning the circle by 90° the electromagnetic separating force $X = 2\pi ni/d$ *vanishes*. On the other hand if this separating force is increased from $X = 0$ to $X = 2\pi ni/d$ (by closing the current), then the expression becomes

$$-\pi r^2 X = -\frac{2\pi^2 nr^2 i}{d} .$$

The *negative* sign means, that the induced current has such a direction, that the poles of a molecular magnet *equivalent* to it get an opposite orientation than the poles of a compass under the influence of the same force X .

For the determination of the *integral value* of the electromotive force we used the measure of electromotive forces deduced from the absolute measure of *magnetism* as explained in the previous paper, page 321.³⁵ For the purely *electrodynamic* measure this expression has to be multiplied by a factor $\sqrt{\frac{1}{2}}$, page 361 *ibid*, hence

$$-\frac{\pi}{\sqrt{2}} \cdot r^2 X = -\frac{\pi^2 \sqrt{2} \cdot nr^2 i}{d} .$$

According to the previous paper this expression has to be multiplied (page 367 *ibid*) by $4/c$ (where c denotes the constant value of the relative velocity for which two electric masses do not influence each other), if one wants to express the electromotive force in terms *of the absolute measure of forces utilized generally in mechanics*, hence

$$-\frac{2\sqrt{2}}{c} \cdot \pi r^2 X = -\frac{4\sqrt{2} \cdot \pi^2 nr^2 i}{cd} .$$

³⁴[Note by AKTA:] [[Web52b](#), p. 323 of Weber's *Werke*].

³⁵[Note by AKTA:] [[Web52b](#), p. 321 of Weber's *Werke*].

This expression gives *the electromotive force for the length of the circular orbit* under the assumption that in each unit of length of this orbit the electric fluid is located. One obtains from this *the electromotive force acting on each unit of mass of the electric fluid* by division of the circumference of the circle $2\pi r$

$$= -\frac{\sqrt{2}}{c} \cdot rX = -\frac{2\sqrt{2} \cdot \pi nri}{cd},$$

i.e., the *integral value of the acceleration* for the interval of time in which the electromagnetic separating force grew from $X = 0$ to $X = 2\pi ni/d$, in case to each particle of the electric fluid a ponderable unit of mass is attached. If ε denotes the unknown little fraction which expresses the unit of the mass belonging to the electric fluid in terms of the ponderable mass measure, we obtain by dividing the above expression by ε the *velocity of the current* u produced by the *increase of the electromagnetic separating force*. If one multiplies this expression of the *velocity of the current* u by $ae = 4e/c$ (see p. 367 *ibid*),³⁶ where e is the amount of the electric fluid expressed in terms of electric measure which is located in each unit of length of the circular orbit, one obtains the *intensity* of the *induced* circular current according to the measure derived according to purely *electrodynamic* principles (see p. 359 *ibid*). If one multiplies further this formula by $\sqrt{2}$ one obtains the intensity in terms of the measure according to which a current of intensity = 1 acts identically with the *unit of magnetism* according to absolute measure if it orbits around the unit of area, namely

$$-\frac{8e}{c^2\varepsilon} \cdot rX = -\frac{16\pi nrei}{c^2d\varepsilon}.$$

Here i denotes the intensity of the *induced* current according to the same measure.

The *electromagnetic moment* of this induced circular current (molecular current) is found by multiplying the *intensity of the current* stated above by the area πr^2 enclosed by the circular orbit

$$= -\frac{8e}{c^2\varepsilon} \cdot \pi r^3 X = -\frac{16\pi^2 nr^3 ei}{c^2d\varepsilon}.$$

Here one assumes that the *normal* of the plane containing the circular orbit is parallel to the *direction* of the electromagnetic separating force. This can happen for *all* circular orbits only for a *particular* arrangement of the molecules. In case of *bismuth* we do not assume such an arrangement, but instead suppose according to the notion of *homogeneity* that the normals of

³⁶[Note by AKTA:] [[Web52b](#), p. 367 of Weber's *Werke*].

the circular orbits do not have a prevailing direction. Hence the number of circular orbits whose normals have an angle φ with respect to the direction of the electromagnetic separating force is proportional to $\sin \varphi$. Therefore the *intensity of the current* is proportional to $\cos \varphi$ and the *component parallel to the separating force* to $\cos^2 \varphi$. It follows that multiplying the expression above by $\sin \varphi \cos^2 \varphi$ one obtains an expression proportional to the part of the *electrodiamagnetic moment* of bismuth coming from all circular currents (molecular currents) whose normals have an angle φ to the direction of the separating force, namely

$$-\frac{8e}{c^2\varepsilon} \cdot \pi r^3 X \cdot \sin \varphi \cos^2 \varphi = -\frac{16\pi^2 nr^3 ei}{c^2 d\varepsilon} \cdot \sin \varphi \cos^2 \varphi .$$

Integrating first this expression from $\varphi = 0$ to $\varphi = \frac{1}{2}\pi$ with respect to $d\varphi$ and multiplying the obtained *integral value* with the number of molecular currents m , one gets the whole *electrodiamagnetic moment* of bismuth expressed by

$$= \frac{8e}{3c^2\varepsilon} \cdot \pi mr^3 X = -\frac{16\pi^2 mnr^3 ei}{3c^2 d\varepsilon} .$$

If v denotes the *volume* of bismuth and a the *distance* of the midpoints of its molecular currents whose radius is $= r$, the number of its molecular currents is $m = v/a^3$. Under the assumption that the size of molecular currents is proportional to the supply of molecules, i.e., $a/r = \varkappa$ is constant, the sum of the areas orbited by all molecular currents is $m\pi r^2 = \pi v/\varkappa^3 r$. Substituting this value in the above expression of the electrodiamagnetic moment, one obtains

$$-\frac{8\pi}{3c^2\varepsilon} \cdot \frac{e}{\varkappa^3} \cdot v X = -\frac{16\pi^2 ni}{3c^2 d\varepsilon} \cdot \frac{e}{\varkappa^3} \cdot v .$$

Hence the *electrodiamagnetic moment* of a mass of bismuth is proportional to the *electromagnetic separation moment* X and the volume v and can be found by multiplication of the constant factor $8\pi/3c^2\varepsilon$ extractable from the *general theory of electricity* and the constant factor $-e/\varkappa^3$ depending on the *nature of bismuth*. This last factor one can call the *diamagnetic constant* of bismuth.

20 Comparison of the Interaction of Diamagnetic Molecules with the Interaction of Magnetic Molecules

In the previous Section the induction of molecular currents in the circular orbits of molecules was considered *individually* to determine the *electrodia-*

magnetic moment, as if on each molecule just the electromotive force acted determined by the existing *electromagnetic separating force*. Strictly speaking this is not the case, but instead in each circular current in addition acted the electromotive forces coming from the *interaction* of diamagnetic molecules, likewise as if on the particles of an iron bar not just the external separating force due to terrestrial magnetism acted but as well the separating forces coming from the interaction of the particles in the bar.

If one wants to take account of this *interaction* although it is so small that its influence is hardly noticeable, it is worthwhile to stress a remarkable contrast which takes place between the interaction of *diamagnetic* and *magnetic* molecules.

Namely, if two *iron particles* lay on a line *parallel* to the direction of the magnetic separating force acting on them and if one denotes by m the *magnetic moment* which was produced by the separating force in each of the iron particles *individually*, the new separating force resulting from the interaction of the particles *increases* the moment m . This new separating force due to the *interaction* of the two particles is expressed according to known laws by $2m/r^3$, when r denotes the distance of the particles. The *total* separating force $(X + 2m/r^3)$ produces now in the particle under examination a *larger* moment $= (1 + 2m/Xr^3)M$. On the other hand if two *particles of bismuth* lay on a line *parallel* to the electromagnetic separating force acting on them, and if one denotes the *diamagnetic moment* corresponding to this separating force by $-\mu$ (the negative sign means that for separating forces acting in the same direction the diamagnetic moment is opposite to the magnetic one), the resulting separating force due to the interaction between the particles is $= -2\mu/r^3$ if r is the distance between the two particles. Therefore to the *total* separating force $= (X - 2\mu/r^3)$ corresponds the *decreased* moment $-(1 - 2\mu/Xr^3)\mu$. Hence the *contrast* is that magnetism for iron particles laying *in the direction of the separating force* gets *intensified* by interaction, while diamagnetism for particles of bismuth laying in this direction gets *weakened* by interaction.

The opposite phenomenon occurs if the particles of iron and bismuth lay on a line *perpendicular* to the direction of the separating force. In this case the magnetism of iron particles gets *weakened* by interaction while diamagnetism of particles of bismuth gets *intensified* by interaction. In fact by using the same notation the *weakened magnetism* of iron particles results in $= +(1 - m/Xr^3)m$, while the *intensified diamagnetism* of particles of bismuth results in $= -(1 + \mu/Xr^3)\mu$.

It follows from this, that to endow a given mass of iron for a given separating force with the strongest magnetism one brings it in the form of a long and thin bar or a *prolate* ellipsoid whose major axis is *parallel* to the

direction of the separating force, whereas on the other hand one has to bring a mass of bismuth to endow it with the strongest *diamagnetism* to the form of a plate as thin as possible or in the form of an *oblate* ellipsoid whose *minor* axis is *parallel* to the direction of the separating force. This conclusion could be checked experimentally, but one has to take account that in case of bismuth the influence of the interaction of the particles is very small due to the weakness of the diamagnetism corresponding to a given separating force. However, if one applies the result found to the verification of the theorem first mentioned by Faraday that bismuth under the influence of magnetic separating forces behaves exactly as iron with the only difference that the two magnetic fluids seem to be interchanged, it turns out that this theorem is not completely true. In fact according to Faraday's theorem the prolate elliptic form would be for bismuth as for iron the most favorable one to get the strongest diamagnetism respectively the strongest magnetism, what is not the case. The deduction of these laws of interaction of diamagnetic molecules compared to the interaction of magnetic molecules leads to a simple distinction between magnetic and diamagnetic materials which is the topic of the following Section.

21 Distinction of Magnetic and Diamagnetic Materials with the Help of Positive and Negative Values of a Constant

Instead of the not completely accurate distinction between magnetic and diamagnetic materials, where for the same separating force the two magnetic fluids are just interchanged, it is possible to give an alternative correct and equally simple distinction which takes advantage of the difference of the values of a *constant* derived from the nature of each material.

In fact if one considers for simplicity just a *rotationally invariant ellipsoid* of iron or bismuth whose major axis is parallel to the direction of the separating force it was proved by Neumann in Crelle's "Journal für die reine und angewandte Mathematik", volume 37,³⁷ that *in case of iron* for the given separating force X the magnetic moment of the ellipsoid is given by the expression

$$\frac{kvX}{1 + 4\pi kS}$$

where v is the volume of the ellipsoid and S is a quantity determined by the

³⁷[Note by AKTA:] [Neu48].

ratio of the axes. Namely,

$$S = \sigma(\sigma^2 - 1) \left\{ \frac{1}{2} \log \frac{\sigma + 1}{\sigma - 1} - \frac{1}{\sigma} \right\}$$

and

$$\sigma = \sqrt{1 - \frac{r^2}{\lambda^2}} .$$

Here r and $\sqrt{r^2 - \lambda^2}$ are the axes of the ellipsoid. The finite number k has for iron a constant value depending on its nature which Neumann denotes as the *magnetic constant* of iron. This value is for iron and *all magnetic* materials necessarily *positive*.

The value of S for an *infinitely long ellipsoid* is $S = 0$. Consequently the magnetic moment is

$$= kvX ,$$

hence for $v = 1$ and $X = 1$ the magnetic moment $= k$. Therefore *the magnetic constant* k can be defined as the *limit* which the magnetic moment approaches under the unit of the magnetic separating force, if the ellipsoid of volume one gets more and more prolate. Since the constant k for all magnetic materials is positive, the magnetic moment is positive or negative, depending if the separating force is positive or negative.

For a *ball* one obtains the value $S = \frac{1}{3}$, consequently the magnetic moment is

$$= \frac{kvX}{1 + \frac{4}{3}\pi k} .$$

This formula implies, using that k is positive for a piece of iron in form of a ball, there is less magnetism as for a prolate ellipsoid in case the volume is fixed.

For an infinitely thin disklike plate the value of S equals one, consequently the magnetic moment is

$$= \frac{kvX}{1 + 4\pi k} .$$

The quantity k can now be used to distinguish different *magnetic* substances. According to the difference of the substances its value can decrease to zero, but, according to *the nature of magnetism* it always remains *positive*. However, one can generalize the applicability of the quantity k as a mean to distinguish substances by not restricting it to magnetic materials but extending it to all materials, by assigning a *negative value* of k which has the physical significance that a material having such a *negative* value of k is not magnetic but *diamagnetic*. Instead of introducing negative values of k we will write for *diamagnetic* materials $-k$. The diamagnetic moment of an ellipsoid

of bismuth whose volume = v and on which the electromagnetic separating force X acts parallel to direction of the main axis can therefore be expressed as

$$-\frac{kvX}{1 - 4\pi kS} ,$$

where S has the same meaning as above. For infinitely long ellipsoids, where $S = 0$, the diamagnetic moment is

$$= -kvX ,$$

for a ball where $S = \frac{1}{3}$ it becomes

$$= -\frac{kvX}{1 - \frac{4}{3}\pi k} ,$$

and for an infinitely thin ellipsoid where $S = 1$ it is

$$= -\frac{kvX}{1 - 4\pi k} .$$

Hence if one fixes the volume for the *most prolate* form there is the *least* diamagnetism, where for the *most oblate* form there is the *most* diamagnetism, precisely opposite as in the case of magnetism, which was already proved in the previous Section.

However, since $-k$ has a very *small* value even in case of bismuth which is the most diamagnetic one, it follows that the diamagnetism of bismuth always is almost proportional to the product of the volume with the separating force and can be considered as roughly independent of the shape. Therefore the meaning of $-k$ can be directly compared with the one of the *diamagnetic constant* which we discussed at the end of Section 19. There as well the diamagnetic moment was expressed as the product of the volume and the separating force with a *constant coefficient* which decomposed into two factors, namely a factor $8\pi/3c^2\varepsilon$ obtained from the *general theory of electricity* and a factor $-e/\varkappa^3$ depending on the *nature of bismuth* which was referred to as the *diamagnetic constant* of bismuth. One easily sees that these two factors are not separated here in $-k$ and that $-k$ has precisely the meaning of the product of these two factors.³⁸

³⁸[Note by WEW:] We would like to mention that the *magnetic* coefficient k is only *constant* according to the theory of *separable magnetic fluids* (Section 15, number 1), but according to the theory of *rotatable molecular magnets* (Section 15, number 2) has to be a function of the separating force. On the other hand, the *diamagnetic* coefficient $-k$ according to the theory of diamagnetolectric induction (Section 15, number 4) by

22 On the Existence of Magnetic Fluids

When a certain class of effects of a material on an other material is such that it can be explained in terms of an *ideal distribution* of magnetic fluids on its surface, one can think of different possibilities for the true causes of all those effects which lay in the *interior* of the material and one can distinguish four different cases, which were mentioned in Section 14 and discussed in more detail in the following Sections. Two of these cases assume that there exist *two magnetic fluids* to which in the molecules of the material either a *constant* or *variable* separation is assigned. The other two cases have as hypothesis, that the two according to the theory of electricity existing *electric fluids* are in a certain circular orbit around each of the molecules of the material either in a *constant* or *variable* current. As one easily sees these four different cases are not mutually exclusive at all. Indeed, a part of the magnetic fluids in the molecules can be separated constantly whereas the separation of another part is variable. In the same way a part of the electric current for the circular orbits of each molecule can be constant while the intensity of another part varies. In fact without a *variable part* the *constant* currents cannot exist in view of the many existing electromotive forces. Namely the electric fluids if they are actually freely movable in certain circular orbits around the molecules as is shown by the existence of persistent currents, they need to follow necessarily the impetus of the electromotive forces decomposed according to the direction of the circular orbits. Therefore the first and second case can occur either individually or in combination. The third and fourth case however are in a necessary relation to each other so that either none of these cases or both together have to occur. It follows that the four cases mutually combined can be distinguished into two main cases. Namely, in the first place that two separated or separable *magnetic fluids* exist in the molecules of the material. Secondly that the according to the theory of electricity everywhere existing *electric fluids* are *freely movable* in certain circular orbits around the molecules. These two main cases however can be considered as mutually exclusive as far as the *actual proof of existence* of one case leaves the other as a *superfluous* hypothesis.

For each of the main cases a *theory* can be developed and each of the theories can be split *into two parts*, namely a part where both theories agree in their results and into one where they contradict each other. The same

its nature is *constant*, as shown in Section 19. In Sections 23-26 we will prove that in connection with *magnetism*, experience is in contradiction to the theory of *separable magnetic fluids* and decides in favor of *rotatable molecular magnets* (or molecular currents Section 15, number 3), since the value of k for iron is in reality *not constant*, but depends on the size of the separating force X .

happened in optics concerning the theory of emission and the wave theory which in their results in many aspects *agreed* with each other until the discovery of *interference phenomena* led to a closer discussion of that part for which the two theories *contradict* each other in their results. Although until now the two theories based respectively on the existence of *magnetic fluids* and on the existence of *electric molecular currents* agreed admirably in many respects in their results, it is fair to expect here as in optics that finally the discovery of a new class of phenomena leads as well to a closer discussion of that part in which the two theories disagree in their results so that the newly discovered phenomena decide between the two theories.³⁹

The two optical theories disagreed in their conclusions concerning the *coincidence* of two homogeneous rays of light. According to one theory amplification should always occur while according to the other theory sometimes amplification and sometimes cancellation takes place. The *phenomena of interference* confirmed the results of the *wave theory*. In a similar way the crossroad of our theories can be decided. In fact both agree firstly in all results concerning the phenomena of *permanent* magnets. Secondly they agree as well concerning variable magnets, insofar as each of them leads to a distinction of them *into two classes*, namely into the class of that magnets whose magnetism is due to *the mere orientation of already existing movable molecules* (molecular magnets or molecular currents) and into the class of magnets whose magnetism is due to *the separation and movement of imponderable fluids in molecules at rest* (the separation of magnetic fluids in the molecules or the induction of electric currents in certain circular orbits around the molecules). Finally the two theories agree in their results thirdly concerning the *first* class of variable magnets. However, *they contradict each other in their results concerning the second class*. Namely for this second class *an opposite position of the poles* follows from the two theories. According to *one of the theories* the position of the poles for the second class should *coincide* with the one of the first class, while for the *other theory* the position of the poles for the second class should be *opposite* compared to the

³⁹[Note by WEW:] Before in the “Resultate aus den Beobachtungen des magnetischen Vereins im Jahre 1839”, [Wilhelm Weber’s *Werke*, Vol. II, p. 171, [Web40]], I tried to justify the conjecture that the phenomenon described by the name “unipolar polarity” could lead to such a decision. However, this is not the case, since there can be given a different explanation for the phenomena described there, as soon as such a connection takes place between the electric fluids moving in the interior of the conductor and the ponderable parts of the conductor, that each force acting on the electric fluids completely or nearly is transferred to the ponderable parts, as I explained in more detail in the “Electrodynamic Measurements” (*Abhandlungen bei Begründung der Königlichen Sächsischen Gesellschaft der Wissenschaften* edited by v. d. F. Jabl. Ges. Art. 19, p. 309), [Wilhelm Weber’s *Werke*, Vol. III, p. 134, [Web46, Section 19] and [Web07, Section 19]].

first class.

As long as one knew just such variable magnets where the position of the poles (for separating forces pointing in the same direction) *coincided*, both theories explained these magnets and only according to the second theory the assumption was necessary that magnets of the second class do not exist at all or are always connected to magnets of the first class in such a way that the effect of the latter one is always dominating. Since the first theory did not require such a hypothesis, it seemed even to be the preferred theory as long as one just knew magnets with the *same* position of the poles for separating forces pointing in the same direction. As soon as variable magnets (diamagnets) were discovered, where the position of the poles (for separating forces pointing in the same direction) was *opposite*, there was no choice anymore between the two theories. In fact only the second theory could be used since only it explains the formation of two classes of magnets with *opposite* position of the poles for separating forces pointing in the same direction.

The *diamagnetic* phenomena discovered by Faraday decide between these two theories in the same way as the phenomena of interference decided between the emission and wave theory in optics. This is the most essential and important meaning associated to this discovery. Thanks to the discovery of diamagnetism the hypothesis of *electric molecular currents in the interior of materials* gets affirmed and the hypothesis of *magnetic fluids in the interior of materials* gets disproved.

All our hypotheses and notions of materials can always just be applied to a limited range of phenomena and they can be distinguished by the size of their range of applications. We associate *reality* to them as long as we do not know any phenomena outside of the range of their application. In the opposite case we denote them as *ideal*. Even if the *magnetic fluids* have to be treated in the future as *ideal* notions, they nevertheless keep the same importance and meaning they had before as long as one applies them to the range where they are valid. And even if we now associate to *the electric molecular currents* in the interior of materials *reality*, same as to the ether in optics responsible for the propagation of waves, it can happen in the future by further development of science that they have to be transferred to the class of *ideal* notions.

23 On the Dependence of the Magnetic and Diamagnetic Moment on the Size of the Separating Force

The exactness of the result that there do not exist magnetic but just electric fluids for which however in ponderable materials two kinds of orbits exist on which they can move, namely those on which their movement is subject to resistance proportional to their velocity and those where there is no resistance at all (molecular currents), according to the previous discussions is mainly due of the opposite *position of the poles* or their opposite *direction*. In virtue of this consideration one distinguishes between magnetic and diamagnetic materials. However, there is another way how to check the correctness of this result if one examines in addition the *strength* of this separation more closely. In fact there is not such a big difference between the two theories in connection with the *strength* of this separation as in connection with the *direction*. The final decision between the two theories requires the development of these differences which occur in both theories in connection with the *strength* of the ideal separation and checking them with experience.

According to the theory of *actually existing magnetic fluids*, the magnetic moments are *proportional* to the separating forces as mentioned in the footnote at the end of Section 21, contradicting experience in view of the experiments by Müller. If on the other hand the theory of *molecular currents* did not lead to such a contradiction with experience, the validity of the latter theory could be shown in this way without reference to the *diamagnetic* phenomena and the *wrong position of the poles* as we did in the previous Sections. However, one has to consider a crucial circumstance which shows that this proof alone just using *magnetic* experiments without reference to the *diamagnetic ones* is not completely decisive. As already discussed in Section 14, under the hypothesis of the *actual existence of magnetic fluids* there are *two ways* how magnets *come into existence*, namely by *separation* of magnetic fluids in molecules *at rest* or through *rotation* of molecules in which the magnetic fluids are separated *permanently*. The already mentioned theory developed by Poisson and Neumann explaining that magnetic moments are *proportional* to the separating forces, is only concerned with the laws to determine the magnetism of magnets originating according to the *first* kind. It has to be examined more closely if the same laws without modification can be applied to the determination of the magnetism of magnets of the *second* kind. This is not the case, but for magnets of the *second* kind other laws hold and in fact *the same ones* as for magnets whose magnetism is due to *rotatable molecular currents*. Hence when the laws of the latter magnets coincide with

experience, it follows immediately that experience has to coincide as well with the laws of magnets, whose magnetism is due to *rotatable molecules with permanently separated magnetic fluids*. Therefore these laws alone cannot lead to a *general* disproof of the actual existence of magnetic fluids, but just to a disproof of the origin of these magnets by *separation* of magnetic fluids, as assumed in the theory developed by Poisson and Neumann.

But even this *partial* disproof gains a larger meaning by considering the reasons which justified Poisson and Neumann to assume a *separation* of magnetic fluids into molecules at rest and *no rotation* of the molecules with permanently separated magnetic fluids. By examining more closely how the hypothesis of the existence of *magnetic* fluids was proposed one sees easily that it mainly originates by its analogy with the *theory of static electricity*. This analogy consists mainly in the fact that if iron gets magnetized, a similar separation of magnetic fluids takes place in the iron molecules as the one of electric fluids when little conductors get electrified. However, this analogy is completely lost, when the magnetization of iron is not due to a *separation* of magnetic fluids in the iron molecules but due to a *rotation* of the iron molecules themselves. It follows from this that the hypothesis of the existence of two magnetic fluids lose their original foundation based on *analogy with the theory of electricity* by disproving the theory of Poisson and Neumann. Instead of that it has to be considered like a completely new hypothesis. This can be seen as well by the fact that in this case even the name of magnetic *fluids* is not suitable anymore. Indeed, when these substances in the iron molecules are *permanently* separated and always fixed in the same way to the iron particles and are only movable *together* with the iron particles, it does not make sense to talk of a *liquid* state of matter. It is even debatable to consider these substances as separated from iron if they are in reality always fixed to the iron particles. Instead of that it were sufficient to distinguish *two kinds of iron particles*.

The mentioned *partial* disproof also gains a deeper significance in that it destroys each *analogy* one tried to establish before between the hypotheses of *magnetic* and *electric* fluids. This analogy gained a certain likelihood by the hypothesis whose actual value is difficult to determine exactly and therefore can be easily rated too high. In view of the above mentioned *disproof of the separation theory* it disappears completely.

In the same ratio a theory, namely the one built on the *actual existence of magnetic fluids*, loses on likelihood, the other one, namely the one built on the *existence of molecular currents*, gains, in particular, if it can be proved that the *strength* of the magnetic moments of different separating forces behaves precisely as predicted by this theory. The theory so far just checked by the observed *direction* of the separation could be checked and confirmed

by observing the *strength* of the separation. It follows from this that this second checking is a crucial supplement and completion of the first one which therefore will be discussed in detail in the following Sections.

24 Connection Between the Existence of a Maximal Value of the Magnetic Moment and the Assumption that the Molecules Are Rotatable

Although the assumption of *rotatable molecular magnets* agrees in the determination of the *location of the poles* with the assumption of *separable magnetic fluids* for nonmovable molecules as explained in Section 16, the two disagree however in an essential way concerning the law saying that the *strength of the magnetism of a bar of iron* varies according to the *size of the magnetic force* acting on the iron as discussed in the previous Section. It is not difficult to understand that according to the *first* assumption there is a *limit* for the strength of the magnetism which cannot be exceeded and which corresponds to the case where the axes of the molecules attained a *parallel position* by rotation. But such a *limit* for the strength of magnetism *does not exist* according to the *second* assumption building the foundation of the theory due to Coulomb, Poisson and Neumann, since then there exists in the molecules an *inexhaustable* amount of separable magnetic fluids in analogy with the theory of electricity.⁴⁰ Even if one wanted to modify this last assumption a bit and assumed that due to the strengthening of the force acting on the iron the *whole* neutral magnetic fluid existing in the molecules gets separated, there still would be a crucial difference between the two assumptions. This difference is that the growth of magnetism for a growing force acting on the iron is subject according to the latter assumption to a quite different law *before* the exhaustion of the neutral magnetic fluid than *after* the exhaustion. Namely until the moment where the last bits of the neutral fluid were separated, the ratio of the strength of the force acting on the iron had to be *constant*. For that reason this ratio is referred to as the *magnetic constant* of iron. However, after this moment this ratio has to decrease

⁴⁰[Note by WEW:] Namely according to this assumption the magnetic state of equilibrium is defined that on the surface of all molecular conductors there is a distribution of the two magnetic fluids acting on all points in the interior in such a way that the effect of the external separating forces gets cancelled. It follows easily from this that if one doubles the external separating forces the amount of the magnetic fluid at the surface of all molecules has to be doubled as well, etc.

rapidly. On the other hand according to the first assumption it follows that this ratio is *always variable* and has to decrease *continuously* from the start to the end according to the same law.

In view of this, one obtains the possibility to decide directly from the *phenomena of iron magnetism* if the magnetization of iron has to be associated *according to the hypothesis of actually existing magnetic fluids* either to a *rotation* of its molecules or the *separation* of the magnetic fluids inside its molecules. In the first case the rotatable molecules can be as well carriers of *molecular currents* as of permanently separated *magnetic fluids*, while in the latter case the existence of magnetic fluids has to be considered as for sure. Indeed, only the *rotation* of molecules but not the *separation* of magnetic fluids in the molecules (due to a given magnetic or electromagnetic separating force) can be a possible substitute for the magnetic fluids due to electric currents.

In view of the above mentioned experiments by Müller one has to consider the *latter* assumption of *separable magnetic fluids* in non-rotatable molecules as disproved. It was only left to check if the *continuous decrease* of the ratio of the strength of the magnetism of iron with respect to the size of the separating force acting on the iron as determined by Müller in his experiments is in agreement with the law derived from a certain *rotatability* of the molecules according to the *first* assumption. It can be left undecided if these molecules are the carriers of separated magnetic fluids or of molecular currents. In the mean time the experiments of Müller were repeated by Buff and Zamminer (*Annalen der Chemie und Pharmacie* of Liebig, Wöhler and Kopp Vol. 75, p. 83).⁴¹ The results found by Müller were not confirmed. Instead of that Buff and Zamminer believe to have proved with their experiments that the ratio of the strength of the magnetism of iron compared to the size of the force acting on the iron is actually *constant* as far as it is possible to check with the means currently at our disposal (here they did not take into account the influence of the force due to coercivity if the iron is not completely soft). This result would only be possible under the assumption of *separable* magnetic fluids in non-rotatable molecules. The assumption of *rotatable molecular magnets* and therefore as well of *rotatable molecular currents* were disproved in this way and the *actual existence of magnetic fluids* would appear to be on a sound foundation.

It therefore seemed to be mainly necessary to repeat the same experiments once more in order to decide the contradiction at hand. Hence in the following Section, I describe the experiments carried out by me and the special equipments which I made to get a safe result. The results by Müller were

⁴¹[Note by AKTA:] [BZ50].

confirmed in this way which is in agreement with some experiments made by Joule, already before Müller, reported in *The Annals of Electricity etc. by W. Sturgeon* Vol. V, p. 472.⁴²

25 Experiments to Prove the Existence of a Maximal Value of the Magnetic Moment

It followed from the experiments carried out by Müller that in case of the same forces acting on iron, the decrease of the ratio between the strength of the iron magnetism and the size of the force acting on iron is smaller for *thin* iron bars than for thick ones. Therefore for the comparison between the experiments carried out by Müller and the ones carried out by Buff and Zamminer it is important to note that the thinnest bar used by Müller had a thickness of only 6 millimeters where the thinnest one used by Buff and Zamminer had a thickness of 9 millimeters. This difference in thickness becomes even more influential since the bar of Müller was 330 millimeters long where the one of Buff and Zamminer only 200 millimeters. I used for the following experiments an even thinner bar than Müller, namely one which had a thickness of 3.6 millimeters, a length of 100.2 millimeters and a weight of 8190 milligrams. It turned out that the magnetism of such a thin bar could be measured with high precision by the displacement at a distance of a little mirror magnetometer. The only difficulty which the use of such a thin bar had was the precise separation of the influences on the magnetometer due to iron magnetism and the ones due to the galvanic current. It is clear that if one uses the same galvanic spiral in order to magnetize thick as well as thin bars as was done by Müller, Buff, and Zamminer, this separation is less precise for thin bars since the effect of the spiral remains the same and therefore is for thin bars comparatively bigger than for thick ones. Therefore for the following experiments a spiral was used which was not wider as needed to put in a thin bar. Even with that I was not satisfied but twisted the end of the spiral wire two times in *opposite direction* around the middle of the spiral in a much bigger circle such that the area enclosed by these two twists coincided with the area enclosed by all twists of the narrow spiral. According to the known laws of electromagnetism it follows from this that the current has no effect on the magnetometer at a distance which can easily be checked and confirmed by experiment. The whole effect observable at the magnetometer is than just due to the magnetism of iron which can be determined by the same acuteness and exactness from the known intensity of terrestrial magnetism

⁴²[Note by AKTA:] [[Jou40](#)].

as the magnetism of hard steel magnets according to *absolute measure*. In the *Intensitas etc.* Gauss has given a precise instruction how this is done by using deflection experiments.⁴³

Moreover, it should be stressed that the spirals used by Müller, Buff, and Zamminer were shorter than the magnetized bars of iron. In Müller's case this difference was small since the iron bars on both ends only protruded 15 millimeters from the spiral. In the case of Buff and Zamminer this difference was much bigger since the ends of the longest and thinnest bars protruded 45 millimeters from the spiral. Moreover, this influence got in addition proportionally increased in the experiments by Buff and Zamminer since the length of the part enclosed in the spiral was only 110 millimeters compared to the 300 millimeters in Müller's case. Probably this circumstance is the main reason for the apparent difference of the results the observers obtained. Obviously the effect of the spiral on the iron is strongest in the middle of the spiral but decreasing at its ends and this decrease is exceptionally large outside the spiral. It follows from this that even if by increasing current intensity the effect in the middle part of the bar approached a limit, such an approach could not be felt at all for the parts outside the spiral. For the following experiments a spiral was used which was considerably longer than the iron bar such that according to the laws developed in Section 18 the force acting on the ends of the bar does not noticeable differ from the one on the middle. Only through such a set-up one can obtain a reliable result.

I content myself with briefly compiling the results obtained in this way in the following Table. I do not describe the experiments in detail, which does not seem necessary since up to the just mentioned differences they almost coincide with the description given by Müller, Buff, and Zamminer. I only mention that each single measurement is based on changing the direction of the current four times. In this way the closest agreement was obtained showing that the coercivity of iron did not affect the accuracy of the results. It would have been easy to consider the influence of the temperature of the bar of iron by keeping it constant with the help of a water current. However it turned out that the influence of moderate changes of the temperature was so small that to take it into account one needed much more accurate measurements requiring new equipments which one could not obtain immediately. It is not necessary to explain here how to express the magnetism of iron using *absolute* measure which was carried out in the Table according to known rules. The intensity of the current was determined with the help of a tangent galvanometer according to *absolute* measure. The correction already mentioned by Müller to obtain higher precision which depends on the ratio

⁴³[Note by AKTA:] See footnote 31 on page 59.

between the length of the needle and the diameter of the galvanic ring was identified precisely and taken into account since this was easy to do. The knowledge of the intensity of the current according to *absolute* measure was further used in order to determine the size of the force acting on the iron according to *absolute* measure through which one expresses *terrestrial magnetism*. This was done using the *number* of windings of the spiral through which the current moved and its *dimensions*. Thanks to this procedure one could compare that force with the known *intensity of the force due to terrestrial magnetism*. In the following Table this force is denoted by X . The iron magnetism M one found was divided by the mass of iron expressed in milligrams $p = 8190$ and the magnetism reduced to unit mass is denoted by m .

No.	X	m
1.	658.9	911.1
2.	1381.5	1424.0
3.	1792.0	1547.9
4.	2151.0	1627.3
5.	2432.8	1680.7
6.	2757.0	1722.7
7.	3090.6	1767.3
8.	3186.0	1787.7
9.	2645.6	1707.9
10.	2232.1	1654.0
11.	1918.7	1584.1
12.	1551.2	1488.9
13.	1133.1	1327.9
14.	670.3	952.0

As one sees, the Table decomposes into two parts, namely one where the size of the force acting on the iron is increasing and one where it is decreasing. In the graphical representation in the Figure 7 one sees that the experiments of the second part which were denoted by no. 8 until no. 14 correspond very well to the experiments of the first part denoted by no. 1 until no. 7.⁴⁴

⁴⁴[Note by AKTA:] Text inside Figure 7: Graphical representation of the dependence of the strength of iron magnetism on the strength of the force acting on the iron.

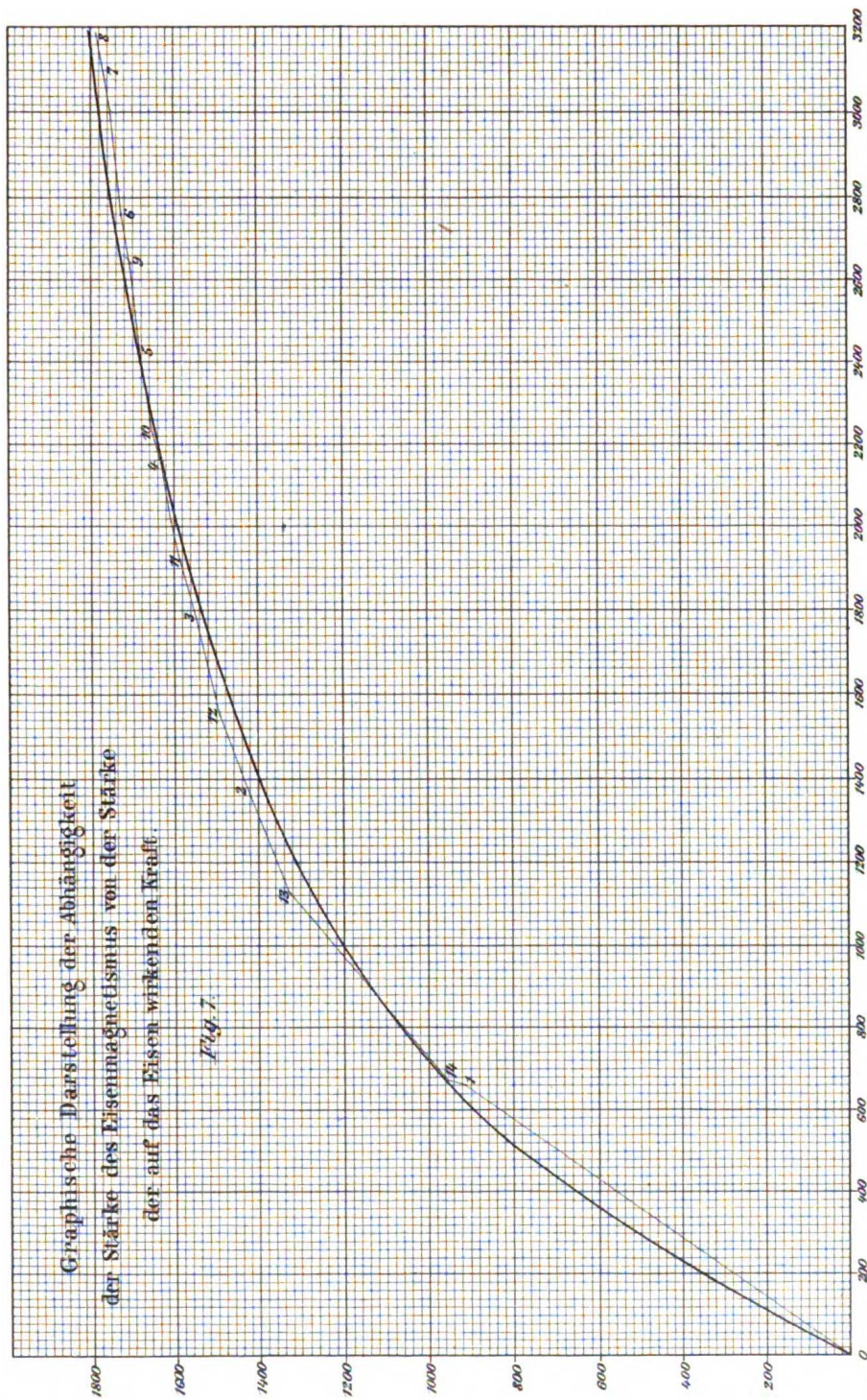

For the last experiment of the first part the iron bar attained a higher temperature and one waited before the start of the following experiments until it cooled down again. Nevertheless one sees that both experiments

fit well with the other ones proving that the influence of the difference in temperature had to be very small.

From these experiments the result seems to follow that the ratio between the strength of the magnetism of iron and the size of the force acting on iron is *variable*. Therefore it is to be expected that the magnetism of iron approaches a *limit* which it can never exceed. Obviously it is impossible to continue with the experiments so far that this limit can be obtained and determined directly by the observations. Such a direct determination of the limit is however not necessary since it suffices that the *continuous variation* of that ratio is proven. The same experiments were repeated by other observers with the same outcome and I believe that there is no doubt on the obtained results. Mainly the result found by Müller is confirmed in this way.

26 The Law of the Dependence of the Magnetic Moment on the Size of the Separating Force According to the Assumption of Rotatable Molecules and Its Comparison with Experiments

It remains to discuss more closely if the variation of the strength of iron magnetism with the size of the forces acting on the iron found by the above experiments coincides with the law deduced from the hypothesis of a certain *rotatability* of the molecules. If this is the case it is clear that one can assume according to Ampère as well that these molecules are the carriers of *molecular currents*. This means that the *emergence* and *transformation* of iron magnetism as well as its *effects* can be explained without the hypothesis of *magnetic fluids* and can be derived merely from the hypothesis of *electric fluids*.

In Figure 8 NS is a molecular magnet rotatable around its midpoint C . ND is the direction to which its magnetic axis is parallel in case of equilibrium when the external force $X = 0$.

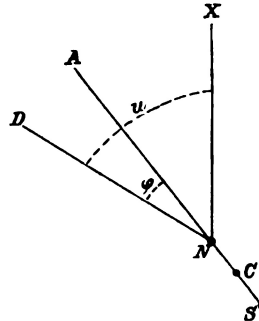

Fig. 8.

The fact that for soft iron the magnetism due to an external force vanishes again as soon as the external force disappears, proves that the molecular magnet whose rotation is responsible for the generated magnetism is driven back in its original position parallel to ND . The repulsive force due to the interaction of the molecules has to increase according to the deflection $AND = \varphi$ and can be expressed by

$$D \sin \varphi ,$$

where D is a constant magnitude referred to as *molecular force of direction*.⁴⁵ In case in addition to the molecular force of direction an external force X is acting whose angle with respect to the direction of the force of direction is $XND = u$, the molecular magnet is rotated or deflected by the angle $AND = \varphi$ and for the determination of the new equilibrium position one has the following equation

$$X \sin u \cos \varphi = (D + X \cos u) \sin \varphi$$

or

$$\tan \varphi = \frac{X \sin u}{D + X \cos u} .$$

From this deflection φ the *increase* of the *magnetic moment* of the molecule decomposed in the direction of the force X can be determined. Namely if one denotes the whole magnetic moment of the molecule by μ then before deflection its component in direction of the force X was

$$= \mu \cos u ,$$

and after deflection

$$= \mu \cos(u - \varphi) ,$$

⁴⁵[Note by AKTA:] *Molekulare Direktionskraft* in the original German language. Alternative translation: molecular directional force.

hence the increase x

$$x = \mu(\cos(u - \varphi) - \cos u) .$$

Substituting in this formula for φ the value obtained from the above equation $\tan \varphi = X \sin u / (D + X \cos u)$ one obtains

$$x = \mu \left\{ \frac{X + D \cos u}{\sqrt{X^2 + D^2 + 2XD \cos u}} - \cos u \right\} .$$

For a system of molecules whose distribution of the axes in the original equilibrium was homogeneous, the number of molecules whose magnetic axis has the angle u with respect to the direction NX of the force X is proportional to $\sin u$. Our task is to determine the magnetic moment y resulting from the rotation of *all* molecules of the system due to the force X .

For this purpose one multiplies the value found above for x by $\sin u du$ and integrates from $u = 0$ until $u = \pi$. This integral value multiplied with the number of molecules n and divided by $\int_0^\pi \sin u du = 2$ gives the *moment* y

$$y = \frac{n}{2} \int_0^\pi x \sin u du .$$

Carrying out the integration one obtains for y the following expression

$$y = n\mu \frac{X}{\sqrt{X^2 + D^2}} \cdot \frac{X^4 + \frac{7}{6}X^2D^2 + \frac{2}{3}D^4}{X^4 + X^2D^2 + D^4} .^{46}$$

The force acting on the iron which caused this moment was $= X$. If one denotes by n the number of molecules *in the volume unit*, then the ratio

⁴⁶[Note by HW:] [This value for y is an approximate value, the actual expression is for $X < D$ given by $y = \frac{2}{3}n\mu \frac{X}{D}$ and for $X > D$ given by $y = n\mu \left(1 - \frac{1}{3} \frac{D^2}{X^2}\right)$.

Wilhelm Weber indicated the change in his Note *Verbesserung einer Formel in den elektrodynamische Maassbestimmungen* which appeared in the *Berichte der Königl. Sächs. Gesellschaft der Wissenschaften zu Leipzig, mathematisch-physische Klasse 1852* where he writes:]

On p. 572, line 22 of the previous article on electrodynamic measurements in the first volume of the *Abhandlungen der mathematisch-physischen Klasse der Königl. Sächs. Gesellschaft der Wissenschaften* was used for y instead of the accurate expression an approximation. I correct this mistake by pointing out that this has no sensible influence on the numerical values deduced from it. In fact the accurate value for y for all values of X , which are smaller than D is $y = \frac{2}{3}n\mu X/D$, and for all values of X which are larger than D one obtains $y = n\mu(1 - \frac{1}{3}D^2/X^2)$.

between the moment y and the force X has in the *rotation theory* the same meaning as the magnitude in the *separation theory* which Neumann denoted by k when he determined the magnetic state of an ellipsoid of revolution in Crelle's *Journal für die reine und angewandte Mathematik*, Vol. 37.⁴⁷ Substituting the variable value y/X for k in Neumann's computation, it follows that, if n is the number of molecules in the volume or mass unit, that the *magnetism reduced to the volume or mass unit* of iron m is given by the following equation

$$m = \frac{y}{1 + 4\pi S \frac{y}{X}} \text{ for the volume unit ,}$$

$$m = \frac{y}{1 + 4\pi S \rho \frac{y}{X}} \text{ for the mass unit .}$$

Here ρ denotes the density of iron and S a factor depending on the form, see Section 21.

After this the strength of iron magnetism m can be computed from the force X acting on the iron if one knows the constants $n\mu$ and D for iron as well as its density ρ for the reduction to the *unit of mass*. Setting

$$n\mu = 2324.68 ,$$

$$D = 276.39 ,$$

one obtains since the density of iron is $\rho = 7.78$ the following comparison between computation and experiment. Here one has to point out however that to determine the factor S instead of the cylindrical shape of iron an approximating ellipsoidal form was substituted giving $S = 1/249$.

⁴⁷[Note by AKTA:] See footnote 37 on page 65.

No.	X	m observed	m computed	difference
1.	658.9	911.1	948.4	-37.3
2.	1381.5	1424.0	1387.0	+37.0
3.	1792.0	1547.9	1533.0	+14.9
4.	2151.0	1627.3	1623.5	+3.8
5.	2432.8	1680.7	1685.0	-4.3
6.	2757.0	1722.7	1742.2	-19.5
7.	3090.6	1767.3	1791.2	-23.9
8.	3186.0	1787.7	1803.4	-15.7
9.	2645.6	1707.9	1723.6	-15.7
10.	2232.1	1654.0	1644.8	+9.2
11.	1918.7	1584.1	1568.9	+15.2
12.	1551.2	1488.9	1452.9	+36.0
13.	1133.1	1327.9	1276.8	+51.1
14.	670.3	952.0	957.5	-5.5

Noting that in these experiments for the measurement of the intensity of the currents one used as tangent galvanometer a usual compass only 60 millimeters long where the fractions of a degree could not be observed with certainty, the intensity could easily be found 1 percent too small or too large. Therefore one could not expect a closer agreement between computation and observation as the one found in the Table. In the graphical representation in Figure 7 the computed values are connected by a *thick* line, the observed ones by a *thin* line. It seems that thanks to this there is no doubt on the *rotatability* of the iron molecules. And since one can consider these iron molecules according to Ampère as the carriers of *molecular currents*, a complete accordance of all magnetic phenomena even the ones observed on *variable* magnets with the theory of *molecular currents* is proved. Through this we found an important confirmation of this theory through *magnetic* phenomena to guarantee the explanation given before for *diamagnetic* phenomena.

27 Application Made to the Comparison in Section 10

In the previous Section we derived the law to determine the strength of iron magnetism in terms of its dependence on the magnetic and electromagnetic separating force using the theory of rotatable molecules. Its most important application concerns the construction of stronger electromagnets, as actually all electromagnetic instruments, whose action depends on the strength of iron

magnetism. Since this application which was stressed by Joule and Müller is not directly related to the topic discussed (diamagnetism), I restrict myself to add just the application of this law on the comparison of the strength of an electrodiamagnet from its *magnetic* and *magnetolectric* effects, since I referred to this in Section 10, page 47.

In fact in Section 10 the *magnetism of bismuth* was compared to the *magnetism of iron* in two ways. *First* by examining the *deflection of the needle of a magnet* and *second* by the *electric currents* in a closed conductor induced by the same movement from both materials. From the two comparisons the strength of the *diamagnetism of bismuth* can be determined according to absolute measure as soon as one knows the strength of the *magnetism of iron* according to absolute measure. Hence one just has to apply the law above to the determination of iron magnetism, in order to obtain *two* independent determinations for the diamagnetism of bismuth, which in view of their agreement confirm *the law of diamagnetic polarity*. Although already in Section 10 under the conditions there the law derived from the experiments of Müller was applied to the determination of iron magnetism, we remarked, that the result found there is not completely sure and exact at all. Therefore it will give us more certainty and exactness, if we apply the more precisely determined law from the previous Section.

According to the first footnote in Section 10, the *diamagnetism* induced in bismuth by an electromagnetic force $X = 629.9$ was compared to the *magnetism* induced in iron by the same force by examining the *torques exerted on a magnetic needle*. Its ratio was found to be

$$1 : 1470000 .$$

Using this ratio, the *diamagnetism* can be determined *according to absolute measure* if one knows the *magnetism of iron according to absolute measure*. According to the previous Section, one has for $X = 629.9$

$$\frac{y}{X} = 3.3959 .$$

If one substitutes as in the previous Section for the cylindrical shape of the little iron bar, which was 92 millimeters long and 0.1016 millimeters thick, a closely approximating form of an ellipsoid, one obtains according to Neumann

$$S = \frac{1}{138780} .$$

Using that value one finds by putting $\rho = 7.78$

$$\log m = \log \frac{yT}{X} - \log \left(1 + 4\pi S\rho \frac{y}{X} \right) = 3.32919 ,$$

hence for *iron magnetism according to absolute measure*

$$m = 2134 .$$

For this value of *iron magnetism* one obtains according to the ratio quoted above for the *diamagnetism of bismuth according to absolute measure* corresponding to the same force $X = 629.9$

$$= \frac{1}{1470000} \cdot 2134 = \frac{1}{689} .$$

Furthermore in footnote 17 in Section 10, the *diamagnetism* produced in bismuth by an electromagnetic force $X = 3012$ was compared to the *magnetism* produced in iron by the same force *by looking at the intensity of the through their motion induced electric currents in a closed conductor*. Their ratio was found to be 1 : 456700 or after the reduction for bismuth stated in Section 10

$$1 : 360740 .$$

With the help of this ratio the *diamagnetism according to absolute measure* can be determined, when one knows the *iron magnetism according to absolute measure*. According to the previous Section for $X = 3012$ one has

$$\frac{y}{X} = 0.77133 .$$

If one substitutes here as well for the cylindrical form of the little iron bar, which was 186 millimeters long and 0.8342 millimeters thick, a closely approximating form of an ellipsoid, one obtains according to Neumann

$$S = \frac{1}{9747} ,$$

and therefore, for $\rho = 7.78$,

$$\log m = \log \frac{yT}{X} - \log \left(1 + 4\pi S \rho \frac{y}{X} \right) = 3.36274 ,$$

hence for *iron magnetism according to absolute measure*

$$m = 2305.4 .$$

For this value of *iron magnetism* one obtains from the above mentioned ratio the *diamagnetism of bismuth according to absolute measure* corresponding to the same force $X = 3012$

$$= \frac{1}{360740} \cdot 2305.4 = \frac{1}{156.5} .$$

Finally, reducing this strength of diamagnetism obtained for different values of the force X by division by X one obtains according to the *first* comparison (by *magnetic* effects) for the *strength of the diamagnetism of bismuth with respect to the unit of force and the unit of mass according to absolute measure* the value

$$\frac{1}{629.9} \cdot \frac{1}{689} = \frac{1}{434000}.$$

On the other hand from the latter comparison (by *electric* effects) one obtains

$$\frac{1}{2301} \cdot \frac{1}{156.5} = \frac{1}{471300}.$$
⁴⁸

Averaging one obtains for the *strength of the diamagnetism of bismuth with respect to the unit of force and the unit of mass according to absolute measure* the value

$$= \frac{1}{452000}.$$

According to the formulas stated in the previous Section, one finds for the *limit of the magnetism produced by iron according to absolute measure with respect to the unit of force and the unit of mass* the value

$$= 5.6074$$

which is 2540000 times bigger as the diamagnetism.

For *small separating forces* and *thin iron bars* for which the magnetism of iron is almost in a *constant* ratio to the diamagnetism of bismuth, it follows that the *diamagnetism of bismuth* is about $2\frac{1}{2}$ *millions* times smaller than the *magnetism of iron*. The larger the separating forces and the thicker the iron bars become, the more the diamagnetism of bismuth is increasing with respect to the magnetism of iron, so that according to the case stated in Section 10, it increased up to the 360740th part of the iron magnetism, which is the largest value occurring in the experiments above.

⁴⁸[Note by WEW:] According to this ratio it follows easily, by assuming the result obtained from the *magnetic* effect of bismuth = $\frac{1}{1470000}$ found at the beginning of Section 10 on page 42, that the result = $\frac{4340}{4713} \cdot \frac{1}{1470000} = \frac{1}{1596000}$ deduced from the *magnetolectric*, has to be put instead of = $\frac{1}{1731560}$, which was found in Section 10 on page 47 based on the experiments by Müller. Incidentally, the more precise result found here has already been mentioned with reference to this Note.

References

- [Ass03] A. K. T. Assis. Tradução de uma obra de Gauss. *Revista Brasileira de Ensino de Física*, 25:226–249, 2003. Paper in Portuguese: “Translation of a work by Gauss”.
- [BZ50] H. Buff and F. G. K. Zamminer. Ueber die Magnetisirung von Eisenstäben durch den galvanischen Strom. *Annalen der Chemie und Pharmacie*, 75:83–94, 1850.
- [Far50] M. Faraday. On the polar or other condition of diamagnetic bodies. *Philosophical Transactions*, 140:171–188, 1850. Reprinted in *Great Books of the Western World*, R. M. Hutchins (editor), (Encyclopaedia Britannica, Chicago, 1952), Vol. 45: Lavoisier, Fourier, Faraday. Pp. 658-669.
- [Fei48] C. Feilitzsch. Eine Theorie des Diamagnetismus. Magnetismus des Wismuth. Erweiterung der Ampère’schen Theorie. *Annalen der Physik und Chemie*, 73:90–110, 1848.
- [Gau32] Gauss. Announcement of “Intensitas Vis Magneticae Terrestris ad Mensuram Absolutam Revocata”. *Göttinger gelehrte Anzeigen*, 205-207:2041–2058, 1832. Reprinted in C. F. Gauss’s *Werke*, Vol. 5, pp. 293-304 (Königlichen Gesellschaft der Wissenschaften (ed.), Göttingen, 1867).
- [Gau33] C. F. Gauss. Die Intensität der erdmagnetischen Kraft, zurückgeführt auf absolutes Maass. *Annalen der Physik und Chemie*, 28:241–273 and 591–615, 1833. Translated by J. C. Poggendorff.
- [Gau34] C. F. Gauss. Mesure absolue de l’Intensité du Magnétisme terrestre. *Annales de Chimie et de Physique*, 57:5–69, 1834.
- [Gau36] C. F. Gauss, 1836. Ob ismërenii zemnago magnitizma. (Soč[inenie] Karl[a] Frid[richa] Gaussa). Per[evël] A. Drašusov. Učenyja zapiski Imperatorskago universiteta čast 11, 1836, Nr. 7 (Januar), str. 3-22; Nr. 8 (Februar), str. 246-271; Nr. 9 (März), str. 341-381.
- [Gau37] C. F. Gauss. Misura assoluta dell’ intensità della forza magnetica terrestre. *Effemeridi astronomiche di Milano*, primo supplemento:3–132, 1837. Tradotta e commentata da P. Frisiani.

- [Gau39] C. F. Gauss. Allgemeine Theorie des Erdmagnetismus. In C. F. Gauss and W. Weber, editors, *Resultate aus den Beobachtungen des magnetischen Vereins im Jahre 1838*, volume III, chapter I, pages 1–57. Weidmannschen Buchhandlung, Leipzig, 1839. Reprinted in Carl Friedrich Gauss *Werke*, Vol. 5, pp. 119-194 (Königlichen Gesellschaft der Wissenschaften (ed.), Göttingen, 1867).
- [Gau41a] C. F. Gauss. General theory of terrestrial magnetism. In R. Taylor, editor, *Scientific Memoirs*, Vol. 2, pages 184–251, London, 1841. Richard and John E. Taylor. Translated by Mrs. Sabine, and revised by Sir John Herschel, Bart.
- [Gau41b] C. F. Gauss. Intensitas vis magneticae terrestri ad mensuram absolutam revocata. *Commentationes Societatis Regiae Scientiarum Goettingensis Recentiores*, 8:3–44, 1841. Delivered before the Society in 15 December 1832. Reprinted in C. F. Gauss's *Werke*, Vol. 5, pp. 79-118 (Königliche Gesellschaft der Wissenschaften (ed.), Göttingen, 1867).
- [Gau94] C. F. Gauss. Die Intensität der erdmagnetischen Kraft auf absolutes Maass zurückgeführt. In E. Dorn, editor, *Ostwald's Klassiker der exakten Wissenschaften, Vol. 53*. Wilhelm Engelmann Verlag, Leipzig, 1894. Translation by A. Kiel, notes by E. Dorn. Ferner in: C. F. Gauss *Werke Supplement* — Bd. 3: Varia: 15 Abhandlungen in deutscher Übersetzung. Mit einer Einleitung, einer Bibliographie und Registern herausgegeben von Karin Reich. Hrsg. von der Akademie der Wissenschaften zu Göttingen, Universitätsverlag Göttingen 2019, S. 533-594.
- [Gau35] C. F. Gauss. The absolute measure of magnetic force. In W. F. Magie, editor, *A Source Book in Physics*, pages 519–524, New York, 1935. McGraw-Hill.
- [Gau52] C. F. Gauss, 1952. Intensivnost semnoj magnitnoj sily, privedennaja k absoljutnoj mere. In: B. M. Janovskij (Hrsg): Karl Fridrich Gauss. Izbrannye trudy po zemnomu magnetizmu. Pervod A. N. Krylova. Moskau 1952, str. 23-75.
- [Gau75] C. F. Gauss. Letter from Gauss to Schumacher, April 29, 1845. In *Carl Friedrich Gauss, Werke, Ergänzungsreihe, Vol. V, Briefwechsel C. F. Gauss — H. C. Schumacher, Part 2*, pages 436–440. Georg Olms Verlag, Hildesheim, 1975.

- [Gau95] C. F. Gauss. The intensity of the earth's magnetic force reduced to absolute measurement. Translated from the German by Susan P. Johnson, edited by L. Hecht. Available at <http://21sci-tech.com/translation.html>, 1995.
- [GT14] K. H. Glassmeier and B. T. Tsurutani. Carl Friedrich Gauss - General Theory of Terrestrial Magnetism - a revised translation of the German text. *History of Geo- and Space Sciences*, 5:11–62, 2014. Doi: 10.5194/hgss-5-11-2014.
- [Jou40] J. P. Joule. On electro-magnetic forces. *The Annals of Electricity, Magnetism, & Chemistry; and Guardian of Experimental Science*, 5:470–472, 1840.
- [Mül51a] J. Müller. *Bericht über die neuesten Fortschritte der Physik*. Friedrich Vieweg und Sohn, Braunschweig, 1851.
- [Mül51b] J. Müller. Ueber den Sättigungspunkt der Elektromagnete. *Annalen der Physik und Chemie*, 82:181–188, 1851.
- [Neu48] J. Neumann. Entwicklung der in elliptischen Coordinaten ausgedrückten reciproken Entfernung zweier Punkte in Reihen, welche nach den Laplace'schen $Y^{(n)}$ fortschreiten; und Anwendung dieser Reihen zur Bestimmung des magnetischen Zustandes eines Rotations-Ellipsoïdes, welches durch vertheilende Kräfte erregt ist. *Crelle's Journal für reine und angewandte Mathematik*, 37:21–50, 1848.
- [Plü52] Plücker. Ueber ein einfaches Mittel, den Diamagnetismus schwingender Körper zu verstärken. *Annalen der Physik und Chemie*, 73:613–618, 1852.
- [Pog48] J. C. Poggendorff. Ueber die diamagnetische Polarität. *Annalen der Physik und Chemie*, 73:475–479, 1848.
- [Rei48] F. Reich. Versuche über die abstossende Wirkung eines Magnetpols auf unmagnetische Körper. *Annalen der Physik und Chemie*, 73:60–65, 1848.
- [Rei49] F. Reich. On the repulsive action of the pole of a magnet upon non-magnetic bodies. *Philosophical Magazine*, 34:127–130, 1849.
- [Rei19] K. Reich, 2019. Die Intensität der erdmagnetischen Kraft: Nr. 15, pp. xxxix-xlii. In C. F. Gauss *Werke Supplement* — Bd. 3: Varia:

15 Abhandlungen in deutscher Übersetzung. Mit einer Einleitung, einer Bibliographie und Registern herausgegeben von Karin Reich. Hrsg. von der Akademie der Wissenschaften zu Göttingen, Universitätsverlag Göttingen 2019, S. 533-594.

- [Web40] W. Weber. Unipolare Induction. In C. F. Gauss and W. Weber, editors, *Resultate aus den Beobachtungen des magnetischen Vereins im Jahre 1839*, volume IV, chapter III, pages 63–90. Weidmannschen Buchhandlung, Leipzig, 1840. Reprint in Wilhelm Weber's *Werke*, Vol. 2, E. Riecke (ed.), (Springer, Berlin, 1892), pp. 153-175, extract with some amendments and modifications by Weber in Wilhelm Weber's *Werke*, Vol. 2, E. Riecke (ed.), (Springer, Berlin, 1892), pp. 176-179.
- [Web46] W. Weber. Elektrodynamische Maassbestimmungen — Über ein allgemeines Grundgesetz der elektrischen Wirkung. *Abhandlungen bei Begründung der Königl. Sächs. Gesellschaft der Wissenschaften am Tage der zweihundertjährigen Geburtstagfeier Leibnizens's herausgegeben von der Fürstl. Jablonowskischen Gesellschaft (Leipzig)*, pages 211–378, 1846. Reprinted in Wilhelm Weber's *Werke*, Vol. 3, H. Weber (ed.), (Springer, Berlin, 1893), pp. 25-214.
- [Web48a] W. Weber. Über die Erregung und Wirkung des Diamagnetismus nach den Gesetzen inducirter Ströme. *Berichte über die Verhandlungen der Königlich Sächsischen Gesellschaft der Wissenschaften zu Leipzig, mathematisch-physische Klasse, Bd. I aus den Jahren 1846 und 1847*, pages 346–358, 1848. Reprinted in Wilhelm Weber's *Werke*, Vol. 3, H. Weber (ed.), (Springer, Berlin, 1893), pp. 255-265.
- [Web48b] W. Weber. Über die Erregung und Wirkung des Diamagnetismus nach den Gesetzen inducirter Ströme. *Annalen der Physik und Chemie*, 73:241–256, 1848. Reprinted in Wilhelm Weber's *Werke*, Vol. 3, H. Weber (ed.), (Springer, Berlin, 1893), pp. 255-268.
- [Web52a] W. Weber. Elektrodynamische Maassbestimmungen insbesondere über Diamagnetismus. *Abhandlungen der Königlich Sächsischen Gesellschaft der Wissenschaften, mathematisch-physische Klasse*, 1:485–577, 1852. Reprinted in Wilhelm Weber's *Werke*, Vol. 3, H. Weber (ed.), (Springer, Berlin, 1893), pp. 473-554.

- [Web52b] W. Weber. Elektrodynamische Maassbestimmungen insbesondere Widerstandsmessungen. *Abhandlungen der Königlich Sächsischen Gesellschaft der Wissenschaften, mathematisch-physische Klasse*, 1:199–381, 1852. Reprinted in Wilhelm Weber's *Werke*, Vol. 3, H. Weber (ed.), (Springer, Berlin, 1893), pp. 301-471.
- [Web52c] W. Weber. On the excitation and action of diamagnetism according to the laws of induced currents. In R. Taylor, editor, *Scientific Memoirs*, Vol. 5, pages 477–488, London, 1852. Taylor and Francis. Translated by W. Francis from Poggendorff's *Annalen*, Jan. 7, 1848. Available at <https://archive.org/details/in.ernet.dli.2015.212784> and <https://www.biodiversitylibrary.org/bibliography/2501#/summary>.
- [Web66] W. Weber. On the excitation and action of diamagnetism according to the laws of induced currents. In R. Taylor, editor, *Scientific Memoirs*, Vol. 5, pages 477–488, New York, 1966. Johnson Reprint Corporation. Translated by W. Francis.
- [Web07] W. Weber, 2007. Determinations of electrodynamic measure: concerning a universal law of electrical action, 21st Century Science & Technology, posted March 2007, translated by S. P. Johnson, edited by L. Hecht and A. K. T. Assis. Available at <http://21scitech.com/translation.html> and www.ifi.unicamp.br/~assis.