

Photonic quantum technologies

Jeremy L. O'Brien^{1*}, Akira Furusawa² and Jelena Vučković³

The first quantum technology that harnesses quantum mechanical effects for its core operation has arrived in the form of commercially available quantum key distribution systems. This technology achieves enhanced security by encoding information in photons such that an eavesdropper in the system can be detected. Anticipated future quantum technologies include large-scale secure networks, enhanced measurement and lithography, and quantum information processors, which promise exponentially greater computational power for particular tasks. Photonics is destined to have a central role in such technologies owing to the high-speed transmission and outstanding low-noise properties of photons. These technologies may use single photons, quantum states of bright laser beams or both, and will undoubtedly apply and drive state-of-the-art developments in photonics.

The theory of quantum mechanics was developed at the beginning of the twentieth century to better explain the spectra of light emitted by atoms. At the time, many people believed that physics was almost completely understood, with only a few remaining anomalies to be 'ironed out'. The full theory of quantum mechanics emerged as a completely unexpected description of nature at a fundamental level. It portrays a world that is fundamentally probabilistic, where a single object can be in two places at once — superposition — and where two objects in remote locations can be instantaneously connected — entanglement. These unusual properties have been observed, and quantum mechanics remains the most successful theory ever developed, in terms of the precision of its predictions. Today, we are learning how to harness these surprising quantum effects to realize profoundly new quantum technologies.

Quantum information science¹ has emerged over the past several decades to address the question of whether we can gain new functionality and power by harnessing quantum mechanical effects through storing, processing and transmitting information encoded in inherently quantum mechanical systems. Fortunately, the answer is yes. Quantum information is both a fundamental science and a progenitor of new technologies, and already several commercial quantum key distribution (QKD) systems are available, offering enhanced security by communicating information encoded in quantum systems². It is anticipated that such systems will be extended to quantum communication networks, providing security based on the laws of quantum mechanics. Perhaps the most profound (and distant) anticipated future technology is the quantum computer, which promises exponentially faster operation for particular tasks¹ such as factorizing, searching databases and simulating important quantum systems. Quantum metrology³ aims to harness quantum effects in the measurement process to achieve the highest precision allowed by nature, and quantum lithography uses quantum states of light to image features smaller than the wavelength of light used⁴.

There are a number of physical systems being investigated for the development of these future technologies¹, but those involving quantum states of light seem likely to play a central part. Light is a logical choice for quantum communication, metrology and lithography, and is a leading approach to quantum information processing (QIP). Photonic quantum technologies have their origin in the fundamental science of quantum optics, which itself has been a testing ground for the ideas of quantum information science. For example, quantum entanglement was tested experimentally using photons generated from atomic cascades in the 1970s and early 1980s^{5,6}. Later, the nonlinear

process of spontaneous parametric down-conversion (SPDC) was shown to be a convenient source of pairs of photons⁷ for such fundamental experiments and for generating quantum states of a bright laser beam — 'squeezed states'⁸. SPDC has been used for many fundamental quantum information tasks, including quantum teleportation^{9,10}. Similarly, the interaction of single photons with single atoms in an optical cavity — cavity quantum electrodynamics (QED) — is a rich field of fundamental science with major applications in photonic quantum technologies¹¹. Although we don't know exactly what form future quantum technologies will take, it seems probable that quantum information will be transmitted in quantum states of light, and that some level of information processing will be performed on these states. It also seems clear that if we are to realize these technologies we will need to constantly exploit the latest developments in the field of conventional photonics.

Secure communication with photons

Transmission at the speed of light and low-noise properties make photons extremely valuable for quantum communication — the transferring of a quantum state from one place to another¹². A quantum bit (or qubit) of information can be encoded in many different degrees of freedom such as polarization, spatial mode and time. Manipulation at the single-photon level is usually straightforward; for example, using birefringent waveplates in the case of polarization encoding (Fig. 1).

This ability to transfer quantum states between remote locations can be used to greatly enhance communication security. Any measurement of a quantum system will disturb it, and we can use this fundamental fact to reliably detect the presence of an eavesdropper. Several commercially available QKD systems operate on this principle². These QKD systems currently rely on attenuated laser pulses rather than single photons — an approach that has been shown to be sufficient for 'point to point' applications². However, attenuation of these weak laser pulses through transmission in fibres or free space currently limits the range of such systems to hundreds of kilometres. The advanced state of our modern communication systems owes much to the erbium-doped fibre amplifier for its ability to amplify optical signals as they propagate over long distances of optical fibre. Unfortunately, amplification of a quantum signal is not so straightforward because measurement of the quantum state of the signal destroys the information (the same disturbance that allows detection of an eavesdropper). A major challenge is to realize a quantum repeater that is able to store quantum information and implement entangling measurements. Ultimately, sophisticated quantum

¹Centre for Quantum Photonics, H. H. Wills Physics Laboratory and the Department of Electrical and Electronic Engineering, University of Bristol, Merchant Venturers Building, Woodland Road, Bristol BS8 1UB, UK. ²Department of Applied Physics and Quantum Phase Electronics Center, School of Engineering, The University of Tokyo, 7-3-1 Hongo, Bunkyo-ku, Tokyo 113-8656, Japan. ³Department of Electrical Engineering and Ginzton Laboratory, Stanford University, Stanford 94305, California, USA. *e-mail: Jeremy.O'Brien@bristol.ac.uk

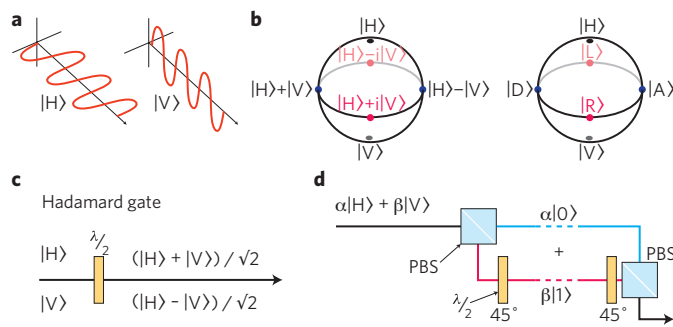

Figure 1 | Encoding and manipulating a qubit in a single photon.

a, A qubit — a quantum ‘bit’ of information — can be encoded using the horizontal ($|H\rangle$) and vertical ($|V\rangle$) polarization of a single photon. **b**, An arbitrary state of a qubit can be represented on the Bloch sphere (known as the Poincaré sphere in optics). Examples of diagonal (D), anti-diagonal (A), right circular (R) and left circular (L) are shown. **c**, A half-waveplate ($\lambda/2$) can be used to rotate the qubit’s polarization. **d**, A polarization-encoded qubit can be interconverted to a path-encoded qubit through a polarizing beamsplitter (PBS).

networks will probably require nodes that have small-scale versions of the quantum information processors described below.

Quantum information processing

The requirements for realizing a quantum computer are conflicting: scalable qubits — two-state quantum systems — must be well isolated from the environment, but they must also be initialized, measured and controllably interacted to implement a universal set of quantum logic gates¹³. Despite this great challenge, many physical implementations are being investigated, including systems based on nuclear magnetic resonance, ions, atoms, cavity quantum electrodynamics, and solid-state and superconducting materials. Over the past few years, single photons have emerged as a leading approach¹⁴.

A major difficulty for optical QIP is the realization of two-qubit-entangling logic gates. The canonical example is the controlled-NOT (CNOT) gate, which flips the state of a target qubit only if the control qubit is in the state ‘1’. This is the quantum analogue of the classical XOR gate. Figure 2a outlines why this operation is difficult for photons. The two optical paths that encode the target qubit are combined at a 50%-reflecting beamsplitter, and the output is then combined at a second beamsplitter to form a Mach–Zehnder interferometer. The logical operation of this interferometer by itself is to leave the photon unchanged, as the classical interference of the single photon in the interferometer results in the target photon exiting with the same state it entered with; that is, $|0\rangle \rightarrow |0\rangle$; $|1\rangle \rightarrow |1\rangle$. If, however, a π phase shift is applied inside the interferometer (such that $|0\rangle + |1\rangle \leftrightarrow |0\rangle - |1\rangle$) the target qubit undergoes a ‘bit-flip’ or NOT operation $|0\rangle \leftrightarrow |1\rangle$. A CNOT gate must therefore implement this phase shift if the control photon is in the ‘1’ path. Unfortunately, however, no known or predicted nonlinear optical material has a nonlinearity strong enough to implement this conditional phase shift, although progress has been made with single atoms in high-finesse optical cavities^{11,15}, and electromagnetically induced transparency has also been considered as a possible scheme¹⁶.

In 2001, a surprising breakthrough showed that scalable quantum computing is possible simply by using single-photon sources and detectors, and linear optical networks¹⁷; that is, an optical nonlinearity is not required. This is known as the KLM scheme after its inventors Knill, Laflamme and Milburn, and it uses additional auxiliary (or ‘ancilla’) photons that are not part of the computation but enable a CNOT gate to function (Fig. 2b). The control and

target qubits, together with two auxiliary photons, enter an optical network of beamsplitters — essentially a multipath nested interferometer — where the paths of the four photons combine and thus allow quantum interference to occur (Fig. 2c). The control and target photons emerge at the output of this network, having had the CNOT logic operation applied to their state, conditional on a single photon being detected at both detectors. This detection event occurs with a probability $P < 1$ — the rest of the time a different detection pattern is recorded and the gate fails. The success probability of this non-deterministic CNOT gate can be boosted to near-unity by harnessing quantum teleportation^{9,18} — a process whereby the unknown state of a qubit can be transferred to another qubit. The idea is to teleport the control and target qubits onto the output of a non-deterministic gate only after the successful detection event has indicated that the gate has succeeded¹⁹.

Although this KLM scheme¹⁷ was possible in principle, the large resource overhead arising from the non-deterministic interactions and the difficulty of controlling photons moving at the speed of light made a practical implementation daunting. This situation has changed over the past several years¹⁴, owing to the experimental proof-of-principle demonstrations of two-^{20–23} and three-qubit gates²⁴, simple-error-correcting codes^{25–27} and small-scale quantum algorithms^{28,29}, as well as theoretical schemes that dramatically reduce the considerable resource overhead^{30–33} by applying the previously abstract ideas of cluster state (or measurement-based) quantum computing³⁴, and their experimental demonstration^{35,36}.

Even with these advances, the resource overhead associated with non-deterministic gates remain high. An alternative approach is to interact photons deterministically through an atom–cavity system^{11,37,38}, which can be configured to implement arbitrary deterministic interactions^{39,40}. There may, however, be a pay-off between the resource overhead and the susceptibility to errors. Irrespective of which approach is chosen, the realization of multiple high-fidelity deterministic single-photon sources remains a major challenge. In the demonstrations described above^{20–29,35,36}, single photons were generated by SPDC: a bright ‘pump’ laser is shone into a nonlinear crystal that is aligned such that a single pump-photon can spontaneously split into two ‘daughter’ photons while conserving momentum and energy. Multiplexing several (waveguide) SPDC sources⁴¹ could provide an ideal photon source. Alternatively, single atom or atom-like emitters such as semiconductor quantum dots could be used, and these show potential for emitting a string of photons pre-entangled in a cluster state⁴², as well as for nodes in quantum networks, discussed below.

Quantum metrology and lithography

All science and technology is founded on measurement, and improvements in precision have led not only to more detailed knowledge but also to new fundamental understanding. The quest to realize increasingly precise measurements raises the question of whether fundamental limits exist. Because measurement is a physical process, one may expect the laws of physics to enforce such limits. This is indeed the case, and it turns out that explicitly quantum mechanical systems are required to reach these limits³.

Interferometers have found application in many fields of science and technology, from cosmology (gravity-wave detection) to nanotechnology (phase-contrast microscopy), because of the subwavelength precision they offer for measuring an optical phase φ (Fig. 2d). However, the phase sensitivity is limited by statistical uncertainty, for finite resources such as energy or number of photons. It has been shown that using semi-classical probes (coherent laser light, for example) limits the sensitivity of $\Delta\varphi$ to the standard quantum limit (SQL) such that $\Delta\varphi \sim 1/\sqrt{N}$, where N is the average number of photons used^{43–45}. The more fundamental Heisenberg limit is attainable with the use of a quantum probe (an entangled

state of photons, for example) such that $\Delta\varphi \sim 1/N$ (refs 3,45) — this is referred to as quantum metrology.

The Heisenberg limit and the SQL can be illustrated with reference to Fig. 2d. Here, we use the quantum state $|10\rangle_{AB}$ to represent a single photon in mode A and no photons in mode B. After the first beamsplitter, this photon is in a quantum mechanical superposition of being in both paths of the interferometer: $(|10\rangle_{CD} + |01\rangle_{CD})/\sqrt{2}$. After the φ phase shift in mode D, this superposition evolves to the state $(|10\rangle_{CD} + e^{i\varphi}|01\rangle_{CD})/\sqrt{2}$. After recombining at the second beamsplitter, the probability of detecting the single photon in mode E is $P_E = (1 - \sin\varphi)/2$ (which is just classical interference at the single-photon level). Determination of P_E can therefore be used to estimate an unknown phase shift φ . If this experiment is repeated N times then the uncertainty in this estimate is $\Delta\varphi \sim 1/\sqrt{N}$ — the SQL — arising from a Poissonian statistical distribution (the same limit is obtained when a bright laser and intensity detectors are used).

If, instead of using photons one at a time, we prepare the maximally entangled N -photon ‘NOON’ state $(|N0\rangle_{CD} + |0N\rangle_{CD})/\sqrt{2}$ in the interferometer, then this state will evolve to $(|N0\rangle_{CD} + e^{iN\varphi}|0N\rangle_{CD})/\sqrt{2}$ after the φ phase shift. From this state we can estimate the phase with an uncertainty of $\Delta\varphi \sim 1/N$ — the Heisenberg limit — which is an improvement of $1/\sqrt{N}$ over the SQL. Beating the SQL is known as phase super-sensitivity^{46,47}. Interference experiments using two-⁴⁸, three-⁴⁶, and four-photon states^{49,50} have been demonstrated, giving rise to a detection probability of $P \propto \sin(N\varphi)$. Observation of such ‘ λ/N ’ fringes, with a period N times shorter than a conventional interferometer for light of wavelength λ , is called phase super-resolution⁴⁶. It has been demonstrated, however, that phase super-resolution can be observed using only semi-classical resources⁴⁷. Observation of λ/N fringes, therefore, does not guarantee quantum-enhanced phase sensitivity, and so precise accounting of resources is required⁵¹.

The closely related idea of quantum lithography involves using quantum states of light, such as the NOON state, to harness the ‘reduced de Broglie wavelength’ to lithographically define $\lambda/2N$ -sized features⁴. Significant challenges include achieving arbitrary two-dimensional patterns and realizing N -photon-sensitive photoresists. For quantum metrology, it is important to consider whether the phase to be measured is fixed (but unknown) or time varying, and therefore requiring a high-bandwidth measurement. A recent breakthrough showed that the requirement of complicated entangled states could be replaced by an increased measurement time⁵², which is useful for the case of a fixed but unknown phase. In contrast, gravity-wave detection involves measurement of a time-varying phase, which can best be addressed by the continuous variable (CV) approaches described below.

Quantum technologies with bright laser beams

The same nonlinear crystal used in SPDC can be used to deterministically create quantum states of a bright laser beam. The variance in the generalized amplitude x and phase p of a light beam are bound by the quantum uncertainty relation $\Delta x \Delta p \geq \hbar/2$. The output of a laser has $\Delta x = \Delta p$, whereas a ‘squeezed’ state of light has $\Delta x \neq \Delta p$. Squeezed states are composed of a beam that is a superposition of only even number of photons and an entangled two-mode squeezed vacuum. Such squeezed states can be used as an alternative to the discrete two-level qubit encoding described above. As with single photons, quantum entanglement for CV photonic quantum technologies can be created in several degrees of freedom of light — the most common is amplitude and phase quadratures⁸, but other methods involve the polarization^{53–55} and spatial modes⁵⁶.

Continuous variable quantum communication can be regarded as the quantum analogue of conventional coherent communication, where information is encoded in coherent states of light (laser light). The essence of CV quantum communication is an ‘optimum

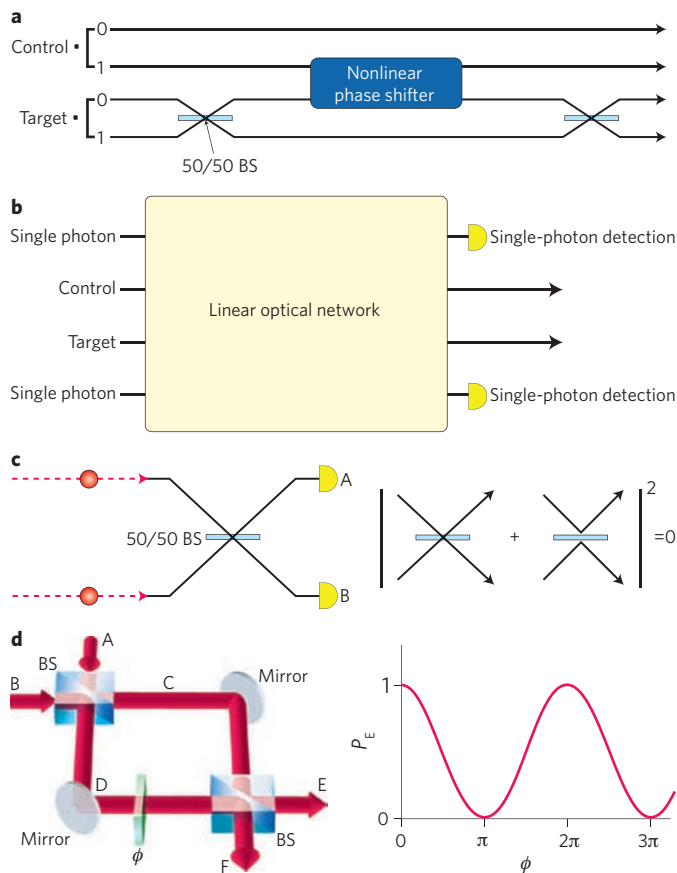

Figure 2 | An optical CNOT gate. **a**, Schematic of a possible realization of an optical CNOT gate, which requires the control photon to induce a π phase shift on the target photon if the control photon is in the ‘1’ state. **b**, Schematic of the KLM scheme to implement a CNOT gate without an optical nonlinearity. The control and target qubits are combined with auxiliary (or ‘ancilla’) photons in a linear optical network consisting of mirrors and beamsplitters. The CNOT operation is then applied to the control and target qubits, conditional on a single photon being detected at each detector. This operation relies on quantum interference at a beamsplitter. **c**, Two photons arriving simultaneously at a beamsplitter (left) both leave in the same output mode with certainty, because the probability amplitudes of detecting a photon at A and B destructively interfere (right). **d**, A Mach-Zehnder interferometer (left). A single photon is incident on the first beamsplitter, after which it is in a superposition of both paths of the interferometer. A phase shift φ is applied, and the probability of the photon leaving in mode E, P_E , is dependent only on this shift (right). The sensitivity with which the phase shift can be measured is related to the gradient of the interference fringe.

measurement’, projecting the encoded states onto some entangled basis states and so allowing a channel capacity with optimum classical (conventional) coding⁵⁷. The realization of this measurement can be regarded as QIP, and thus CV quantum communication and QIP are inseparable. Furthermore, because the processing must include coherent states of light, this measurement is CV QIP. Quantum metrology schemes using adaptive homodyne measurement⁵⁸ have also been demonstrated⁵⁹. This type of ‘quantum feedback and control’ is becoming a powerful tool for quantum metrology.

The most fundamental component of CV photonic quantum technology is CV quantum teleportation^{10,60,61}. The fidelity F of CV teleportation is directly determined by the amount of squeezing r of the quantum entanglement resource, giving $F \leq (1 + e^{-2r})^{-1}$. Squeezing is

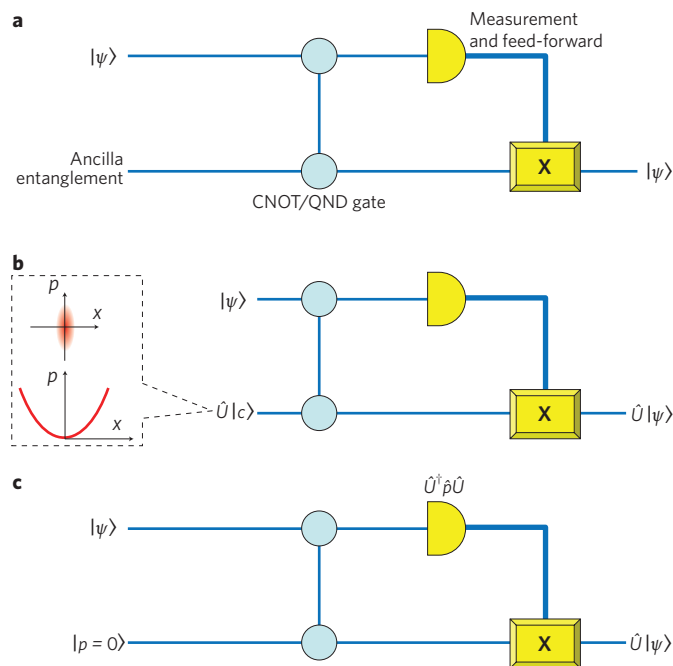

Figure 3 | Generalized teleportation and its applications. **a**, Generalized quantum teleportation. An input $|\psi\rangle$ in the upper mode is ‘teleported’ to the lower mode. Here, the gate functions as either a CNOT gate for qubits or as a quantum non-demolition (QND) gate for CVs. **b**, Off-line quantum information processing with generalized quantum teleportation. The ancilla includes the desired operation \hat{U} and it appears at the output as $\hat{U}|\psi\rangle$. **c**, Generalized quantum teleportation is applied to one-way quantum computation with cluster states. The measurement is generalized as $\hat{U}^\dagger \hat{p} \hat{U}$.

typically quantified by the reduction in noise level of the squeezed variable below the unsqueezed shot noise value, and is measured in decibels. Achieving strong squeezing is experimentally challenging because losses destroy the even-photon nature, and also because an infinite level of squeezing is not physically possible as it would require an infinite amount of energy (that is, an infinite number of photons). In 2006, 7 dB of squeezing was achieved⁶², beating the longstanding record of 6 dB (ref. 63) using periodically poled KTiOPO₄ as the nonlinear medium in a subthreshold optical parametric oscillator cavity. This was increased to 9 dB through an improvement in phase stability in the homodyne measurement⁶⁴. In 2008, 10 dB was achieved with a monolithic MgO:LiNbO₃ optical parametric oscillator⁶⁵, which corresponds to a teleportation fidelity of 0.91. In actual teleportation experiments a fidelity of 0.83 has been achieved⁶⁶, equivalent to 7 dB of effective squeezing.

The advantage of QIP with single-photon qubits is the near-unit fidelity of operations; however, the lack of a strong optical nonlinearity at the single-photon level means that the success events must be selected after the processing (as described above), making this method slow. In contrast, the advantage of QIP with CVs is the deterministic or unconditional nature of processing, but its major disadvantage is the non-unitary fidelity of the processing, owing to the fact that achieving an infinite amount of squeezing is impossible. Hybridization of qubits and CVs for photonic QIP may therefore be desirable for the realization of QIP with unitary fidelity and a high success rate.

Encoding in ‘Schrödinger kittens’

A squeezed vacuum created by SPDC is a superposition of even numbers of photons. When either one or two photons are subtracted from it, the resulting state is a ‘Schrödinger kitten’ — a superposition

of coherent states of opposite phase $|\pm\alpha\rangle_C \equiv |\alpha\rangle \pm |-\alpha\rangle$, where $\alpha \sim 1$ (ref. 67). These ‘kittens’ are almost orthogonal to each other and can therefore be used as logical qubits such that $|0\rangle_L = |-\alpha\rangle_C$; $|1\rangle_L = |+\alpha\rangle_C$. Because the states $|\pm\alpha\rangle_C$ are CV states, this can be regarded as hybrid qubit–CV QIP. These Schrödinger kittens have been demonstrated in the lab^{68–70}.

Squeezing bandwidth is the most important factor for handling these kittens. This is because the avalanche photodiodes typically used for the photon subtraction have a much wider bandwidth than that of the squeezer, and thus the bandwidth of the kittens is the full bandwidth of the squeezer. To handle them, therefore, the bandwidth of QIP must be broader than that of the kittens. More generally, the bandwidth determines the speed of QIP. Because a cavity is typically used to enhance nonlinearities and thus achieve a high level of squeezing, the system bandwidth is limited by the cavity bandwidth, which is usually ~ 100 MHz at most. For broadband quantum teleportation and QIP, therefore, a cavity should not be used — an alternative is to use a waveguide to enhance the nonlinearity, which has been performed with waveguided, periodically poled LiNbO₃ (ref. 71). The bandwidth of squeezing and entanglement in this case is only limited by the bandwidth of the phase-matching condition, which is in principle around 10 THz.

Finally, single photons can be created through single-photon subtraction from a weakly squeezed vacuum, or from so-called photon pairs by removing one of the photons to leave a single remaining photon. Again, to handle single-photon polarization qubits, the bandwidth of QIP should be broader than that of the single photons. Thus, if the bandwidth is broad enough, polarized-photon qubits can be handled in a CV context. This is also the hybridization of qubits and CVs, the first step of which was recently demonstrated through CV teleportation of Schrödinger kittens created using photon subtraction⁷².

Generalized quantum teleportation

The concept of quantum teleportation has been extended to generalized quantum teleportation^{73,74} for both qubit and CV regimes, which can be applied to off-line QIP (where the input mode is not directly processed). Figure 3a shows pre-existing entanglement between the input $|\psi\rangle$ and an ancilla, followed by measurement and feed-forward (that is, a simple operation based on the measurement results). An example is shown in Fig. 3b, in which the ancilla is a specific state $\hat{U}|c\rangle$, where the unitary operation \hat{U} is the one we wish to apply to the input. The crucial advantage of the scheme is that the difficulty of operation is confined to the state preparation of the ancilla, as the fidelity of teleportation itself is rather high. Thus, the unitary operation does not need to be applied and instead it is enough to apply the operator to a particular state $|c\rangle$, which is much easier than for the case of an arbitrary input. There are two important quantum gates that make use of this scheme: a universal squeezer^{75,76} and a cubic phase gate⁷⁷, in which the ancillae are a squeezed state and a cubic phase state, respectively. The universal squeezer⁷⁶ and a quantum non-demolition entangling gate with the squeezers⁷⁸ have been demonstrated. Here, the quantum non-demolition entangling gate is the CV version of a CNOT gate, which is also very important for CV QIP.

Another key application of generalized quantum teleportation is one-way quantum computation with cluster states, both in the qubit and CV regimes^{34,74} (Fig. 4). The essence of the scheme is ‘generalized measurement’, as shown in Fig. 3c. The difference between the schemes in Fig. 3b and Fig. 3c is that the ancilla in Fig. 3c is always in the state $|p=0\rangle$ (an eigenstate of \hat{p} with an eigenvalue of zero). Measurement in Fig. 3c is generalized as $\hat{U}^\dagger \hat{p} \hat{U}$, which corresponds to projection onto eigenstates of the operator $\hat{U}^\dagger \hat{p} \hat{U}$.

The scheme of Fig. 3c can be cascaded, as shown in Fig. 4a. In this case, a special entangled state of many optical beams can be

prepared, and this is referred to as a cluster state (Fig. 4b). By making a measurement on $\hat{U}_i^\dagger \hat{p} \hat{U}_i$ at each mode (optical beam) according to the desired operation and feeding the results forward, the desired output state of $\hat{U}_3 \hat{U}_2 \hat{U}_1 |\psi\rangle$ can be achieved. Measurements on $\hat{U}_i^\dagger \hat{p} \hat{U}_i$ are therefore analogous to software — the desired outputs can be attained simply by changing these measurements. Towards this goal, in 2008 an efficient method of generating multimode CV cluster states was proposed⁷⁹. The CV cluster states shown in Fig. 4 have also been generated experimentally^{80,81}.

Photonics for quantum technologies

Our ability to generate, control and detect light has been driven by — and now permeates — all fields of human activity from communication to medicine. Generating, detecting and manipulating quantum states of light (including single photons and squeezed states) is more challenging than for standard laser beams, but many techniques can nevertheless be adapted from the rich field of photonics. There are two significant challenges for quantum optical circuits. First is that imperfections in the processes used for single-photon generation degrade quantum interference of two or more photons. Second is the fact that optical nonlinearities are generally very small or negligible at the single-photon level, making it difficult to achieve the interaction between two photons (as is required for non-trivial two-qubit gates).

The impressive proof-of-principle demonstrations of photonic quantum technologies described above have mostly relied on large-scale optical elements (such as beamsplitters and mirrors) bolted to room-sized optical tables, with photons propagating through air. In addition, single-photon qubit approaches have relied on unscalable single-photon sources and detectors. For both single-photon qubit and bright CV approaches there is now the need to develop high-performance sources, detectors and optical circuits that are ideally integrated on a single optical chip. For single-photon approaches it is also desirable to realize a strong optical nonlinearity at the single-photon level, whereas for CV approaches an integrated high-bandwidth squeezer is desirable.

These tasks lie at the interface between quantum optics, device fabrication and photonics. In this respect, the mature field of photonics has much to offer the relatively young field of optical quantum technologies. There are already important examples, including photonic quantum circuits on a silicon chip⁸², high-efficiency photon-number-resolving detectors⁸³, semiconductor-cavity-quantum-dot single-photon sources⁸⁴ and photonic crystal quantum-dot-based single-photon nonlinearities⁸⁵. We now take a brief look at recent developments in these areas.

Integrated quantum optical circuits

A promising approach to miniaturizing and scaling optical quantum circuits is to use an on-chip integrated waveguide, which was developed primarily for the telecommunications industry but has been used for stable time-bin interferometers in QKD demonstrations at 1,550 nm (refs 86,87). Such an approach promises to improve performance because spatial mode matching, which is crucial for classical and quantum interference, should be nearly perfect in such an architecture. Recently, silica-on-silicon waveguide quantum circuits were fabricated and used to achieve quantum logic gates with high fidelity⁸² (Fig. 5a,b).

Integration of controlled phase shifters in integrated interferometers has been used to control single-photon qubit states, manipulate multiphoton entangled states of up to four photons and demonstrate on-chip quantum metrology⁸⁸ (Fig. 5c). An integrated quantum optical circuit consisting of several one- and two-qubit gates was recently used to perform a compiled version of Shor's quantum factoring algorithm on a chip⁸⁹.

An alternative fabrication technique based on direct laser writing has been demonstrated⁹⁰. It promises rapid prototyping, fabrication

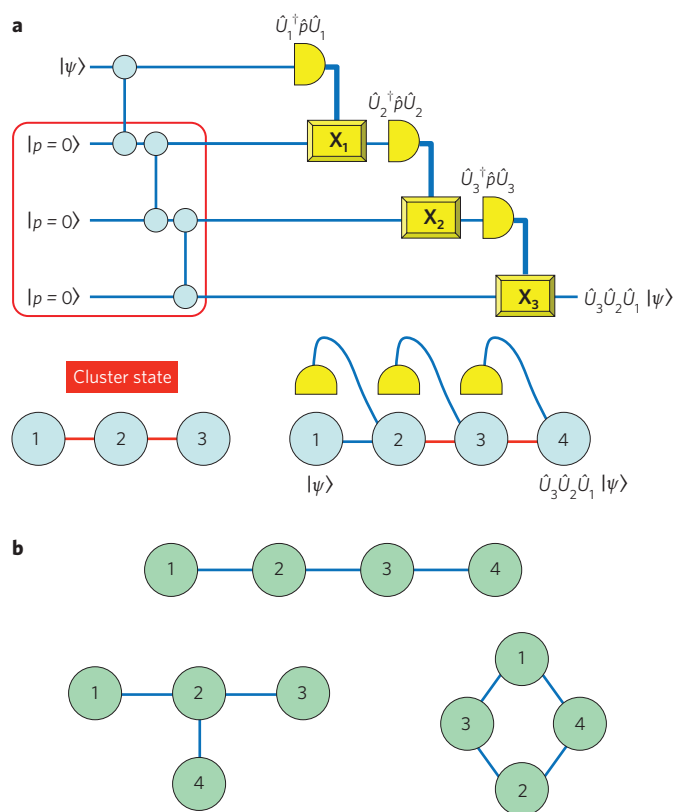

Figure 4 | One-way quantum computation and cluster states. **a**, A three-mode linear cluster state in three cascaded teleportations for the operations \hat{U}_1 , \hat{U}_2 and \hat{U}_3 . **b**, Experimentally created CV cluster states⁸¹. These are simultaneous eigenstates of orthogonal stabilizer generators³⁴.

of high-density three-dimensional devices in material systems that do not lend themselves to conventional lithography, and also provides great control over the transverse spatial mode, which is important for low-loss coupling to sources and detectors. A hybrid fabrication approach using direct writing with UV lasers has also been demonstrated⁹¹. Waveguide squeezers have been used to create entangled beams for CV systems⁷¹. A number of challenges remain to be addressed, including low-loss interfacing with sources, detectors and optical nonlinearities, further miniaturization, fast switching and reconfigurable circuits (through the electro-optical effect, for example).

Detectors

A detailed discussion of photodetectors for quantum technologies is beyond the scope of this review; here we outline some of the key points. Because photodiodes have quantum efficiencies of nearly 100% for visible and near-infrared wavelengths, balanced homodyne detectors with photodiodes are near-ideal quantum detectors for CV systems. It is known, however, that universal quantum computation is impossible using only squeezed states of light, linear optics and homodyne detection⁹². To get the universality of CV QIP (and also of qubit QIP), we need a higher-order nonlinearity that can be obtained through the measurement-induced nonlinearity described above, in which photon counting is essential for both CVs⁷⁷ and qubits. Furthermore, it may be possible to 'synthesize' a powerful nonlinear measurement using quantum feedback and control. One example is the adaptive homodyne measurement described above. It seems clear, therefore, that qubit, CV and hybrid approaches will all require single-photon detectors. Commercially available silicon avalanche photodiodes have an intrinsic quantum

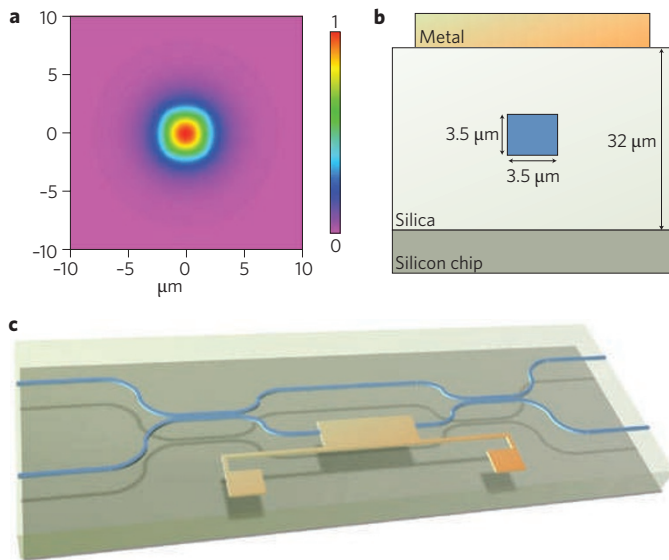

Figure 5 | Silica-on-silicon photonic quantum circuits. **a**, Light is guided in a waveguide much like in an optical fibre, as shown in this simulation of the transverse intensity profile. **b**, Schematic of a silica-on-silicon waveguide structure, showing the core (blue) and silica cladding. The metal heating element is lithographically patterned above the waveguide. **c**, A waveguide Mach-Zehnder interferometer, in which waveguide directional couplers can replace the bulk optics (beamsplitters) of Fig. 2. A metal element functions as a resistive heater that locally changes the refractive index — and thereby the phase — in one waveguide of the interferometer. Figures reproduced with permission from ref. 88, © 2009 NPG.

efficiency of $\sim 70\%$ at 800 nm but, like photomultiplier tubes, are unable to resolve the number of photons in a pulse, which is a key requirement of many QIP applications.

Significant progress has been made in the development of high-efficiency photon-number-resolving detectors⁸³ based on superconducting nanowires, avalanche photodetectors and other technologies, but the development of these detectors still remains a key nanophotonics challenge.

Semiconductor-based single-photon sources

Many quantum technologies, including QKD and photonic-qubit-based quantum computation and networking^{93,94}, require sources of single photons on demand. Ideally, such a source should have a high efficiency (that is, a photon should be emitted and collected in each excitation cycle), a very small probability of emitting more than one photon per pulse (measured by the second-order coherence function), and should produce indistinguishable photons at its output. These three parameters are critical for almost all QIP applications, although some QKD protocols such as BB84 do not require indistinguishable photons.

The basic idea used to generate single photons on demand is very simple: a single quantum emitter (such as a quantum dot, an atom, a molecule, a nitrogen vacancy centre in diamond or an impurity in a semiconductor) is excited with a pulsed source, after which spectral filtering is applied to isolate a single photon with the desired properties at the output⁹⁵. For example, an optical or electrical pulse would generate carriers — electrons and holes — inside a quantum dot; these carriers can occupy only discrete energy levels resulting from quantum confinement and the Coulomb interaction in a quantum dot. When such carriers recombine, they produce several photons of different frequencies, and spectral filtering can be used to isolate a single one.

Although multiphoton probability suppression is already small for a single, isolated quantum emitter excited using the above methods, single-photon efficiency and indistinguishability are poor because photons are emitted in random directions in space, and dephasing mechanisms are strong. However, both efficiency and indistinguishability can be improved by embedding a quantum emitter into a cavity that has a high Q factor and a small mode volume, enhancing the spontaneous emission rate of the emitter relative to its value in bulk (or free space) as a result of its coupling to the cavity mode (known as the Purcell effect). In this case, the external out-coupling efficiency is improved by increasing the fraction of photons coupled to the cavity mode that are redirected towards a particular output where they can be collected. In addition, as a result of the Purcell effect, the radiative lifetime is reduced significantly below the dephasing time, increasing the indistinguishability of emitted photons and the possible repetition rate of the source. This improvement occurs as long as the radiative lifetime is well above the carriers' relaxation time between the higher-order excited states and the first excited state (a 'jitter time' of the order of 10–30 ps in self-assembled InAs/GaAs quantum dots). Through this approach, single photons have been generated with high efficiency and indistinguishabilities of up to 81% by optical⁸⁴ and electrical excitation of quantum dots in micropillar cavities⁹⁶. Such incoherent excitation techniques have a maximum indistinguishability of the order of 90% by using the Purcell effect to tune the radiative lifetime between the jitter and dephasing times. An indistinguishability of 90% was recently reported for a single-photon source based on resonant optical excitation of a single quantum dot weakly coupled to a micropillar cavity⁹⁷. In this case, the jitter time limitation is overcome because carrier relaxation from higher order states is bypassed, but dephasing still affects the performance of the source.

Achieving perfect indistinguishability necessary for quantum computing, however, remains a challenge. To overcome this, cavity quantum electrodynamics (QED) and resonant excitation of the strongly coupled quantum-dot-cavity system could be used⁹⁸. The field of solid-state cavity QED has experienced an exponential growth in recent years, and it is highly likely that we will see solid-state single-photon sources with perfect indistinguishability in the near future.

Strong single-photon nonlinearities on-chip

One of the greatest challenges in photonic QIP is achieving nonlinear interaction between two photons, which is needed for non-trivial two-qubit quantum gates and quantum non-demolition measurements of photon number⁹⁹. This is a result of the fact that optical nonlinearities are very small at the single-photon level. In the past, the largest nonlinearities have been realized using single atoms strongly coupled to resonators^{100,101} and atomic ensembles¹⁰². However, the field of solid-state cavity QED has recently seen rapid progress, including the demonstration of the strong coupling regime in photoluminescence^{103–105} and coherent probing of the strongly coupled quantum-dot-cavity system^{106,107}. It has also recently been shown that the same magnitude of nonlinearity can be achieved in an on-chip configuration with a strongly coupled quantum-dot-nanocavity system¹⁰⁸ — inside a photonic crystal nanocavity containing a strongly coupled quantum dot, one can currently achieve a controlled phase (up to $\pi/4$) and amplitude (up to 50%) modulation between two modes of light at the single-photon level. Finally, photon-induced tunnelling and blockade have also been demonstrated in a solid-state system¹⁰⁹, which makes the solid-state cavity QED systems comparable to their counterparts in atomic physics, in terms of the achievable strength of interaction¹¹⁰.

Solid-state cavity QED systems offer many advantages over atomic cavity QED systems in terms of their scalability, on-chip architecture (Fig. 6), miniaturization, higher speeds resulting from smaller mode volumes, and the fact that quantum emitters do not need

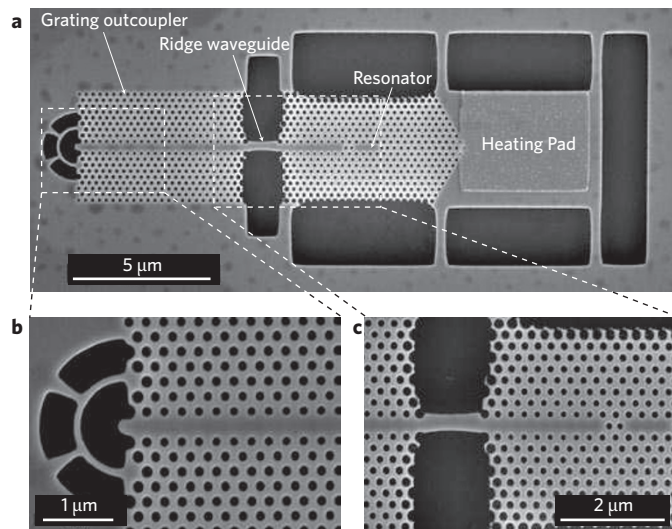

Figure 6 | A basic photonic crystal quantum circuit. **a**, The device consists of a photonic crystal cavity coupled to a photonic crystal waveguide terminated with a grating out-coupler. The cavity contains a single quantum dot, to which it is strongly coupled. For local temperature control, the cavity is placed next to a metal pad that can be heated using an external laser beam. To increase the thermal insulation of the structure, an arrow ridge waveguide link is inserted in the photonic crystal waveguide. **b**, Magnified view of the grating out-coupler. **c**, Magnified view of the ridge waveguide link. Images reproduced with permission from ref. 85, © 2008 OSA.

to be trapped. Despite these advantages, the inhomogeneous broadening of solid-state emitters and their handling at cryogenic temperatures still pose challenges.

Several solutions to these problems have been proposed, such as alignment techniques for photonic crystal resonators to randomly distribute self-assembled quantum dots¹¹¹, the tuning of cavities over the whole chip by digital etching¹¹² or gas condensation¹¹³, local tuning of cavities by photorefractives¹¹⁴ and local tuning of quantum dots by temperature^{115,116} or an electric field^{117,118}. Many groups are also working on nitrogen vacancies in diamond to attain room-temperature operation^{119,120}, but their coupling to photonic structures is challenging and so a strong coupling regime has yet to be achieved.

Researchers are also investigating quantum emitters that are compatible with telecommunications-wavelength operation, but many of these have properties that are inferior when compared with the emitters (quantum dots or nitrogen-vacancy centres) operating at shorter wavelengths. For this reason, frequency conversion techniques at the single-photon level have been proposed and developed in recent years¹²¹, including an on-chip demonstration in a periodically polled lithium niobate waveguide geometry¹²².

On the other hand, atomic systems are also moving towards chip-scale realizations based on, for example, silica microtoroid geometries¹⁵. Photonic approaches not only allow for a more compact realization of QIP proposals, but also enable much smaller cavity mode volumes and higher coupling strengths between the emitters and the cavity field, thus leading to much stronger coupling regimes (and thus higher operating speeds) than previously achievable with larger scale resonators.

Future outlook

We have just witnessed the birth of the first quantum technology based on encoding information in light for QKD. Light seems destined to have a central role in future quantum technologies, including in secure networks and QIP. So far, qubit and CV QIP have largely

been investigated separately — with much progress in each — but many hurdles must be overcome before the ultimate goal of universal QIP can be achieved. Combining these approaches may allow us to take advantage of both regimes, particularly with respect to the power of off-line schemes based on quantum teleportation.

As we have seen, approaches to optical quantum technologies are beginning to adopt state-of-the-art developments from the field of photonics. In the near future we will probably see the development of photonic quantum technologies driving the development of photonics itself. Many challenges also remain in solid-state photonic quantum technologies. As mentioned above, indistinguishable single photons on demand have yet to be demonstrated, but as a result of the recent breakthroughs in solid-state cavity QED we can expect developments in this area in the near future. Furthermore, although controlled phase shifts have been demonstrated between two optical beams at the single-photon level, to reach a full π phase shift we must enhance the cavity QED effects and integrate several of the demonstrated elements. Finally, for these ‘building-blocks’ to be used in functional quantum computers and repeaters, we may also need local quantum memory nodes — it is critical, therefore, to combine the demonstrated efficient photonic building-blocks with techniques for manipulating solid-state qubits.

References

- Nielsen, M. A. & Chuang, I. L. *Quantum Computation and Quantum Information*. (Cambridge Univ. Press, 2000).
- Gisin, N. & Thew, R. Quantum communication. *Nature Photon.* **1**, 165–171 (2007).
- Giovannetti, V., Lloyd, S. & Maccone, L. Quantum-enhanced measurements: Beating the standard quantum limit. *Science* **306**, 1330–1336 (2004).
- Boto, A. N. *et al.* Quantum interferometric optical lithography: Exploiting entanglement to beat the diffraction limit. *Phys. Rev. Lett.* **85**, 2733–2736 (2000).
- Freedman, S. J. & Clauser, J. F. Experimental test of local hidden-variable theories. *Phys. Rev. Lett.* **28**, 938–941 (1972).
- Aspect, A., Grangier, P. & Roger, G. Experimental tests of realistic local theories via Bell’s theorem. *Phys. Rev. Lett.* **47**, 460–463 (1981).
- Kwiat, P. G. *et al.* New high-intensity source of polarization-entangled photon pairs. *Phys. Rev. Lett.* **75**, 4337–4341 (1995).
- Ou, Z. Y., Pereira, S. E., Kimble, H. J. & Peng, K. C. Realization of the Einstein–Podolsky–Rosen paradox for continuous variables. *Phys. Rev. Lett.* **68**, 3663–3666 (1992).
- Bouwmeester, D. *et al.* Experimental quantum teleportation. *Nature* **390**, 575–579 (1997).
- Furusawa, A. *et al.* Unconditional quantum teleportation. *Science* **282**, 706–709 (1998).
- Turchette, Q. A., Hood, C. J., Lange, W., Mabuchi, H. & Kimble, H. J. Measurement of conditional phase shifts for quantum logic. *Phys. Rev. Lett.* **75**, 4710–4713 (1995).
- Gisin, N., Ribordy, G., Tittel, W. & Zbinden, H. Quantum cryptography. *Rev. Mod. Phys.* **74**, 145–195 (2002).
- DiVincenzo, D. P. & Loss, D. Quantum information is physical. *Superlatt. Microstruct.* **23**, 419–432 (1998).
- O’Brien, J. L. Optical quantum computing. *Science* **318**, 1567–1570 (2007).
- Aoki, T. *et al.* Observation of strong coupling between one atom and a monolithic microresonator. *Nature* **443**, 671–674 (2006).
- Schmidt, H. & Imamoglu, A. Giant Kerr nonlinearities obtained by electromagnetically induced transparency. *Opt. Lett.* **21**, 1936–1938 (1996).
- Knill, E., Laflamme, R. & Milburn, G. J. A scheme for efficient quantum computation with linear optics. *Nature* **409**, 46–52 (2001).
- Bennett, C. H. *et al.* Teleporting an unknown quantum state via dual classical and Einstein–Podolsky–Rosen channels. *Phys. Rev. Lett.* **70**, 1895–1899 (1993).
- Gottesman, D. & Chuang, I. L. Demonstrating the viability of universal quantum computation using teleportation and single-qubit operations. *Nature* **402**, 390–393 (1999).
- O’Brien, J. L., Pryde, G. J., White, A. G., Ralph, T. C. & Branning, D. Demonstration of an all-optical quantum controlled-NOT gate. *Nature* **426**, 264–267 (2003).
- O’Brien, J. L. *et al.* Quantum process tomography of a controlled-NOT gate. *Phys. Rev. Lett.* **93**, 080502 (2004).
- Pittman, T. B., Fitch, M. J., Jacobs, B. C. & Franson, J. D. Experimental controlled-NOT logic gate for single photons in the coincidence basis. *Phys. Rev. A* **68**, 032316 (2003).

23. Gasparoni, S., Pan, J.-W., Walther, P., Rudolph, T. & Zeilinger, A. Realization of a photonic controlled-NOT gate sufficient for quantum computation. *Phys. Rev. Lett.* **93**, 020504 (2004).
24. Lanyon, B. P. *et al.* Simplifying quantum logic using higher-dimensional Hilbert spaces. *Nature Phys.* **5**, 134–140 (2009).
25. Pittman, T. B., Jacobs, B. C. & Franson, J. D. Demonstration of quantum error correction using linear optics. *Phys. Rev. A* **71**, 052332 (2005).
26. O'Brien, J. L., Pryde, G. J., White, A. G. & Ralph, T. C. High-fidelity Z-measurement error encoding of optical qubits. *Phys. Rev. A* **71**, 060303 (2005).
27. Lu, C.-Y. *et al.* Experimental quantum coding against qubit loss error. *Proc. Natl Acad. Sci. USA* **105**, 11050–11054 (2008).
28. Lu, C.-Y., Browne, D. E., Yang, T. & Pan, J.-W. Demonstration of a compiled version of Shor's quantum factoring algorithm using photonic qubits. *Phys. Rev. Lett.* **99**, 250504 (2007).
29. Lanyon, B. P. *et al.* Experimental demonstration of a compiled version of Shor's algorithm with quantum entanglement. *Phys. Rev. Lett.* **99**, 250505 (2007).
30. Yoran, N. & Reznik, B. Deterministic linear optics quantum computation with single photon qubits. *Phys. Rev. Lett.* **91**, 037903 (2003).
31. Nielsen, M. A. Optical quantum computation using cluster states. *Phys. Rev. Lett.* **93**, 040503 (2004).
32. Browne, D. E. & Rudolph, T. Resource-efficient linear optical quantum computation. *Phys. Rev. Lett.* **95**, 010501 (2005).
33. Ralph, T. C., Hayes, A. J. F. & Gilchrist, A. Loss-tolerant optical qubits. *Phys. Rev. Lett.* **95**, 100501 (2005).
34. Raussendorf, R. & Briegel, H. J. A one-way quantum computer. *Phys. Rev. Lett.* **86**, 5188–5191 (2001).
35. Walther, P. *et al.* Experimental one-way quantum computing. *Nature* **434**, 169–176 (2005).
36. Prevedel, R. *et al.* High-speed linear optics quantum computing using active feed-forward. *Nature* **445**, 65–69 (2007).
37. Pellizzari, T., Gardiner, S. A., Cirac, J. I. & Zoller, P. Decoherence, continuous observation, and quantum computing: A cavity QED model. *Phys. Rev. Lett.* **75**, 3788–3791 (1995).
38. Duan, L.-M. & Kimble, H. J. Scalable photonic quantum computation through cavity-assisted interactions. *Phys. Rev. Lett.* **92**, 127902 (2004).
39. Devitt, S. J. *et al.* Photonic module: An on-demand resource for photonic entanglement. *Phys. Rev. A* **76**, 052312 (2007).
40. Stephens, A. M. *et al.* Deterministic optical quantum computer using photonic modules. *Phys. Rev. A* **78**, 032318 (2008).
41. Migdall, A. L., Branning, D. & Castelletto, S. Tailoring single-photon and multiphoton probabilities of a single-photon on-demand source. *Phys. Rev. A* **66**, 053805 (2002).
42. Lindner, N. H. & Rudolph, T. Proposal for pulsed on-demand sources of photonic cluster state strings. *Phys. Rev. Lett.* **103**, 113602 (2009).
43. Caves, C. M. Quantum-mechanical noise in an interferometer. *Phys. Rev. D* **23**, 1693–1708 (1981).
44. Yurke, B., McCall, S. L. & Klauder, J. R. SU(2) and SU(1, 1) interferometers. *Phys. Rev. A* **33**, (1986).
45. Giovannetti, V., Lloyd, S. & Maccone, L. Quantum metrology. *Phys. Rev. Lett.* **96**, 010401 (2006).
46. Mitchell, M. W., Lundeen, J. S. & Steinberg, A. M. Super-resolving phase measurements with a multiphoton entangled state. *Nature* **429**, 161–164 (2004).
47. Resch, K. J. *et al.* Timereversal and super-resolving phase measurements. *Phys. Rev. Lett.* **98**, 223601 (2007).
48. Ou, Z. Y., Zou, X. Y., Wang, L. J. & Mandel, L. Experiment on nonclassical fourth-order interference. *Phys. Rev. A* **42**, 2957–2965 (1990).
49. Walther, P. *et al.* De Broglie wavelength of a non-local four-photon state. *Nature* **429**, 158–161 (2004).
50. Nagata, T., Okamoto, R., O'Brien, J. L., Sasaki, K. & Takeuchi, S. Beating the standard quantum limit with four-entangled photons. *Science* **316**, 726–729 (2007).
51. Okamoto, R. *et al.* Beating the standard quantum limit: phase super-sensitivity of N -photon interferometers. *New J. Phys.* **10**, 073033 (2008).
52. Higgins, B. L., Berry, D. W., Bartlett, S. D., Wiseman, H. M. & Pryde, G. J. *Nature* **450**, 393–396 (2007).
53. Bowen, W. P., Treps, N., Schnabel, R. & Lam, P. K. Experimental demonstration of continuous variable polarization entanglement. *Phys. Rev. Lett.* **89**, 253601 (2002).
54. Korolkova, N., Leuchs, G., Loudon, R., Ralph, T. C. & Silberhorn, C. Polarization squeezing and continuous-variable polarization entanglement. *Phys. Rev. A* **65**, 052306 (2002).
55. Laurat, J., Coudreau, T., Keller, G., Treps, N. & Fabre, C. Effects of mode coupling on the generation of quadrature Einstein–Podolsky–Rosen entanglement in a type-II optical parametric oscillator below threshold. *Phys. Rev. A* **71**, 022313 (2005).
56. Wagner, K. *et al.* Entangling the spatial properties of laser beams. *Science* **321**, 541–543 (2008).
57. Sasaki, M., Kato, K., Izutsu, M. & Hirota, O. A demonstration of superadditivity in the classical capacity of a quantum channel. *Phys. Lett. A* **236**, 1–4 (1997).
58. Wiseman, H. M. Adaptive phase measurements of optical modes: Going beyond the marginal Q distribution. *Phys. Rev. Lett.* **75**, 4587–4590 (1995).
59. Armen, M. A., Au, J. K., Stockton, J. K., Doherty, A. C. & Mabuchi, H. Adaptive homodyne measurement of optical phase. *Phys. Rev. Lett.* **89**, 133602 (2002).
60. Vaidman, L. Teleportation of quantum states. *Phys. Rev. A* **49**, 1473–1476 (1994).
61. Braunstein, S. L. & Kimble, H. J. Teleportation of continuous quantum variables. *Phys. Rev. Lett.* **80**, 869–872 (1998).
62. Suzuki, S., Yonezawa, H., Kannari, F., Sasaki, M. & Furusawa, A. 7 dB quadrature squeezing at 860 nm with periodically poled KTiOPO₄. *Appl. Phys. Lett.* **89**, 061116 (2006).
63. Polzik, E. S., Carri, J. & Kimble, H. J. Atomic spectroscopy with squeezed light for sensitivity beyond the vacuum-state limit. *Appl. Phys. B* **55**, 279–290 (1992).
64. Takeno, Y., Yukawa, M., Yonezawa, H. & Furusawa, A. Observation of –9 dB quadrature squeezing with improvement of phase stability in homodyne measurement. *Opt. Express* **15**, 4321–4327 (2007).
65. Vahlbruch, H. *et al.* Observation of squeezed light with 10-dB quantum-noise reduction. *Phys. Rev. Lett.* **100**, 033602 (2008).
66. Yukawa, M., Benichi, H. & Furusawa, A. High-fidelity continuous-variable quantum teleportation toward multistep quantum operations. *Phys. Rev. A* **77**, 022314 (2008).
67. Dakna, M., Anhut, T., Opatrný, T., Knöll, L. & Welsch, D.-G. Generating Schrödinger-cat-like states by means of conditional measurements on a beam splitter. *Phys. Rev. A* **55**, 3184–3194 (1997).
68. Ourjoumstev, A., Tualle-Brouri, R., Laurat, J. & Grangier, P. Generating optical Schrödinger kittens for quantum information processing. *Science* **312**, 83–86 (2006).
69. Neergaard-Nielsen, J. S., Nielsen, B. M., Hettich, C., Mølmer, K. & Polzik, E. S. Generation of a superposition of odd photon number states for quantum information networks. *Phys. Rev. Lett.* **97**, 083604 (2006).
70. Takahashi, H. *et al.* Generation of large-amplitude coherent-state superposition via ancilla-assisted photon subtraction. *Phys. Rev. Lett.* **101**, 233605 (2008).
71. Yoshino, K.-I., Aoki, T. & Furusawa, A. Generation of continuous-wave broadband entangled beams using periodically poled lithium niobate waveguides. *Appl. Phys. Lett.* **90**, 041111 (2007).
72. Lee, N. *et al.* in *CLEO/QEC 2009 Technical Digest CD-ROM paper ITuB4* (CLEO/QEC, 2009).
73. Zhou, X., Leung, D. W. & Chuang, I. L. Methodology for quantum logic gate construction. *Phys. Rev. A* **62**, 052316 (2000).
74. Menicucci, N. C. *et al.* Universal quantum computation with continuous-variable cluster states. *Phys. Rev. Lett.* **97**, 110501 (2006).
75. Filip, R., Marek, P. & Andersen, U. L. Measurement-induced continuous-variable quantum interactions. *Phys. Rev. A* **71**, 042308 (2005).
76. Yoshikawa, J. *et al.* Demonstration of deterministic and high fidelity squeezing of quantum information. *Phys. Rev. A* **76**, 060301(R) (2007).
77. Gottesman, D., Kitaev, A. & Preskill, J. Encoding a qubit in an oscillator. *Phys. Rev. A* **64**, 012310 (2001).
78. Yoshikawa, J.-I. *et al.* Demonstration of a quantum nondemolition sum gate. *Phys. Rev. Lett.* **101**, 250501 (2008).
79. Menicucci, N. C., Flammia, S. T. & Pfister, O. One-way quantum computing in the optical frequency comb. *Phys. Rev. Lett.* **101**, 130501 (2008).
80. Su, X. *et al.* Experimental preparation of quadripartite cluster and Greenberger–Horne–Zeilinger entangled states for continuous variables. *Phys. Rev. Lett.* **98**, 070502 (2007).
81. Yukawa, M., Ukai, R., van Loock, P. & Furusawa, A. Experimental generation of four-mode continuous-variable cluster states. *Phys. Rev. A* **78**, 012301 (2008).
82. Politi, A., Cryan, M. J., Rarity, J. G., Yu, S. & O'Brien, J. L. Silica-on-silicon waveguide quantum circuits. *Science* **320**, 646–649 (2008).
83. Migdal, A. & Dowling, J. (eds) Single-photon detectors, applications, and measurement. *J. Mod. Opt.* (special issue) **51**, (2004).
84. Santori, C., Fattal, D., Vučković, J., Solomon, G. S. & Yamamoto, Y. Indistinguishable photons from a single-photon device. *Nature* **419**, 594–597 (2002).
85. Faraon, A. *et al.* Dipole induced transparency in waveguide coupled photonic crystal cavities. *Opt. Express* **16**, 12154–12162 (2008).
86. Honjo, T., Inoue, K. & Takahashi, H. Differential-phase-shift quantum key distribution experiment with a planar light-wave circuit Mach–Zehnder interferometer. *Opt. Lett.* **29**, 2797–2799 (2004).
87. Takesue, H. & Inoue, K. Generation of 1.5- μm band time-bin entanglement using spontaneous fiber four-wave mixing and planar light-wave circuit interferometers. *Phys. Rev. A* **72**, 041804 (2005).

88. Matthews, J. C. F., Politi, A., Stefanov, A. & O'Brien, J. L. Manipulation of multiphoton entanglement in waveguide quantum circuits. *Nature Photon.* **3**, 346–350 (2009).
89. Politi, A., Matthews, J. C. F. & O'Brien, J. L. Shor's quantum factoring algorithm on a photonic chip. *Science* **325**, 1221 (2009).
90. Marshall, G. D. *et al.* Laser written waveguide photonic quantum circuits. *Opt. Express* **17**, 12546–12554 (2009).
91. Smith, B. J., Kundys, D., Thomas-Peter, N., Smith, P. G. R. & Walmsley, I. A. Phase-controlled integrated photonic quantum circuits. *Opt. Express* **17**, 13516–13525 (2009).
92. Lloyd, S. & Braunstein, S. L. Quantum computation over continuous variables. *Phys. Rev. Lett.* **82**, 1784–1787 (1999).
93. Cirac, J. I., Zoller, P., Kimble, H. J. & Mabuchi, H. Quantum state transfer and entanglement distribution among distant nodes in a quantum network. *Phys. Rev. Lett.* **78**, 3221–3224 (1997).
94. Duan, L.-M., Lukin, M. D., Cirac, J. I. & Zoller, P. Long-distance quantum communication with atomic ensembles and linear optics. *Nature* **414**, 413–418 (2001).
95. Grangier, P., Sanders, B. & Vučković, J. (eds) Focus on single photons on demand. *New J. Phys.* (special issue) **6**, 85–100 (2004).
96. Farrow, T. *et al.* Single-photon emitting diode based on a quantum dot in a micro-pillar. *Nanotechnology* **19**, 345401 (2008).
97. Ates, S. *et al.* Indistinguishable photons from the resonance fluorescence of a single quantum dot in a microcavity. Preprint at <<http://arxiv.org/abs/0902.3612v1>> (2009).
98. Kiraz, A., Atatüre, M. & Imamoglu, A. Quantum-dot single-photon sources: Prospects for applications in linear optics quantum-information processing. *Phys. Rev. A* **69**, 032305 (2004).
99. Noguees, G. *et al.* Seeing a single photon without destroying it. *Nature* **400**, 239–242 (1999).
100. Rauschenbeutel, A. *et al.* Coherent operation of a tunable quantum phase gate in cavity QED. *Phys. Rev. Lett.* **83**, 5166–5169 (1999).
101. Turchette, Q. A., Hood, C. J., Lange, W., Mabuchi, H. & Kimble, H. J. Measurement of conditional phase shifts for quantum logic. *Phys. Rev. Lett.* **75**, 4710–4713 (1995).
102. Braje, D. A., Balić, V., Yin, G. Y. & Harris, S. E. Low-light-level nonlinear optics with slow light. *Phys. Rev. A* **68**, 041801 (2003).
103. Yoshie, T. *et al.* Vacuum Rabi splitting with a single quantum dot in a photonic crystal nanocavity. *Nature* **432**, 200–203 (2004).
104. Hennessy, K. *et al.* Quantum nature of a strongly coupled single quantum dot–cavity system. *Nature* **445**, 896–899 (2007).
105. Press, D. *et al.* Photon antibunching from a single quantum-dot–microcavity system in the strong coupling regime. *Phys. Rev. Lett.* **98**, 117402 (2007).
106. Englund, D. *et al.* Controlling cavity reflectivity with a single quantum dot. *Nature* **450**, 857–861 (2007).
107. Srinivasan, K. & Painter, O. Linear and nonlinear optical spectroscopy of a strongly coupled microdisk–quantum dot system. *Nature Phys.* **4**, 862–865 (2007).
108. Fushman, I. *et al.* Controlled phase shifts with a single quantum dot. *Science* **320**, 769–772 (2008).
109. Faraon, A. *et al.* Coherent generation of non-classical light on a chip via photon-induced tunnelling and blockade. *Nature Phys.* **4**, 859–863 (2008).
110. Birnbaum, K. M. Photon blockade in an optical cavity with one trapped atom. *Nature* **436**, 87–90 (2005).
111. Badolato, A. *et al.* Deterministic coupling of single quantum dots to single nanocavity modes. *Science* **308**, 1158–1161 (2005).
112. Hennessy, K. *et al.* Tuning photonic crystal nanocavity modes by wet chemical digital etching. *Appl. Phys. Lett.* **87**, 021108 (2005).
113. Mosor, S. *et al.* Scanning a photonic crystal slab nanocavity by condensation of xenon. *Appl. Phys. Lett.* **87**, 141105 (2005).
114. Faraon, A. *et al.* Local tuning of photonic crystal cavities using chalcogenide glasses. *Appl. Phys. Lett.* **92**, 043123 (2008).
115. Faraon, A. *et al.* Local quantum dot tuning on photonic crystal chips. *Appl. Phys. Lett.* **90**, 213110 (2007).
116. Faraon, A. & Vučković, J. Local temperature control of photonic crystal devices via micron-scale electrical heaters. *Appl. Phys. Lett.* **95**, 043102 (2009).
117. Laucht, A. *et al.* Electrical control of spontaneous emission and strong coupling for a single quantum dot. *New J. Phys.* **11**, 023034 (2009).
118. Faraon, A., Majumdar, A., Kim, H., Petroff, P. & Vučković, J. Fast electrical control of a quantum dot strongly coupled to a nano-resonator. Preprint available at <<http://arxiv.org/abs/0906.0751>> (2009).
119. Childress, L. *et al.* Coherent dynamics of coupled electron and nuclear spin qubits in diamond. *Science* **314**, 281–285 (2006).
120. Hanson, R., Dobrovitski, V. V., Feiguin, A. E., Gywat, O. & Awschalom, D. D. Coherent dynamics of a single spin interacting with an adjustable spin bath. *Science* **320**, 352–355 (2008).
121. VanDevender, A. P. & Kwiat, P. G. Quantum transduction via frequency upconversion. *J. Opt. Soc. Am. B* **24**, 295–299 (2007).
122. Langrock, C. *et al.* Highly efficient single-photon detection at communication wavelengths by use of upconversion in reverse-proton-exchanged periodically poled LiNbO₃ waveguides. *Opt. Lett.* **30**, 1725–1727 (2005).

Acknowledgements

J.L.O.B. acknowledges support from EPSRC, QIP IRC, IARPA, ERC and the Leverhulme Trust, and also acknowledges a Royal Society Wolfson Merit Award. A.F. acknowledges financial support from SCF, GIA, G-COE, PFN, MEXT, SCOPE and REFOST. J.V. acknowledges support from ONR, ARO and NSF.